

the t.amp

Quadro 500 DSP
power amplifier



Musikhaus Thomann
Thomann GmbH
Hans-Thomann-Straße 1
96138 Burgebrach
Germany
Telephone: +49 (0) 9546 9223-0
E-mail: info@thomann.de
Internet: www.thomann.de

20.05.2021, ID: 438086 (V3)

Table of contents

1	General information	4
	1.1 Further information.....	5
	1.2 Notational conventions.....	6
	1.3 Symbols and signal words.....	6
2	Safety instructions	9
3	Features	12
4	Installation	13
5	Connections and controls	15
6	Operating	19
7	Technical specifications	23
8	Plug and connection assignment	27
9	Cleaning	30
10	Protecting the environment	31

1 General information

This user manual contains important information on the safe operation of the device. Read and follow all safety notes and all instructions. Save this manual for future reference. Make sure that it is available to all persons using this device. If you sell the device to another user, be sure that they also receive this manual.

Our products and user manuals are subject to a process of continuous development. We therefore reserve the right to make changes without notice. Please refer to the latest version of the user manual which is ready for download under www.thomann.de.

1.1 Further information

On our website (www.thomann.de) you will find lots of further information and details on the following points:

Download	This manual is also available as PDF file for you to download.
Keyword search	Use the search function in the electronic version to find the topics of interest for you quickly.
Online guides	Our online guides provide detailed information on technical basics and terms.
Personal consultation	For personal consultation please contact our technical hotline.
Service	If you have any problems with the device the customer service will gladly assist you.

1.2 Notational conventions

This manual uses the following notational conventions:

Letterings

The letterings for connectors and controls are marked by square brackets and italics.

Examples: *[VOLUME]* control, *[Mono]* button.

Displays

Texts and values displayed on the device are marked by quotation marks and italics.

Examples: *'24ch'*, *'OFF'*.

1.3 Symbols and signal words

In this section you will find an overview of the meaning of symbols and signal words that are used in this manual.

Signal word	Meaning
DANGER!	This combination of symbol and signal word indicates an immediate dangerous situation that will result in death or serious injury if it is not avoided.
CAUTION!	This combination of symbol and signal word indicates a possible dangerous situation that can result in minor injury if it is not avoided.
NOTICE!	This combination of symbol and signal word indicates a possible dangerous situation that can result in material and environmental damage if it is not avoided.
Warning signs	Type of danger
	Warning – high-voltage.

Warning signs	Type of danger
	Warning – danger zone.

2 Safety instructions

Intended use

This device amplifies electric audio frequency signals to operate passive speakers. Use the device only as described in this user manual. Any other use or use under other operating conditions is considered to be improper and may result in personal injury or property damage. No liability will be assumed for damages resulting from improper use.

This device may be used only by persons with sufficient physical, sensorial, and intellectual abilities and having corresponding knowledge and experience. Other persons may use this device only if they are supervised or instructed by a person who is responsible for their safety.

Safety



DANGER!

Danger for children

Ensure that plastic bags, packaging, etc. are disposed of properly and are not within reach of babies and young children. Choking hazard! Ensure that children do not detach any small parts (e.g. knobs or the like) from the unit. They could swallow the pieces and choke! Never let children unattended use electrical devices.

**DANGER!****Electric shock caused by high voltages inside**

Within the device there are areas where high voltages may be present. Never remove any covers. There are no user-serviceable parts inside. Do not use the device if covers, protectors or optical components are missing or damaged.

**DANGER!****Electric shock caused by short-circuit**

Always use proper ready-made insulated mains cabling (power cord) with a protective contact plug. Do not modify the mains cable or the plug. Failure to do so could result in electric shock/death or fire. If in doubt, seek advice from a registered electrician.

**CAUTION!****Possible hearing damage**

The device can produce volume levels that may cause temporary or permanent hearing impairment. Over an extended period of time, even levels that seem to be uncritical can cause hearing damage. Decrease the volume level immediately if you experience ringing in your ears or hearing impairment. If this is not possible, keep a greater distance or use sufficient ear protectors.

**NOTICE!****Risk of fire**

Do not block areas of ventilation. Do not install the device near any direct heat source. Keep the device away from naked flames.



NOTICE!

Operating conditions



This device has been designed for indoor use only. To prevent damage, never expose the device to any liquid or moisture. Avoid direct sunlight, heavy dirt, and strong vibrations.



NOTICE!

Power supply



Before connecting the device, ensure that the input voltage (AC outlet) matches the voltage rating of the device and that the AC outlet is protected by a residual current circuit breaker. Failure to do so could result in damage to the device and possibly injure the user. Unplug the device before electrical storms occur and when it is unused for long periods of time to reduce the risk of electric shock or fire.



NOTICE!

Magnetic fields



The device generates strong magnetic fields that can interfere with the function of poorly shielded devices. The strongest magnetic fields are directly above and below the power amplifier. Therefore, never place sensitive devices such as pre-amplifiers, radio transmission systems, or tape decks directly above or below the power amplifier. When installing the power amplifier into a rack, you should place it in the lowest position, and further equipment such as pre-amplifiers in the highest position.



NOTICE!

Possible staining



The plasticiser contained in the rubber feet of this product may possibly react with the coating of your parquet, linoleum, laminate or PVC floor and after some time cause permanent dark stains. In case of doubt, do not put the rubber feet directly on the floor, but use felt-pad floor protectors or a carpet.

3 Features

- 4-channel Class D power amplifier with built-in digital signal processor (DSP)
- Connections for four signal inputs, designed as XLR sockets
- Four lockable output sockets (Speaker Twist)
- Extensive adjustment options allow individual adaptation to different rooms and signal sources
- USB port for connection to a PC
- 19" rack-mountable (1 RU)

4 Installation



NOTICE!

Possible staining

The plasticiser contained in the rubber feet of this product may possibly react with the coating of your parquet, linoleum, laminate or PVC floor and after some time cause permanent dark stains.

In case of doubt, do not put the rubber feet directly on the floor, but use felt-pad floor protectors or a carpet.

Unpack and check carefully there is no transportation damage before using the unit. Keep the equipment packaging. To fully protect the product against vibration, dust and moisture during transportation or storage use the original packaging or your own packaging material suitable for transport or storage, respectively.

Create all connections while the device is off. Use the shortest possible high-quality cables for all connections. Take care when running the cables to prevent tripping hazards.

Rack mounting

The unit has been designed for rack mounting in a standard 19-inch rack; it occupies one rack unit.

5 Connections and controls

Front panel

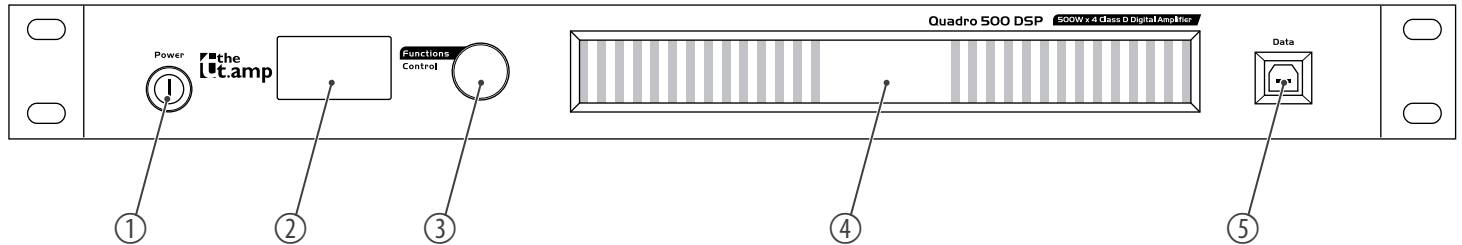

- | | |
|---|---|
| 1 | [POWER]
Main switch. Turns the device on and off |
| 2 | Display |

Quadro 500 DSP

th.mann
MUSIC IS OUR PASSION

3 *[Functions Control]*

Rotary control to open menus, set values, and confirm selections

4 Vents

5 *[Data]*

USB port to connect a computer.

Download the driver "Prolific" from the product website under www.thomann.de to your computer, install it and open the software. Select the device under 'DEVICES'. After 5 seconds, the device is displayed in the right area. Click on 'CONNECT'. The status LED lights green.

Rear panel

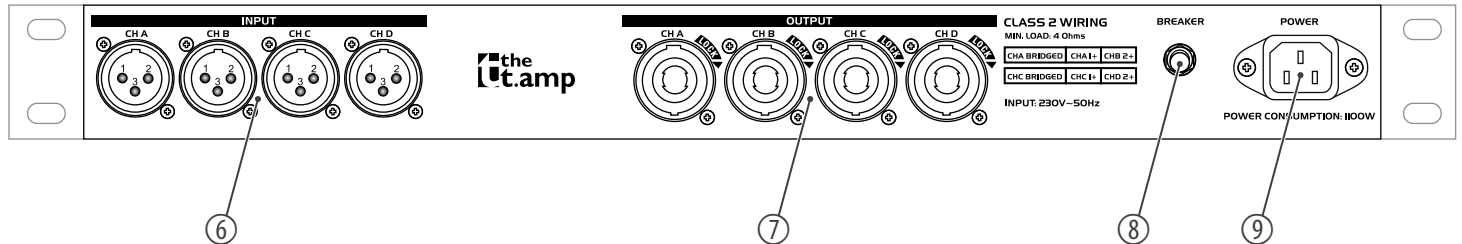

6 [INPUT CH A] ... [INPUT CH D]
Connections for four signal inputs, designed as XLR sockets

7 [OUTPUT CH A] ... [OUTPUT CH D]
Speaker outputs, designed as lockable panel sockets (Speaker Twist)
Normal mode: CH A/B/C/D speaker 1+/1-
'Bridge 12', 'Bridge 34' or 'Bridge 12/34': CH A 1+ and CH A 2+

Quadro 500 DSP

th. mann
MUSIC IS OUR PASSION

8	<i>[Breaker]</i> Resettable fuse
---	-------------------------------------

9	IEC chassis plug for the power supply.
---	--

6 Operating

Level meter and setting

When the main menu is closed, the display symbolically shows the level of the four input channels.

To adjust the volume of the inputs, proceed as follows:

- 1.** ▶ Select with the control [*Functions Control*] one of the channels 'CH1' ... 'CH4' and press the control.
- 2.** ▶ Adjust the level in a range of -70 dB...+10 dB or mute the input ('MUTE').
- 3.** ▶ Press the control.

Main menu

In the main menu, important settings are directly accessible.

1. ▶ Select with the control *[Functions Control]* the option 'MENU' and press the control.
⇒ The main menu opens up.
2. ▶ Use the *[Functions Control]* control to select, to set values, and to navigate the menu. Pressing the control opens a menu item or confirms a setting.
The table below shows an overview of the available menus.
3. ▶ In each submenu, select 'EXIT' to close the submenu.
4. ▶ In the main menu, select 'EXIT' to close the main menu.

Menu item	Meaning
'ROUTING'	Opens the settings for assigning input channels to outputs
'MUTE'	Opens the settings for muting input channels
'DELAY'	Opens the settings for the channel-wise adjustable delay time
'INVERT'	Opens the settings for the inversion of the phase length which can be set per channel

Menu item	Meaning
'EQSETTING'	<p>Opens the settings for the channel-wise switchable 8-band equalizer, the low-pass filter and the high-pass filter.</p> <p>For each of the eight bands, the frequency ('FREQ'), the Q-shape ('Q'), and the level boost / cut ('Gain') can be set. Using the Bypass option ('BP'), the equalizer for the respective frequency can also be switched off completely.</p> <p>For each channel, the option 'LP' can be used to turn on a low-pass filter whose filter type and cut-off frequency can be adjusted. Using the Bypass option ('BPSS'), the low-pass filter for the respective input can also be switched off completely.</p> <p>For each channel, the option 'HP' can be used to turn on a high-pass filter whose filter type and cut-off frequency can be adjusted. Using the Bypass option ('BPSS'), the high-pass filter for the respective input can also be switched off completely.</p> <p>The option 'ALLBYPASS' makes it possible to completely switch off the entire tone control for the respective input channel.</p>
'COMP'	<p>Opens the settings for the channel-wise switchable compressor: Threshold ('THRES'), attack time ('ATTACK'), release time ('RELEASE').</p> <p>The option 'BYPASS' makes it possible to completely switch off the compressor for the respective input channel.</p>
'PRESET'	Allows to load and save presets and resetting to factory defaults
'NOISEGATE'	Opens the settings for the channel-wise switchable noise gate

Menu item	Meaning	
'SYSTEM'	Opens the menu for important basic settings	
'WORKMODE'	'parallel'	Normal mode (connection 1+/1-)
	'bridged'	3 modes selectable: 'Bridge 12', 'Bridge 34' or 'Bridge 12/34' (connection 1+/2+)
	'linked'	Channel A adopt the settings (Gains, EQs, Dynamics) of the channels B, C, and D. Routing stays freely selectable.
'PIN'	PIN selection and key lock activation.	
'TEMP'	Setting the temperature used for the conversion of delay time into distance.	
'NAME'	Naming the device with a string. When the main menu is closed, this string is shown in the display.	
'FIRMWARE'	Display of the firmware version used in the device.	

7 Technical specifications

Amplifier class	D	
Inputs	Signal input	4 × XLR socket
Outputs	Speaker output	4 × lockable input socket (Speaker Twist)
Input impedance	20 k Ω (balanced) 10 k Ω (unbalanced)	
Output power	8 Ω	4 × 250 W
	4 Ω	4 × 500 W
Max. output power 'bridged'	1000 W	
Frequency response	20 Hz ... 20 kHz (0 /– 1 dB)	
Signal-to-noise ratio	95 dB (A-weighted)	
Total harmonic distortion (THD)	< 0.15 %	
Damping factor (1 kHz, 8 Ω)	> 180	

Technical specifications

Sensibility (limiter off)	0.9 V...1.1 V (0 /- 1 dBv)	
Gain	34 dB \pm 0.5 dB	
Crosstalk below rated power	> 50 dB	
Latency	0.66 ms	
Power consumption	1100 W	
Supply voltage	230 V ~ 50 Hz	
Dimensions (W x H x D)	483 mm x 460 mm x 44 mm	
Weight	8.0 kg	
Ambient conditions	Temperature range	0 °C...40 °C
	Relative humidity	20 %...80 % (non-condensing)

Block diagram

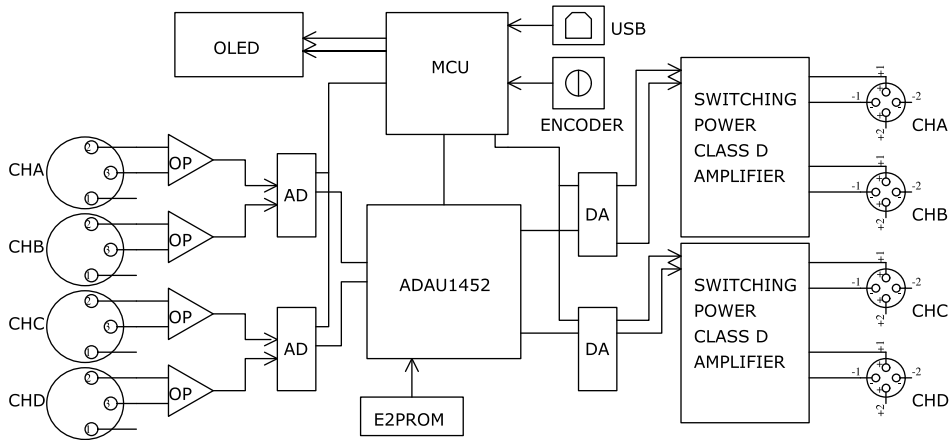

Further information

Power 4Ω/channel	500 W
Channels	4
19" installation height	1 RU
2 Ω stable	No
DSP / crossover	Yes
Convection cooling	No

8 Plug and connection assignment

Introduction

This chapter will help you select the right cables and plugs to connect your valuable equipment in such a way that a perfect sound experience is ensured.

Please note these advices, because especially in 'Sound & Light' caution is indicated: Even if a plug fits into the socket, an incorrect connection may result in a destroyed power amp, a short circuit or 'just' in poor transmission quality!

Balanced and unbalanced transmission

Unbalanced transmission is mainly used in semi-professional environment and in hifi use. Instrument cables with two conductors (one core plus shielding) are typical representatives of the unbalanced transmission. One conductor is ground and shielding while the signal is transmitted through the core.

Unbalanced transmission is susceptible to electromagnetic interference, especially at low levels, such as microphone signals and when using long cables.

In a professional environment, therefore, the balanced transmission is preferred, because this enables an undisturbed transmission of signals over long distances. In addition to the conductors 'Ground' and 'Signal', in a balanced transmission a second core is added. This also transfers the signal, but phase-shifted by 180°.

Since the interference affects both cores equally, by subtracting the phase-shifted signals, the interfering signal is completely neutralized. The result is a pure signal without any noise interference.

XLR plug (balanced)

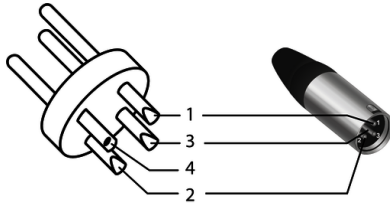

1	Ground, shielding
2	Signal (in phase, +)
3	Signal (out of phase, -)
4	Shielding on plug housing (option)

Speaker Twist connector

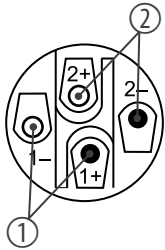

1, +	Signal 1 (positive)
1, -	Signal 1 (negative)
2, +	Signal 2 (positive)
2, -	Signal 2 (negative)

9 Cleaning

Fan grids

The fan grids of the device must be cleaned of any contamination, such as dust, etc. on a regular basis. Before cleaning, switch off the device and disconnect mains-operated devices from the mains. Only use pH-neutral, solvent-free and non-abrasive cleaning agents. Clean the unit with a slightly damp lint-free cloth.

10 Protecting the environment

Disposal of the packaging material



For the transport and protective packaging, environmentally friendly materials have been chosen that can be supplied to normal recycling.

Ensure that plastic bags, packaging, etc. are properly disposed of.

Do not just dispose of these materials with your normal household waste, but make sure that they are collected for recycling. Please follow the notes and markings on the packaging.

Disposal of your old device



This product is subject to the European Waste Electrical and Electronic Equipment Directive (WEEE) in its currently valid version. Do not dispose with your normal household waste.

Dispose of this device through an approved waste disposal firm or through your local waste facility. When discarding the device, comply with the rules and regulations that apply in your country. If in doubt, consult your local waste disposal facility.

Quadro 500 DSP



Musikhaus Thomann · Hans-Thomann-Straße 1 · 96138 Burgebrach · Germany · www.thomann.de