



HZ-1500
Pro Touring Hazer DMX
hazer

Musikhaus Thomann
Thomann GmbH
Hans-Thomann-Straße 1
96138 Burgebrach
Germany
Telephone: +49 (0) 9546 9223-0
E-mail: info@thomann.de
Internet: www.thomann.de

23.08.2019, ID: 450663

Table of contents

1	General notes	5
	1.1 Further information.....	6
	1.2 Notational conventions.....	7
	1.3 Symbols and signal words.....	8
2	Safety instructions	11
3	Features	19
4	Installation	20
5	Starting up	21
6	Connections and controls	23
7	Operating	28
8	Technical specifications	37
9	Plug and connection assignment	38
10	Troubleshooting	40
11	Cleaning	43

12 Protecting the environment..... 45

1 General notes

This manual contains important instructions for the safe operation of the unit. Read and follow the safety instructions and all other instructions. Keep the manual for future reference. Make sure that it is available to all those using the device. If you sell the unit please make sure that the buyer also receives this manual.

Our products are subject to a process of continuous development. Thus, they are subject to change.

1.1 Further information

On our website (www.thomann.de) you will find lots of further information and details on the following points:

Download	This manual is also available as PDF file for you to download.
Keyword search	Use the search function in the electronic version to find the topics of interest for you quickly.
Online guides	Our online guides provide detailed information on technical basics and terms.
Personal consultation	For personal consultation please contact our technical hotline.
Service	If you have any problems with the device the customer service will gladly assist you.

1.2 Notational conventions

This manual uses the following notational conventions:

Letterings

The letterings for connectors and controls are marked by square brackets and italics.

Examples: *[VOLUME]* control, *[Mono]* button.

Displays

Texts and values displayed on the device are marked by quotation marks and italics.

Examples: *'24ch'*, *'OFF'*.

Instructions

The individual steps of an instruction are numbered consecutively. The result of a step is indented and highlighted by an arrow.





Example:

1. ▶ Switch on the device.
2. ▶ Press *[Auto]*.
 - ⇒ Automatic operation is started.
3. ▶ Switch off the device.

1.3 Symbols and signal words

In this section you will find an overview of the meaning of symbols and signal words that are used in this manual.

Signal word	Meaning
DANGER!	This combination of symbol and signal word indicates an immediate dangerous situation that will result in death or serious injury if it is not avoided.
WARNING!	This combination of symbol and signal word indicates a possible dangerous situation that can result in death or serious injury if it is not avoided.
CAUTION!	This combination of symbol and signal word indicates a possible dangerous situation that can result in minor injury if it is not avoided.
NOTICE!	This combination of symbol and signal word indicates a possible dangerous situation that can result in material and environmental damage if it is not avoided.
Warning signs	Type of danger
	Warning – high-voltage.

Warning signs	Type of danger
	Warning – flammable substances.
	Warning - slip hazard.
	Warning – harmful or irritating substances.
	Warning – danger zone.

2 Safety instructions

Intended use

This device is intended to be used to produce fine haze by vaporising hazer fluid. Use the device only as described in this user manual. Any other use or use under other operating conditions is considered to be improper and may result in personal injury or property damage. No liability will be assumed for damages resulting from improper use.

This device may be used only by persons with sufficient physical, sensorial, and intellectual abilities and having corresponding knowledge and experience. Other persons may use this device only if they are supervised or instructed by a person who is responsible for their safety.

Safety



DANGER!

Danger for children

Ensure that plastic bags, packaging, etc. are disposed of properly and are not within reach of babies and young children. Choking hazard!

Ensure that children do not detach any small parts (e.g. knobs or the like) from the unit. They could swallow the pieces and choke!

Never let children unattended use electrical devices.



DANGER!

Electric shock caused by high voltages inside

Within the device there are areas where high voltages may be present. Never remove any covers.

There are no user-serviceable parts inside.

Do not use the device if covers, protectors or optical components are missing or damaged.



DANGER!

Electric shock caused by short-circuit

Always use proper ready-made insulated mains cabling (power cord) with a protective contact plug. Do not modify the mains cable or the plug. Failure to do so could result in electric shock/death or fire. If in doubt, seek advice from a registered electrician.



WARNING!

Risk of burns from flammable liquids

The use of flammable liquids in this appliance can cause serious burns and property damages.

Use only approved hazer fluids. Never fill flammable liquids into the container of the device.



WARNING!

Risk of slipping caused by condensate

Hazer can produce condensate. Do not point the haze on floors. Floors and surfaces can become slippery by condensed haze.

Check regularly that all floors can be accessed without slipping hazard and remove any condensate, if necessary.



WARNING!

Health hazard when handling hazer fluid

Hazer fluid contains glycols, which meet the requirements for food products. Nevertheless, fluid is harmful if swallowed.

Do not induce vomiting. Get immediate medical attention. Keep hazer fluid in a safe place. Rinse the eyes upon contact with hazer fluid thoroughly with water.



CAUTION!

Possible respiratory problems

The device can only be operated safely when using approved hazer fluids. Using other fluids can generate toxic gases. Any claims for compensation for damages caused by using non-approved fluids are excluded.

Do not let the device produce haze in poorly ventilated areas.

Do not expose people with health problems (such as allergy-related respiratory symptoms, asthma) to artificial haze.



NOTICE!

Risk of fire

Do not block areas of ventilation. Do not install the device near any direct heat source. Keep the device away from naked flames.



NOTICE!

Operating conditions

This device has been designed for indoor use only. To prevent damage, never expose the device to any liquid or moisture. Avoid direct sunlight, heavy dirt, and strong vibrations.



NOTICE!

Power supply

Before connecting the device, ensure that the input voltage (AC outlet) matches the voltage rating of the device and that the AC outlet is protected by a residual current circuit breaker. Failure to do so could result in damage to the device and possibly injure the user.

Unplug the device before electrical storms occur and when it is unused for long periods of time to reduce the risk of electric shock or fire.



NOTICE!

Suitable hazer fluid

The device must only be operated with Stairville PHF Fluid (item # 260572).

General information about how to safely operate fog machines and hazers

The device was designed for use in professional event technology and works reliably when used properly. Observe the following information:

- Follow all warnings in these operating instructions.
- Never leave the device running without supervision.
- The device is not suitable for use in private households or as a child's toy.
- Place the device on a stable, fire-proof basis that is at least twice as large as the device.
- Maintain a safety distance of 1 m to flammable materials.
- The device is not intended for suspended assembly (the so-called "flying operation").
- During operation, ensure that the visibility in the room does not fall below 2 m so that everyone in the room can still orient themselves safely.
- The haze or mist generated by the device may trigger smoke alarms.

3 Features

This hazer is suitable to be used in clubs, bars, discotheques and on stages.

Special features of the device:

- Control via DMX-512 and via buttons and display on the unit
- Fast heating-up
- Continuous haze output without reheating up to 50 % output
- Precise regulation of the haze emission
- Compact design
- Specifically designed for touring use
- Fixed in a sturdy flight case
- 3 l liquid container for hazer fluid (Stairville PHF Fluid, item # 260572)

4 Installation

Unpack and check carefully there is no transportation damage before using the unit. Keep the equipment packaging. To fully protect the product against vibration, dust and moisture during transportation or storage use the original packaging or your own packaging material suitable for transport or storage, respectively.

The device requires 20 cm clearance at the sides and above. Place the unit on a flat, stable surface. The device must never be operated in a more than 15° tilted position.

The device is delivered mounted in a sturdy flight case. Do not remove the device from the flight case, there are no serviceable parts inside. Always look for a specialist repair shop for repairs.

Make sure that the ventilation opening of the flight case and the haze nozzle are never covered during operation.

5 Starting up

Create all connections while the device is off. Use the shortest possible high-quality cables for all connections. Take care when running the cables to prevent tripping hazards.

Make sure that the hose for the hazer fluid is firmly connected to the device and to the fluid container.

Connections in DMX mode

Connect the DMX input of the device to the DMX output of a DMX controller or another DMX device. Connect the output of the first DMX device to the input of the second one, and so on to form a daisy chain. Always ensure that the output of the last DMX device in the daisy chain is terminated with a resistor ($110\ \Omega$, $\frac{1}{4}\text{ W}$).

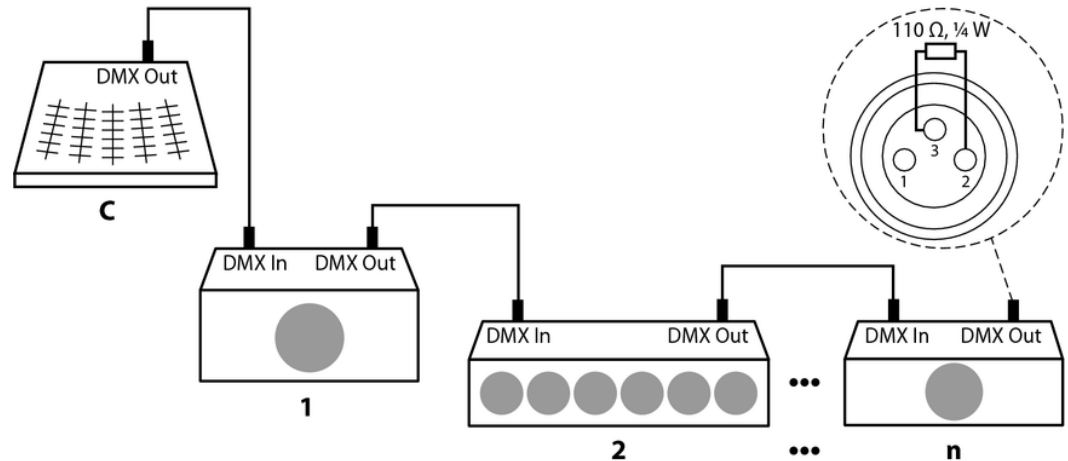

6 Connections and controls

Flight case

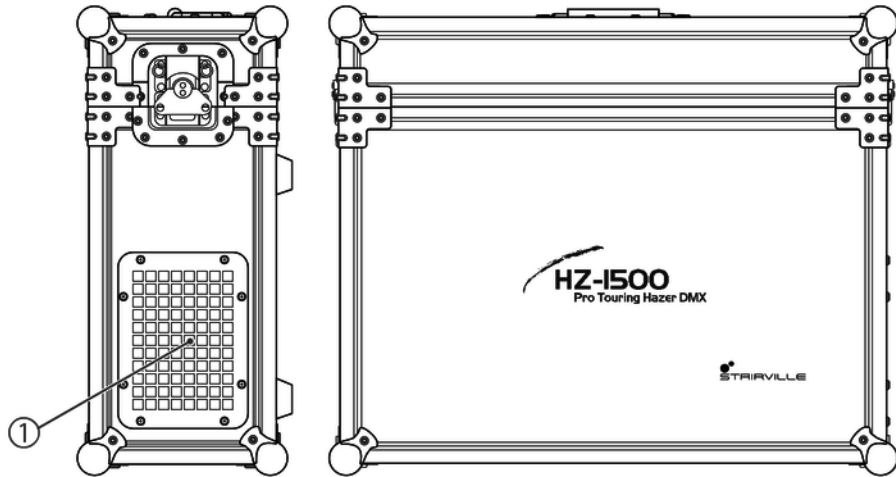

1 Ventilation opening

HZ-1500 Pro Touring Hazer DMX

th.mann
MUSIC IS OUR PASSION

Control panel

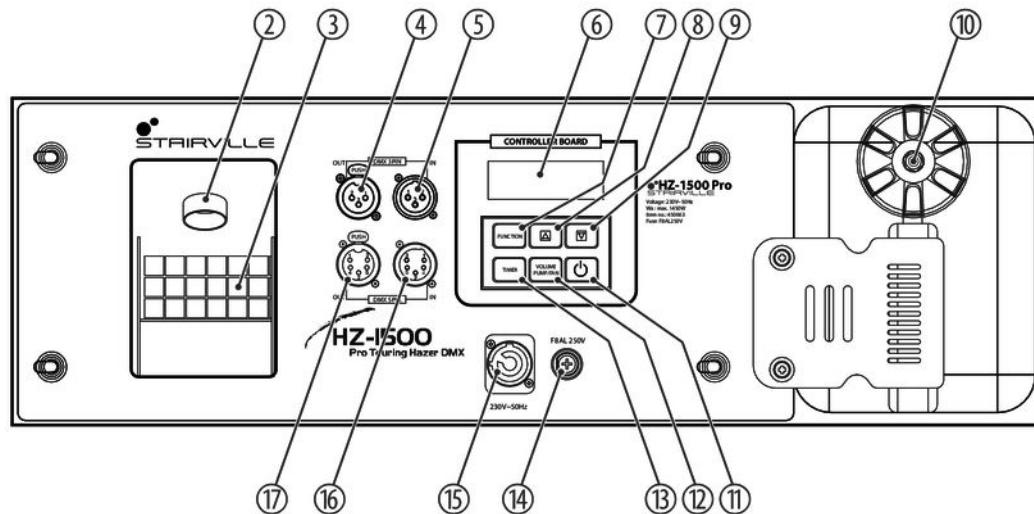

2	Fastening piece for hazer fluid hose
3	Haze nozzle
4	<i>[DMX 3PIN OUT]</i> DMX output, 3-pin
5	<i>[DMX 3PIN IN]</i> DMX input, 3-pin
6	Display
7	<i>[FUNCTION]</i> Opens the settings menu.
8	▲ Increases the displayed value by one and selects menu items. During operation: Increases the amount of haze.
9	▼ Decreases the displayed value by one and selects menu items. During operation: Decreases the amount of haze.

10	Fluid tank cap
11	<p>⏻: <i>[ON/OFF]</i></p> <p>Press and hold ⏻ for 1 second: The current function of the device is stopped.</p> <p>Press and hold ⏻ for 2 seconds: The device performs a self-cleaning (duration about 5 minutes) and is then switched to standby mode.</p>
12	<p><i>[VOLUME PUMP/FAN]</i></p> <p>Activates the haze emission in continuous operation.</p>
13	<p><i>[TIMER]</i></p> <p>Activates the haze emission in interval operation.</p>
14	Fuse holder
15	Lockable input socket (Power Twist) for powering the device

16	<i>[DMX 5PIN IN]</i> DMX input, 5-pin
17	<i>[DMX 5PIN OUT]</i> DMX output, 5-pin

7 Operating

Filling the unit



NOTICE!

Possible damages caused by unsuitable hazer fluid

Hazer fluids not approved by the manufacturer may permanently damage the unit.

Only use the hazer fluids listed on www.thomann.de and follow their instructions for use.

First, make sure the unit is switched off.

Open the screw-cap of the liquid container and fill in the hazer fluid. Make sure that no hazer fluid is spilled or gets into the device. The easiest way is using a funnel. The container capacity is 3 litre.

Screw the cap firmly back on.

Turning the unit on



NOTICE!

Fire hazard

Do not operate the machine unattended.

Connect the device to the mains power grid and turn it on with the main switch. The display shows the software version (display shows *'HZ-1500 version V0.1'*).

During the heat-up time of approx. 50 seconds, the display shows the status of the heating process in alternation with the software version (display shows *'HZ-1500 heating 0%' ... 'HZ-1500 heating 100%'*). When the heat-up process is completed, the display will change to *'HZ-1500 Pro Machine Ready'*, alternating with the software version. The device is now operational.

Main menu

When the device is ready, you can access the menu functions and set the desired values of the functions.

1. ▶ Press *[FUNCTION]* repeatedly until the desired submenu is displayed.
2. ▶ Use *[UP]* or *[DOWN]* to select the desired value.
⇒ The desired value is applied automatically.

Interval between two haze blasts

1. ▶ Press *[FUNCTION]* repeatedly until the display shows '*Interval time set: 10S'*.
2. ▶ Use *[UP]* or *[DOWN]* to select a value between 1 and 600 seconds (display shows '*1S... 600S'*').
⇒ The desired value is applied.

Haze blast duration

1. ➤ Press *[FUNCTION]* repeatedly until the display shows '*Duration time set: 10S*'.
2. ➤ Use *[UP]* or *[DOWN]* to select a value between 1 and 600 seconds (display shows '*1S... 600S*').
 - ⇒ The desired value is applied.

Haze amount

1. ➤ Press *[FUNCTION]* until the display shows '*Timer Smoke Volume Out: 50%*'.
2. ➤ Use *[UP]* or *[DOWN]* to select a value between 1 and 100 percent (display shows '*1%... 100%*').
 - ⇒ The desired value is applied.

Fan power

1. ➤ Press *[FUNCTION]* repeatedly until the display shows '*Fan Adjusting speed: 100%*'.
2. ➤ Use *[UP]* or *[DOWN]* to select a value between 1 and 100 percent (display shows '*1%... 100%*').
 - ⇒ The desired value is applied.

Operating mode 'DMX'

1. ➤ Press *[FUNCTION]* repeatedly until the display shows '*DMX address set: 1*'.
2. ➤ Use *[UP]* or *[DOWN]* to select the desired DMX address in a range between 1 and 511.
 - ⇒ The desired value is applied.

Make sure that the DMX address matches the configuration of your DMX controller.

DMX assignment

Channel	Value	Function
1	Setting the amount of haze	
	0...255	No haze output (0 %) to maximum haze output (100 %)
2	Setting the blower power	
	0...255	Minimum blower power (0 %) to maximum blower power (100 %)

Haze output in continuous operation

1. ▶ Press ϕ until the display shows 'Machine Ready'.
2. ▶ Press [VOLUME PUMP/FAN] to activate continuous haze output.
 - ⇒ The display shows the values set in the haze amount menu (display shows 'Haze 1% ... 100%') and blower power (display shows 'Fan 1%... 100%'). The haze output is activated with the preset values. Use [FUNCTION] to change the selection between 'Haze' and 'Fan', use [UP] and [DOWN] to increase or decrease the selected value.
3. ▶ To end the function, press ϕ .

Haze output in interval operation

1. ▶ Press ϕ until the display shows *'Machine Ready'*.
2. ▶ Press *[TIMER]* to activate haze output in interval operation.
 - ⇒ The display shows the values set in the menu for the interval between two blasts (display shows *'Interval: 1S...600S'*) as well as the blast duration (display shows *'Duration: 1S...600S'*). The haze output is activated with the preset values.
3. ▶ To end the function, press ϕ .

Turning the unit off

1. ▶ Press \odot to exit all functions and put the device into standby mode.
 - ⇒ The device performs a self-cleaning to rid the hose and nozzle of fluid residues. This process takes about 5 minutes. Do not interrupt this process.
2. ▶ When the cleaning process is completed, the display shows the message *'Please power off'*.
 - ⇒ You can now disconnect the device from the power supply.

Transport the device only when it is completely cooled down. To avoid leaking hazer fluid during transport, you should transport the device only with empty fluid container.

8 Technical specifications

Fluid container capacity	3 l
Fluid consumption	12 ml/min @ 100 % emission
Warm-up time	approx. 50 s (\pm 20 s)
Heater power	1450 W
For burst duration, max.	continuously @ max. 50 % output volume, adjustable from 1...100 %
Operating supply voltage	AC 230 V ~ 50 Hz
Fuse	5 mm \times 20 mm, 8 A, 250 V, fast-acting
Dimensions (W \times H \times D)	490 mm \times 345 mm \times 170 mm
Weight	16.45 kg (without fluid)

9 Plug and connection assignment

Introduction

This chapter will help you select the right cables and plugs to connect your valuable equipment so that a perfect light experience is guaranteed.

Please take our tips, because especially in 'Sound & Light' caution is indicated: Even if a plug fits into a socket, the result of an incorrect connection may be a destroyed DMX controller, a short circuit or 'just' a not working light show!

DMX connections



The unit offers a 3-pin XLR socket for DMX output and a 3-pin XLR plug for DMX input. Please refer to the drawing and table below for the pin assignment of a suitable XLR plug.

Pin	Configuration
1	Ground, shielding
2	Signal inverted (DMX-, 'cold signal')
3	Signal (DMX+, 'hot signal')

DMX connections



A five-pin XLR socket serves as DMX output, a five-pin XLR plug serves as DMX input. The drawing below and the table show the pin assignment of a matching coupling.

Pin	Assignment
1	Ground (shielding)
2	Signal inverted (DMX-, 'cold')
3	Signal (DMX+, 'hot')
4	unused / second connection (DMX-)
5	unused / second connection (DMX+)

10 Troubleshooting

In the following we list a few common problems that may occur during operation. We give you some suggestions for easy troubleshooting:

Symptom	Remedy
The unit does not work	Check the mains connection and main fuse.
No haze output	<ol style="list-style-type: none"> <li data-bbox="624 288 1525 337">1. Check the fluid level of the hazer fluid. <li data-bbox="624 339 1525 412">2. Switch the device off and check the hose that leads into the fluid container for flow. <li data-bbox="624 414 1525 493">3. Check that the quick connector closes completely and sits securely in the locking system.
No response to the DMX controller	<ol style="list-style-type: none"> <li data-bbox="624 496 1525 544">1. Check the address settings and the DMX polarity. <li data-bbox="624 546 1525 594">2. Try using another DMX controller. <li data-bbox="624 596 1525 673">3. Check whether the DMX cables run near or parallel to high-voltage cables that may cause damage or interference to a DMX interface circuit.
The display shows the message <i>'Beware: No Liquid!'</i>	<ol style="list-style-type: none"> <li data-bbox="624 675 1525 723">1. Disconnect the unit from the power supply. <li data-bbox="624 725 1525 767">2. Fill in suitable hazer fluid.

If the procedures recommended above do not succeed, please contact our Service Center. You can find the contact information at www.thomann.de.

11 Cleaning



NOTICE!

Possible damages caused by unsuitable cleaning agents

Cleaners not approved by the manufacturer may permanently damage the unit.

Only use the cleaning agents listed on www.thomann.de and follow their instructions for use.

Clean the appliance after every 30 operating hours, or if it was not in use for a longer period of time.

Procedure

1. ➤ Make sure that the device is turned off, disconnected from the mains and completely cooled down.
2. ➤ Position the unit in a well ventilated place.

3. ➤ Insert the suction hose of the device into the bottle containing the cleaning agent.
4. ➤ Connect the device to the mains power grid and turn it on with the main switch.
5. ➤ Wait until the unit has reached the required operating temperature.
6. ➤ Switch the unit to continuous operation and let it produce fog / haze for about 20 seconds.
7. ➤ Insert the suction hose of the device back into the fluid container and let the device again produce fog / haze for about 20 seconds. This will rinse the lines.
 - ⇒ The cleaning is completed.

Fan grids

The fan grids of the device must be cleaned on a regular basis to remove dust and dirt. Before cleaning, switch off the device and disconnect AC-powered devices from the mains. Use a lint-free damp cloth for cleaning. Never use solvents or alcohol for cleaning.

Regularly unscrew the ventilation grille and clean the filter behind it under running clear water. Allow the filter to dry and reinsert it before next use. Now screw on the ventilation grille again.

12 Protecting the environment

Disposal of the packaging material



For the transport and protective packaging, environmentally friendly materials have been chosen that can be supplied to normal recycling.

Ensure that plastic bags, packaging, etc. are properly disposed of.

Do not just dispose of these materials with your normal household waste, but make sure that they are collected for recycling. Please follow the notes and markings on the packaging.

Disposal of your old device



This product is subject to the European Waste Electrical and Electronic Equipment Directive (WEEE) in its currently valid version. Do not dispose with your normal household waste.

Dispose of this device through an approved waste disposal firm or through your local waste facility. When discarding the device, comply with the rules and regulations that apply in your country. If in doubt, consult your local waste disposal facility.



