



GigA Pro Cam Set PT wireless system



Musikhaus Thomann
Thomann GmbH
Hans-Thomann-Straße 1
96138 Burgebrach
Germany
Telephone: +49 (0) 9546 9223-0
E-mail: info@thomann.de
Internet: www.thomann.de

10.07.2019, ID: 453985

Table of contents

1	General information	5
	1.1 Further information.....	6
	1.2 Notational conventions.....	7
	1.3 Symbols and signal words.....	8
2	Safety instructions	10
3	Features	15
4	Installation and starting up	18
	4.1 General Information.....	18
	4.2 Dealing with lithium batteries.....	20
	4.3 Receiver.....	21
5	Connections and controls	22
	5.1 Receiver.....	22
	5.2 Bodypack transmitter.....	25
6	Operating	28
	6.1 Receiver.....	28

6.2	Bodypack transmitter.....	35
7	Technical specifications.....	37
7.1	Receiver.....	37
7.2	Bodypack transmitter.....	39
8	Plug and connection assignment.....	41
9	Troubleshooting.....	43
10	Protecting the environment.....	45

1 General information

This user manual contains important information on the safe operation of the device. Read and follow all safety notes and all instructions. Save this manual for future reference. Make sure that it is available to all persons using this device. If you sell the device to another user, be sure that they also receive this manual.

Our products and user manuals are subject to a process of continuous development. We therefore reserve the right to make changes without notice. Please refer to the latest version of the user manual which is ready for download under www.thomann.de.

1.1 Further information

On our website (www.thomann.de) you will find lots of further information and details on the following points:

Download	This manual is also available as PDF file for you to download.
Keyword search	Use the search function in the electronic version to find the topics of interest for you quickly.
Online guides	Our online guides provide detailed information on technical basics and terms.
Personal consultation	For personal consultation please contact our technical hotline.
Service	If you have any problems with the device the customer service will gladly assist you.

1.2 Notational conventions

This manual uses the following notational conventions:

Letterings

The letterings for connectors and controls are marked by square brackets and italics.

Examples: *[VOLUME]* control, *[Mono]* button.

Instructions

The individual steps of an instruction are numbered consecutively. The result of a step is indented and highlighted by an arrow.

Example:

1. ➤ Switch on the device.
2. ➤ Press *[Auto]*.
 - ⇒ Automatic operation is started.
3. ➤ Switch off the device.

1.3 Symbols and signal words

In this section you will find an overview of the meaning of symbols and signal words that are used in this manual.

Signal word	Meaning
DANGER!	This combination of symbol and signal word indicates an immediate dangerous situation that will result in death or serious injury if it is not avoided.
WARNING!	This combination of symbol and signal word indicates a possible dangerous situation that can result in death or serious injury if it is not avoided.
NOTICE!	This combination of symbol and signal word indicates a possible dangerous situation that can result in material and environmental damage if it is not avoided.

Warning signs	Type of danger
	Warning – danger zone.

2 Safety instructions

Intended use

This device is intended to be used for the wireless transmission of audio signals from microphones or instruments to amplifiers or active speakers. Use the device only as described in this user manual. Any other use or use under other operating conditions is considered to be improper and may result in personal injury or property damage. No liability will be assumed for damages resulting from improper use.

This device may be used only by persons with sufficient physical, sensorial, and intellectual abilities and having corresponding knowledge and experience. Other persons may use this device only if they are supervised or instructed by a person who is responsible for their safety.

Safety



DANGER!

Danger for children

Ensure that plastic bags, packaging, etc. are disposed of properly and are not within reach of babies and young children. Choking hazard!

Ensure that children do not detach any small parts (e.g. knobs or the like) from the unit. They could swallow the pieces and choke!

Never let children unattended use electrical devices.



NOTICE!

Operating conditions

This device has been designed for indoor use only. To prevent damage, never expose the device to any liquid or moisture. Avoid direct sunlight, heavy dirt, and strong vibrations.

Only operate the device within the ambient conditions specified in the chapter 'Technical specifications' of this user manual. Avoid heavy temperature fluctuations and do not switch the device on immediately after it was exposed to temperature fluctuations (for example after transport at low outside temperatures).

Dust and dirt inside can damage the unit. When operated in harmful ambient conditions (dust, smoke, nicotine, fog, etc.), the unit should be maintained by qualified service personnel at regular intervals to prevent overheating and other malfunction.



NOTICE!

Risk of fire due to incorrect polarity

Incorrectly inserted batteries may destroy the device or the batteries.

Ensure that proper polarity is observed when inserting batteries.



NOTICE!

Possible damage by leaking batteries

Leaking batteries can cause permanent damage to the device.

Take batteries out of the device if it is not going to be used for a longer period.



NOTICE!

Possible damage due to incorrect storage

Deep discharge can cause batteries to become permanently damaged or lose some of their capacity.

Before prolonged rest periods, charge the batteries to around 50 % of their capacity and then switch the equipment off. Store the equipment at a temperature between 10 °C and 32 °C in as dry an environment as possible. During extended storage periods, charge the batteries to 50 % approximately every three months.

3 Features

The Wireless System GigA Pro Cam Set PT consists of the following components:

- GigA Pro BR Bodypack Receiver
 - 2.4-GHz-diversity receiver with flash shoe adapter
 - Two fixed antennas for optimum reception quality
 - Infrared interface for ACT sync
 - Lithium battery operation (1 × ICR 18500), with up to 10 hours battery life
 - Charging contacts for battery charging station GigA Pro BC2
 - Three-digit display for battery capacity
- GigA Pro BT Bodypack Transmitter
 - Pushbutton and external input for muting
 - Mini XLR (TQG) input
 - Flexible stub antenna
 - Infrared interface for ACT sync
 - Lithium battery operation (1 × ICR 18500), with up to 10 hours battery life
 - Charging contacts for battery charging station GigA Pro BC2
 - Three-digit display for battery capacity
 - Belt clip

The system operates at 2.400 GHz ... 2.4835 GHz and is worldwide free of charge and registration.

Components and sets

		Vocal Set	Body Set	Pedal Set	Wind Set	Cam Set PT	Cam Set HT
Components	Article	313901	313903	437954	453984	453985	453987
Bodypack Transmitter	314031		x			x	
Bodypack Receiver	453669					x	x
Handheld Transmitter	314033	x					x
Receiver	314034	x	x		x		
GT	453986			x	x		
BC2	398020	x	x				
Wind Mic	454560				x		
Pedal Board Receiver (PBR)*				x			
MP-24 for GT *				x	x		

* not available separately

4 Installation and starting up

4.1 General Information

Unpack and check carefully there is no transportation damage before using the unit. Keep the equipment packaging. To fully protect the product against vibration, dust and moisture during transportation or storage use the original packaging or your own packaging material suitable for transport or storage, respectively.

Create all connections while the device is off. Use the shortest possible high-quality cables for all connections. Take care when running the cables to prevent tripping hazards.

Notes on wireless transmission

- This device utilizes frequencies that are not harmonized within the European Union (EU) and therefore may only be used in certain EU member states. In all European countries, the frequencies used for the transmission of audio signals are strictly regulated. Before you start, make sure the frequencies are allowed in the respective country and check whether the operation must be reported to the appropriate authority.
For more information, please visit: <http://www.thomann.de>.
- Make sure that transmitter and receiver are both tuned to the same channel.
- Never set multiple transmitters to the same channel.
- Make sure that there are no metal objects between the transmitter and receiver.
- Avoid interference from other radio or in-ear systems.

4.2 Dealing with lithium batteries



WARNING!

Incorrect handling of lithium batteries can result in injury

In the event of a short circuit, overheating or mechanical damage, lithium batteries can cause severe injuries.

Follow the advice on the correct handling of lithium batteries in the present section.

When handled correctly and appropriately lithium batteries pose no risk.

Store lithium batteries in a cool, dry place, ideally in the original packaging.

Store lithium batteries away from heat sources (e.g. radiators or sunlight). Lithium batteries are hermetically sealed. Never attempt to open a lithium battery.

If the battery housing is damaged small amounts of the electrolyte may leak out. If this should happen, seal the lithium battery in airtight packaging and wipe up the traces of electrolyte using absorbent paper towels. You must wear protective rubber gloves when doing so. Clean your hands and the affected surface thoroughly with cold water.

Never attempt to recharge non-rechargeable lithium batteries. When charging lithium batteries you must use a suitable charging device intended for the purpose.

Before disposing of the device remove the lithium batteries. Protect used lithium batteries against potential short circuits, e.g. by covering the poles with adhesive tape.

Only use powder extinguishers or other suitable extinguishing agents to extinguish a burning lithium battery.

4.3 Receiver

Inserting batteries into the receiver

Turn the battery compartment latches into vertical position. Press on the snap-in locks at the side to open the battery compartment. Flip the lid open and insert the batteries. Pay attention to the correct location of the poles. Close the battery compartment and turn the battery compartment latches into horizontal position.

5 Connections and controls

5.1 Receiver

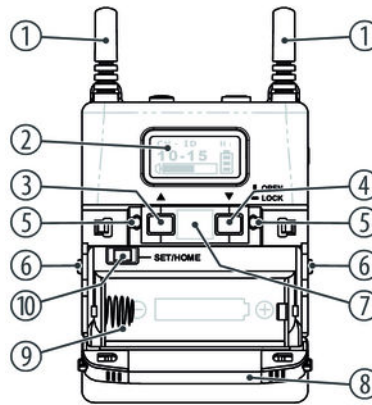

Front panel	
1	Antenna
2	Display
3	▲[MODE] Increases the displayed value.
4	▼[/ACT/SET] Decreases the displayed value.
5	Battery compartment latches
6	Snap-in lock
7	Infrared interface for synchronization (ACT-Sync)
8	Battery compartment lid
9	Battery compartment
10	[SET/HOME] Calls up the setting mode.

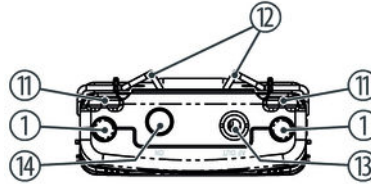

Top side

1	Antenna
11	Suspension lug
12	Clip to attach the receiver to your belt or guitar strap
13	<i>[AF OUT]</i> 3.5 mm phone socket (stereo) for the ear phones
14	<i>[ON]</i> Main switch. Turns the device on and off.

5.2 Bodypack transmitter

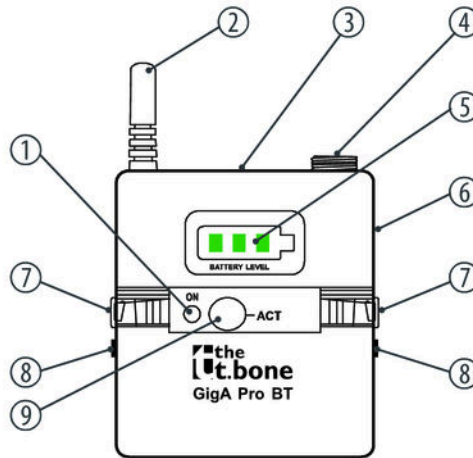

1	<i>[ON]</i> Main switch. Press the switch for several seconds to switch the device on or off.
2	Antenna
3	<i>[AF]</i> Transmitter mute button. The switch lights up when the transmitter is active. Press the button to mute the transmitter.
4	Mini-XLR chassis plug for connecting a microphone or instrument.
5	Battery status indicator If the last remaining segment lights up red, at most 25% of the battery capacity remains.
6	3.5 mm phone socket to connect an optionally available external mute button.
7	Snap locks for the battery compartment.
8	Charging contacts.

9 [ACT]

Infrared sensor

Under the battery compartment cover is the button for resetting the battery monitor.

6 Operating

6.1 Receiver

Switching the device on / off

- 1.** ➤ Press the [ON] power switch on the top of the device to turn on the device.
⇒ The display lights up and displays the current channel and battery status. After a few seconds, the display is dimmed automatically.
- 2.** ➤ Press [ON] again to turn the device off.



The device will not power on with insufficient battery power. In this case, insert a fully charged rechargeable battery.

Setting the output level

- ➔ Press ▼ or ▲ to set the output level. The level can be adjusted in a range from –10... +20 dB.

Parameter setup



The [SET/HOME] button that you need to set up the receiver is located under the battery compartment lid.

- ➔ 1. Open the battery compartment to access [SET/HOME].
- ➔ 2. Press and hold [SET/HOME] to call the parameter setup mode.
 - ⇒ The display shows 'ACT' next to the current channel and ID assignment.
- ➔ 3. To exit the parameter setup mode, press and hold [SET/HOME] again until 'ACT' disappears.

Select channel

1. ▶ Enter the parameter setup mode and press ▲[/MODE] until the display shows 'CH-ID'.
2. ▶ Press ▼[/ACT/SET] until the channel number (left value) is blinking.
3. ▶ During blinking, press ▼[/ACT/SET] until the desired channel number is displayed.
4. ▶ Press ▲[/MODE] to save the value.

With the channel selection you can select the channel with less interferences.

ID selecting

The ID adjustable in addition to the channel increases the transmission reliability.

1. ▶ Enter the parameter setup mode and press ▲[/MODE] until the display shows 'CH-ID'.
2. ▶ Press ▼[/ACT/SET] once, then press ▲[/MODE] once.
⇒ The ID-number is blinking.
3. ▶ During blinking, press ▼[/ACT/SET] until the desired value is displayed.
4. ▶ Press ▲[/MODE] to save the value.

Adjusting radio signal level

1. ➤ Enter the parameter setup mode and press ▲[*MODE*] until the display shows '*RF POWER*'.
2. ➤ Press ▼[*ACT/SET*] once.
⇒ The cursor is blinking.
3. ➤ During blinking, press ▼[*ACT/SET*] to choose between high ('*HIGH*') or low ('*LOW*') level.
4. ➤ Press ▲[*MODE*] to save the value.
5. ➤ Press ▼[*ACT/SET*] to transmit the new settings to the paired receiver.

Setting bass filter

1. ▶ Enter the parameter setup mode and press ▲[/MODE] until the display shows 'EQUALIZER'.
2. ▶ Press ▼[/ACT/SET] once.
⇒ The cursor is blinking.
3. ▶ During blinking, press ▼[/ACT/SET] to activate ('LOW-CUT') or deactivate ('FLAT') the bass filter.
4. ▶ Press ▲[/MODE] to save the value.

The filter is used to suppress annoying hum or rumbling noises.

Lock settings

1. ▶ Enter the parameter setup mode and press ▲[/MODE] until the display shows 'SET LOCK'.
2. ▶ Press ▼[/ACT/SET] once.
 - ⇒ The cursor is blinking.
3. ▶ During blinking, press ▼[/ACT/SET] to lock ('LOCK') or unlock ('UNLOCK') the settings lock.
 - ⇒ In the 'LOCK' status, no changes can be made to channel, ID or other configuration parameters.
4. ▶ Press ▲[/MODE] to save the value.

The lock settings function protects against unintentional changes to the device configuration.

Synchronizing transmitter and receiver

1. ➤ Call up the parameter setup mode.
 2. ➤ Turn on the transmitter and point it directly at the infrared interface of the receiver. The distance between the devices must not exceed 10 cm.
 3. ➤ Press ▼[/ACT/SET].
 - ⇒ The two devices are synchronized. All settings made are transferred automatically. Once the synchronization is complete, the display will return to the initial state, indicating the level of the radio signal and the volume.
- If the synchronization has failed, the message 'FAIL' appears. In this case, hold the transmitter closer to the receiver and restart the synchronization.

6.2 Bodypack transmitter

Engaging transmitter

1. ▶ Connect a microphone or your instrument to the Mini XLR chassis plug before turning on the transmitter. Make sure to screw plug and socket together. If you want to use an available external mute switch, connect it also before turning it on.
2. ▶ Press *[ON]*.
 - ⇒ The battery level indicator and the *[AF]* button light up.
3. ▶ If the last remaining segment of the battery level indicator lights up red, at most 25 % of the battery capacity remains.

In this case, recharge the transmitter in the charger or replace the empty battery with a charged one.

Turning the transmitter off

Press *[ON]* for several seconds until the battery level indicator goes out.

Mute

Press *[AF]* to mute or unmute the transmitter. When the button lights up, the transmitter is active. You can also use an optionally available external mute switch instead of the button.

Battery replacement

1. ▶ Turn the transmitter off.
2. ▶ Press the two side latches together to open the battery compartment cover.
3. ▶ Remove the empty battery and replace it with a charged one. Observe the correct polarity. Seen from the front, the positive pole is on the right side.
4. ▶ Should the transmitter also fail to work with a freshly charged battery, turn the transmitter off. Press the button to reset the battery monitor to 'wake up' the battery.
5. ▶ Close the battery compartment and turn the transmitter back on.

7 Technical specifications

7.1 Receiver

Max. number of parallel systems	10 systems	
Output connections	Earphones	3.5 mm mini phone socket (stereo)
Output level adjustment	-10...+20 dB	
Frequency range	2.400 GHz ... 2.4835 GHz	
Battery	Battery type	1 × lithium-ion rechargeable battery (ICR18500)
	Voltage	3.7 V
	Capacity	1400 mAh
	Operating time	4 h (after 4 hours of charging time)
Dimensions (W × H × D), without antennas	63 mm × 25 mm × 70 mm	

Weight	85 g	
Ambient conditions	Temperature range	0 °C...40 °C
	Relative humidity	50 %, non-condensing

Further information

Frequency band	2.4 GHz
Diversity	Yes
Bodypack transmitter	No
Handheld transmitter	No
Clip-on transmitter	No
Power supply transmitter	Rechargeable battery
Frequency	2400...2438

7.2 Bodypack transmitter

Frequency range	2.400 GHz ... 2.4835 GHz	
Maximum transmission power	10 mW	
Maximum input level	6.5 dBV	
Input impedance	1,0 MΩ	
Range (free field)	Up to 100 m	
Battery	Battery type	1 × lithium-ion rechargeable battery ICR-18500
	Voltage	3.7 V
	Capacity	1400 mAh
	Operating time	> 1 h (after 25 minutes of charging time), > 10 h (after four hours of charging time)

Technical specifications

Dimensions (W × H × D, without antenna)	63 mm × 70 mm × 25 mm	
Weight	66 g	
Ambient conditions	Temperature range	0 °C...40 °C
	Relative humidity	50 %, non-condensing

8 Plug and connection assignment

Introduction

This chapter will help you select the right cables and plugs to connect your valuable equipment in such a way that a perfect sound experience is ensured.

Please note these advices, because especially in 'Sound & Light' caution is indicated: Even if a plug fits into the socket, an incorrect connection may result in a destroyed power amp, a short circuit or 'just' in poor transmission quality!

Balanced and unbalanced transmission

Unbalanced transmission is mainly used in semi-professional environment and in hifi use. Instrument cables with two conductors (one core plus shielding) are typical representatives of the unbalanced transmission. One conductor is ground and shielding while the signal is transmitted through the core.

Unbalanced transmission is susceptible to electromagnetic interference, especially at low levels, such as microphone signals and when using long cables.

In a professional environment, therefore, the balanced transmission is preferred, because this enables an undisturbed transmission of signals over long distances. In addition to the conductors 'Ground' and 'Signal', in a balanced transmission a second core is added. This also transfers the signal, but phase-shifted by 180°.

Since the interference affects both cores equally, by subtracting the phase-shifted signals, the interfering signal is completely neutralized. The result is a pure signal without any noise interference.

Three-pole 1/8" mini phone jack (stereo, unbalanced)



1	Signal (left)
2	Signal (right)
3	Ground, shielding

Mini XLR



1	Ground
2	Positive signal (+)
3	Negative signal (-)

9 Troubleshooting

In the following we list a few common problems that may occur during operation. We give you some suggestions for easy troubleshooting:

Symptom	Remedy
No sound	1. Check the power supply of transmitter and receiver.
	2. Make sure that transmitter and receiver are operating in the same frequency range. The frequency range can be found on the devices.
	3. Are transmitter and receiver set to the same channel and ID?
	4. Test the connection between the receiver and the connected audio device (amplifier, mixer). Is the connected audio device turned on and does the signal level at the output of the receiver match the input requirements of the audio device?
	5. See if the audio transmission works when you move the transmitter closer to the receiver.

Symptom	Remedy
	6. Make sure that no metal objects near the transmitter or receiver obstruct the transmission.
Transmission is interrupted	1. Modify the orientation of the antennas.
	2. If you use more than one wireless system at the same time, check the used frequencies and channels.
	3. Interference can also be caused by other radio or in-ear systems.

If the procedures recommended above do not succeed, please contact our Service Center. You can find the contact information at www.thomann.de.

10 Protecting the environment

Disposal of the packaging material



For the packaging, environmentally friendly materials have been chosen that can be supplied to normal recycling.

Ensure that plastic bags, packaging, etc. are properly disposed of.

Do not just dispose of these materials with your normal household waste, but make sure that they are collected for recycling. Please follow the notes and markings on the packaging.

Disposal of batteries



Batteries do contain some hazardous chemicals so they should not be thrown away with the normal household waste. They should be returned to the manufacturer for disposal or recycled elsewhere in accordance with your local regulations.

Remove lithium batteries from the device before disposal. Protect used lithium batteries against short circuit, for example by taping the poles.

Disposal of your old device



This product is subject to the European Waste Electrical and Electronic Equipment Directive (WEEE) in its currently valid version. Do not dispose with your normal household waste.

Dispose of this device through an approved waste disposal firm or through your local waste facility. When discarding the device, comply with the rules and regulations that apply in your country. If in doubt, consult your local waste disposal facility.



Musikhaus Thomann · Hans-Thomann-Straße 1 · 96138 Burgebrach · Germany · www.thomann.de