



RED Spot 18 RGB
BLACK Spot 18 RGB
LED PAR

Musikhaus Thomann
Thomann GmbH
Hans-Thomann-Straße 1
96138 Burgebrach
Germany
Telephone: +49 (0) 9546 9223-0
E-mail: info@thomann.de
Internet: www.thomann.de

02.10.2019, ID: 463465, 465199

Table of contents

1	General information	5
	1.1 Further information.....	6
	1.2 Notational conventions.....	7
	1.3 Symbols and signal words.....	7
2	Safety instructions	10
3	Features	16
4	Installation	17
5	Starting up	21
6	Connections and controls	24
7	Operating	27
	7.1 Functions in 4-channel DMX mode.....	28
	7.2 Functions in 7-channel DMX mode.....	29
8	Technical specifications	31
9	Plug and connection assignments	34

10	Troubleshooting.....	35
11	Cleaning.....	37
12	Protecting the environment.....	38

1 General information

This user manual contains important information on the safe operation of the device. Read and follow all safety notes and all instructions. Save this manual for future reference. Make sure that it is available to all persons using this device. If you sell the device to another user, be sure that they also receive this manual.

Our products and user manuals are subject to a process of continuous development. We therefore reserve the right to make changes without notice. Please refer to the latest version of the user manual which is ready for download under www.thomann.de.

1.1 Further information

On our website (www.thomann.de) you will find lots of further information and details on the following points:

Download	This manual is also available as PDF file for you to download.
Keyword search	Use the search function in the electronic version to find the topics of interest for you quickly.
Online guides	Our online guides provide detailed information on technical basics and terms.
Personal consultation	For personal consultation please contact our technical hotline.
Service	If you have any problems with the device the customer service will gladly assist you.

1.2 Notational conventions

This manual uses the following notational conventions:

Letterings

The letterings for connectors and controls are marked by square brackets and italics.

Examples: *[VOLUME]* control, *[Mono]* button.



Displays



Texts and values displayed on the device are marked by quotation marks and italics.

Examples: *'24ch'*, *'OFF'*.

1.3 Symbols and signal words

In this section you will find an overview of the meaning of symbols and signal words that are used in this manual.

Signal word	Meaning
DANGER!	This combination of symbol and signal word indicates an immediate dangerous situation that will result in death or serious injury if it is not avoided.
WARNING!	This combination of symbol and signal word indicates a possible dangerous situation that can result in death or serious injury if it is not avoided.
NOTICE!	This combination of symbol and signal word indicates a possible dangerous situation that can result in material and environmental damage if it is not avoided.
Warning signs	Type of danger
	Warning – high-voltage.
	Warning – dangerous optical radiation.

Warning signs	Type of danger
	Warning – suspended load.
	Warning – danger zone.

2 Safety instructions

Intended use

This device is intended for use as an electronic lighting effect by means of LED technology. The device is designed for professional use and is not suitable for use in households. Use the device only as described in this user manual. Any other use or use under other operating conditions is considered to be improper and may result in personal injury or property damage. No liability will be assumed for damages resulting from improper use.

This device may be used only by persons with sufficient physical, sensorial, and intellectual abilities and having corresponding knowledge and experience. Other persons may use this device only if they are supervised or instructed by a person who is responsible for their safety.

Extend the life of the device by regular breaks in operation and avoid switching it on and off frequently. This device is not suitable for continuous use.

Safety



DANGER!

Danger for children

Ensure that plastic bags, packaging, etc. are disposed of properly and are not within reach of babies and young children. Choking hazard!

Ensure that children do not detach any small parts (e.g. knobs or the like) from the unit. They could swallow the pieces and choke!

Never let children unattended use electrical devices.



DANGER!

Electric shock caused by high voltages inside

Within the device there are areas where high voltages may be present. Never remove any covers.

There are no user-serviceable parts inside.

Do not use the device if covers, protectors or optical components are missing or damaged.



DANGER!

Electric shock caused by short-circuit

Always use proper ready-made insulated mains cabling (power cord) with a protective contact plug. Do not modify the mains cable or the plug. Failure to do so could result in electric shock/death or fire. If in doubt, seek advice from a registered electrician.



WARNING!

Eye damage caused by high light intensity

Never look directly into the light source.



WARNING!

Risk of epileptic shock

Strobe lighting can trigger seizures in photosensitive epilepsy. Sensitive persons should avoid looking at strobe lights.



NOTICE!

Risk of fire

Do not block areas of ventilation. Do not install the device near any direct heat source. Keep the device away from naked flames.



NOTICE!

Operating conditions

This device has been designed for indoor use only. To prevent damage, never expose the device to any liquid or moisture. Avoid direct sunlight, heavy dirt, and strong vibrations.

Only operate the device within the ambient conditions specified in the chapter 'Technical specifications' of this user manual. Avoid heavy temperature fluctuations and do not switch the device on immediately after it was exposed to temperature fluctuations (for example after transport at low outside temperatures).

Dust and dirt inside can damage the unit. When operated in harmful ambient conditions (dust, smoke, nicotine, fog, etc.), the unit should be maintained by qualified service personnel at regular intervals to prevent overheating and other malfunction.



NOTICE!

Power supply

Before connecting the device, ensure that the input voltage (AC outlet) matches the voltage rating of the device and that the AC outlet is protected by a residual current circuit breaker. Failure to do so could result in damage to the device and possibly injure the user.

Unplug the device before electrical storms occur and when it is unused for long periods of time to reduce the risk of electric shock or fire.



NOTICE!

Possible damage due to installation of a wrong fuse

The use of different types of fuses can cause serious damage to the unit. Fire hazard!

Only fuses of the same type may be used.

3 Features

The LED PAR is particularly suitable for professional lighting tasks, for example at events, on rock stages and in theatres and musicals. The device is characterised by compact design and particularly high light output.

Special features of the device:

- 18 × 1 watt LEDs (6 × red, 6 × green, 6 × blue)
- Control via DMX or via buttons and display on the unit
- Automatic programme run
- Sound control
- Master / Slave mode
- Robust metal housing

For technological reasons, the light output of LEDs decreases over their lifetime. This effect increases with higher operating temperature. You can extend the service life of the illuminants by providing adequate ventilation and operating the LEDs with the lowest possible brightness.

4 Installation

Unpack and check carefully there is no transportation damage before using the unit. Keep the equipment packaging. To fully protect the product against vibration, dust and moisture during transportation or storage use the original packaging or your own packaging material suitable for transport or storage, respectively.



WARNING!

Risk of injury caused by falling objects

Make sure that the installation complies with the standards and rules that apply in your country. Always secure the device with a secondary safety attachment, such as a safety cable or a safety chain.



NOTICE!

Risk of overheating

The distance between light output and the illuminated surface must be more than 1.5 m (19.7in).

Provide sufficient ventilation.

The ambient temperature must always be below 40 °C (104 °F).



NOTICE!

Use of stands

When mounting the device onto a stand, ensure that the stand is in a safe and stable position and that the weight of the device does not exceed the maximum permissible load capacity of the stand.



NOTICE!

Possible data transmission errors

For error-free operation make use of dedicated DMX cables and do not use ordinary microphone cables.

Never connect the DMX input or output to audio devices such as mixers or amplifiers.



Please note that this device must not be connected to a dimmer.

Mounting options

You can install the unit in hanging or standing position. When in use, the device must always be attached to a solid surface or an approved truss. Use the openings provided on the two-piece bracket for attaching.

Always work from a stable platform whenever installing, moving or servicing the unit. In doing so, the area underneath the unit must be cordoned off.

Additionally secure the device by a safety cable against falling.

5 Starting up

Create all connections while the device is off. Use the shortest possible high-quality cables for all connections. Take care when running the cables to prevent tripping hazards.

Connections in DMX mode

Connect the DMX input of the device to the DMX output of a DMX controller or another DMX device. Connect the output of the first DMX device to the input of the second one, and so on to form a daisy chain. Always ensure that the output of the last DMX device in the daisy chain is terminated with a resistor ($110\ \Omega$, $\frac{1}{4}\text{ W}$).

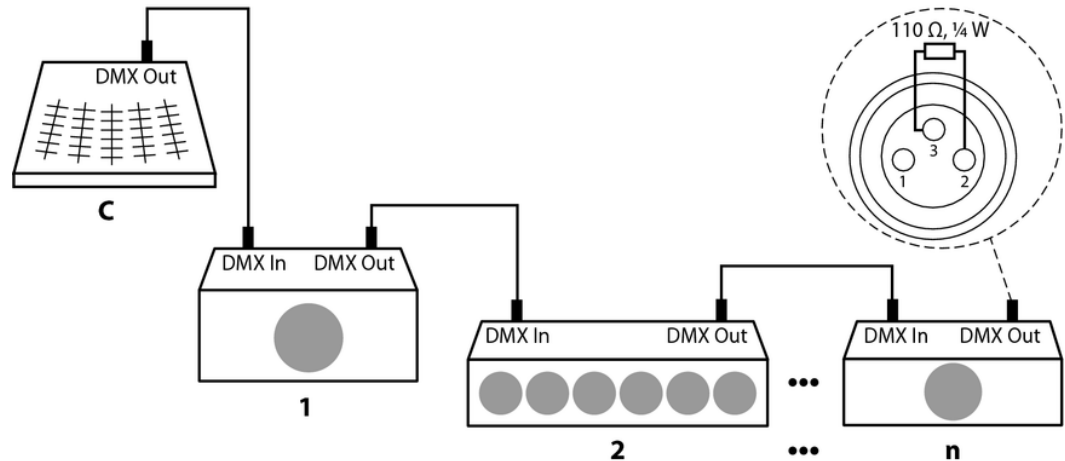

Connections in master/slave mode

When you configure a group of devices in master/slave mode, the first unit will control the other units for an automatic, sound-activated, synchronized show. This function is ideal when you want to start a show immediately. Connect the DMX output of the master device to the DMX input of the first slave device. Then connect the DMX output of the first slave device to the DMX input of the second slave device and so on.

6 Connections and controls

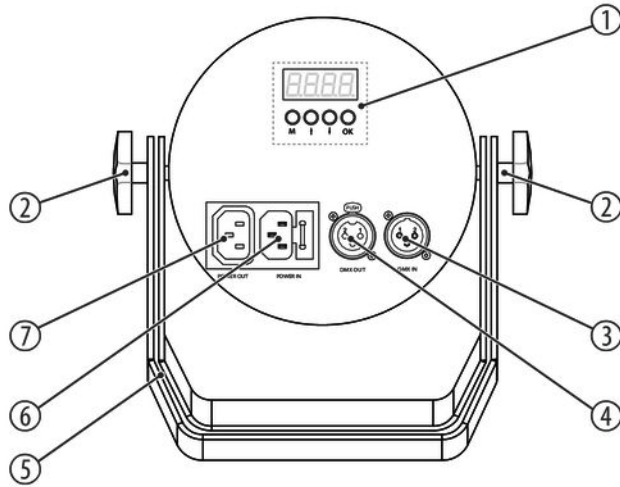

1	<p>Display</p> <p><i>[M]</i></p> <p>Activates the menu and selects the respective operating mode</p> <p>↑</p> <p>Increases the displayed value by one</p> <p>↓</p> <p>Decreases the displayed value by one</p> <p><i>[OK]</i></p> <p>Confirms the selection and saves the changes</p>
2	Locking screws for the brackets.
3	<p><i>[DMX In]</i></p> <p>DMX input</p>
4	<p><i>[DMX Out]</i></p> <p>DMX output</p>

5	Bracket for floor placement or hanging
6	<i>[Power In]</i> IEC chassis plug with fuse holder for the power connection
7	IEC chassis socket for the power supply of further devices

7 Operating

Connect the device to the power supply to start operation. After a few seconds, the display indicates that a reset is in progress. The device is then ready for use.

Press *[M]* to activate the menu and select an operating mode. Use \uparrow and \downarrow to change the respectively indicated value. Use *[OK]* to confirm the selection.

The display is turned off after an adjustable period of time without keystroke. The set values are retained even when the device is disconnected from the mains power supply.

Menu	Meaning
'd001...d512'	DMX address input
'7CH' – '4CH'	Selecting the DMX mode
'P001...P255'	Colour change programme, increasing speed
'L001...L255'	Colour change programme with smooth transition, increasing speed
'E001...E255'	Colour change programme (7 colours) with smooth transition, increasing speed

Menu	Meaning
'SOUD'	Colour change by sound control, light off with no signal input
'SUND'	Colour change by sound control, light permanently on
'r001...r255'	Intensity red (0 % to 100 %)
'G001...G255'	Intensity green (0 % to 100 %)
'b001...b255'	Intensity blue (0 % to 100 %)
'F001...F255'	Stroboscope effect for programme, sound mode and solid colours, increasing speed

7.1 Functions in 4-channel DMX mode

Channel	Value	Function
1	Strobe effect	
	0	Strobe off

Channel	Value	Function
	1...9	LEDs off
	10...255	Strobe effect, increasing speed
2	0...255	Intensity red (0 % to 100 %)
3	0...255	Intensity green (0 % to 100 %)
4	0...255	Intensity blue (0 % to 100 %)

7.2 Functions in 7-channel DMX mode

Channel	Value	Function
1	0...255	Intensity (0 % to 100 %)
2	Strobe effect	
	0	Strobe off

Channel	Value	Function
	1...9	LEDs off
	10...255	Strobe effect, increasing speed
3	Macro	
	0...50	No function
	51...100	Colour change programme
	101...150	Colour change with transition
	151...200	Colour change with Dimm effect
	201...255	Sound control
4	0...255	Macro speed increasing
5	0...255	Intensity red (0 % to 100 %)
6	0...255	Intensity green (0 % to 100 %)
7	0...255	Intensity blue (0 % to 100 %)

8 Technical specifications

Light source	18 × RGB, 1 W (6 × red, 6 × green, 6 × blue)	
Optical properties	Beam angle	15°
Control	DMX, buttons and display on the unit	
Number of DMX channels	4 or 7	
Input connections	Voltage supply	IEC panel plug
	DMX control	XLR chassis plug, 3-pin
Output connections	Voltage supply	IEC chassis socket
	DMX control	XLR chassis socket, 3-pin
Power consumption	max. 18 W	
Operating supply voltage	100 – 240 V ~ 50 / 60 Hz	
Fuse	5 mm × 20 mm, 2 A, 250 V, slow-blow	
Protection class	IP20	

RED Spot 18 RGB BLACK Spot 18 RGB

Technical specifications

Mounting options	hanging, standing	
Dimensions (W × H × D)	235 mm × 250 mm × 85 mm	
Weight	1.4 kg	
Ambient conditions	Temperature range	0 °C...40 °C
	Relative humidity	50 %, non-condensing

Further information

	RED Spot 18 RGB (item no. 463465)	BLACK Spot 18 RGB (item no. 465199)
Construction	Flat PAR	Flat PAR
Number of LEDs	18	18
LED type	Unicoloured	Unicoloured
Floor housing	No	No
Fanless	Yes	Yes
Wireless DMX	No	No
Remote control	Not possible	Not possible
Housing colour	Red	black

9 Plug and connection assignments

Introduction

This chapter will help you select the right cables and plugs to connect your valuable equipment so that a perfect light experience is guaranteed.

Please take our tips, because especially in 'Sound & Light' caution is indicated: Even if a plug fits into a socket, the result of an incorrect connection may be a destroyed DMX controller, a short circuit or 'just' a not working light show!

DMX connections

The unit offers a 3-pin XLR socket for DMX output and a 3-pin XLR plug for DMX input. Please refer to the drawing and table below for the pin assignment of a suitable XLR plug.



Pin	Configuration
1	Ground, shielding
2	Signal inverted (DMX-, 'cold signal')
3	Signal (DMX+, 'hot signal')

10 Troubleshooting



NOTICE!

Possible data transmission errors

For error-free operation make use of dedicated DMX cables and do not use ordinary microphone cables.

Never connect the DMX input or output to audio devices such as mixers or amplifiers.

In the following we list a few common problems that may occur during operation. We give you some suggestions for easy troubleshooting:

Symptom	Remedy
The unit does not work, no light, the fan does not run	Check the mains connection and the main fuse.
No response to the DMX controller	<ol style="list-style-type: none">1. Check the DMX connectors and cables for proper connection.2. Check the address settings and the DMX polarity.3. Try using another DMX controller.4. Check whether the DMX cables run near or parallel to high-voltage cables that may cause damage or interference to a DMX interface circuit.
The message 'Temp Error' is flashing in the display.	The unit is overheated. Switch it off and let it cool down.

If the procedures recommended above do not succeed, please contact our Service Center. You can find the contact information at www.thomann.de.

11 Cleaning

Optical lenses

Clean the optical lenses, that are accessible from the outside, regularly in order to optimize the light output. The frequency of cleaning depends on the operating environment: wet, smoky or particularly dirty surroundings can cause more accumulation of dirt on the optics of the device.

- Clean with a soft cloth using our lamp and lens cleaner (item no. 280122).
- Always dry the parts carefully.

12 Protecting the environment

Disposal of the packaging material



For the transport and protective packaging, environmentally friendly materials have been chosen that can be supplied to normal recycling.

Ensure that plastic bags, packaging, etc. are properly disposed of.

Do not just dispose of these materials with your normal household waste, but make sure that they are collected for recycling. Please follow the notes and markings on the packaging.

Disposal of your old device



This product is subject to the European Waste Electrical and Electronic Equipment Directive (WEEE) in its currently valid version. Do not dispose with your normal household waste.

Dispose of this device through an approved waste disposal firm or through your local waste facility. When discarding the device, comply with the rules and regulations that apply in your country. If in doubt, consult your local waste disposal facility.



