

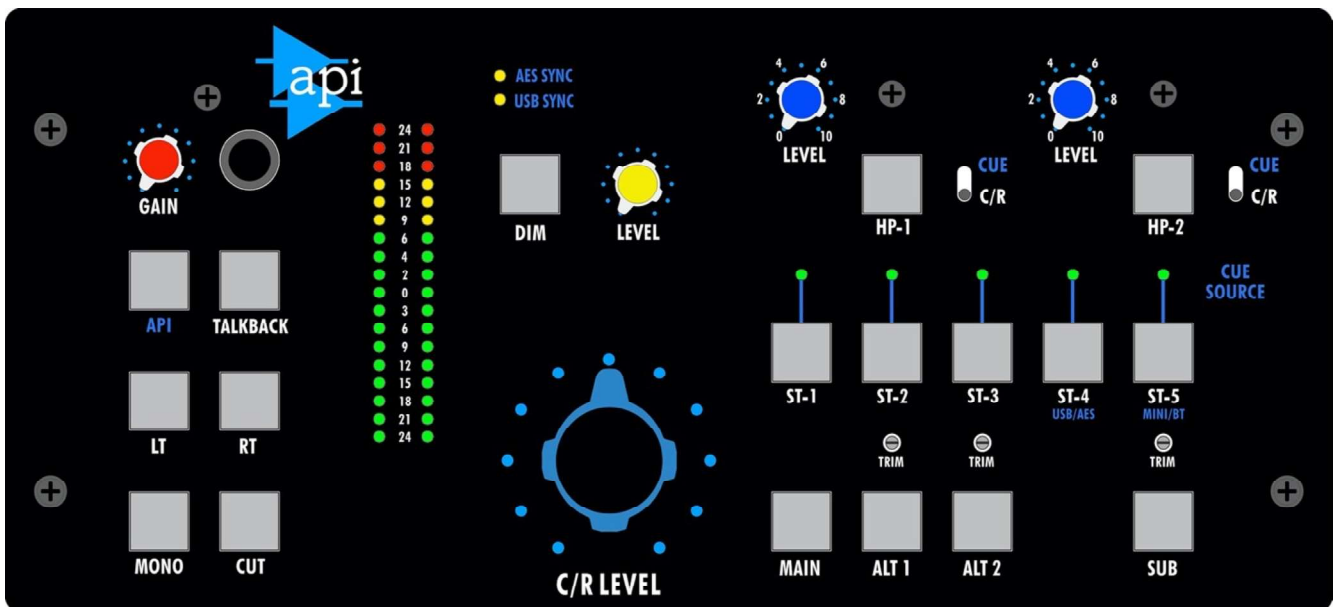

Automated Processes, Inc.

MC531 Monitor Controller



Operator's Manual

Written for Automated Processes, Incorporated
by Dan Pfeifer
Rev. 21-07-07

Table of Contents

<i>About This Manual</i>	3
<i>Important Safety Instructions</i>	1
<i>1.0 Introduction</i>	2
1.1 MC531 Overview	2
<i>2.0 Input Source Selectors</i>	4
2.1 Input Source Selection	4
2.1.1 Bluetooth Pairing	5
2.2 Input Source Meter	6
2.3 Input Source Connections	6
<i>3.0 Monitor Control Functions</i>	8
3.1 Monitor Controls	8
<i>4.0 Monitor Selectors</i>	10
4.1 Monitor Selector Controls	10
4.2 Subwoofer Output Linking	11
4.3 Monitor Output Connections	11
4.4 External Meter Connections	12
<i>5.0 Headphone Amplifiers</i>	13
5.1 Headphone Controls	13
5.2 Headphone Cue Function	14
5.3 Talkback to Headphones	14
5.4 Headphone Connections	14
<i>6.0 Rear Panel</i>	15
6.1 Input Source Connections	15
6.2 Monitor Output Connections	16
6.3 Headphone Connections	17
6.4 External Meter Connections	17
6.5 Power Supply Connection	18
<i>APPENDIX</i>	19
A1 MC531 Block Diagram	20
A2 Bluetooth Compliance	21
A3 API Limited Warranty and Service	22

About This Manual

This manual explains the operation and applications of the API MC531 monitor controller. Based on the monitor sections found in API consoles, the MC531 provides flexible, high-quality audio monitor control for most production applications, in a stand-alone configuration.

Legend:

- **UPPER-CASE BOLD = SWITCHES, BUTTONS, and POTS**
- UPPER-CASE = REAR PANEL CONNECTIONS

Manual Revision History: YY-MM-DD format

Original: 21-07-07

Important Safety Instructions

1. Please read these instructions
2. Keep this information in a safe place
3. Do not use this device near water
4. Clean only with a dry cloth
5. Do not block any ventilation openings
6. Do not install near any heat sources such as radiators, heat registers, stoves, or other devices that produce heat
7. Do not defeat the safety purpose of the polarized or grounding type AC plug
8. Protect the AC power cord from being walked on or pinched
9. Use only attachments/accessories specified by the manufacturer
10. Unplug this device during lightning storms or when unused for long periods of time
11. Refer all service to qualified personnel

ATTENTION: Exposure to extremely high noise levels may cause permanent hearing loss or damage. Individuals vary considerably in susceptibility to noise-induced hearing loss, but nearly everyone will lose some hearing if exposed to sufficiently intense noise (this may include music) for a period of time. Be safe.

WARNING – To reduce the risk of fire or electric shock, do not expose this apparatus to rain or moisture.

1.0 Introduction

Building on API's rich heritage of building high-quality recording consoles, we introduce the MC531 Monitor Controller. Based on the monitor sections found in API consoles, the MC531 is a flexible, high-quality, stereo audio monitor controller, in a stand-alone configuration. While designed to provide fully-featured monitor control for DAW workflows, the MC531 can integrate seamlessly into any audio production environment where sonic integrity, full functionality, and ease of use are paramount.

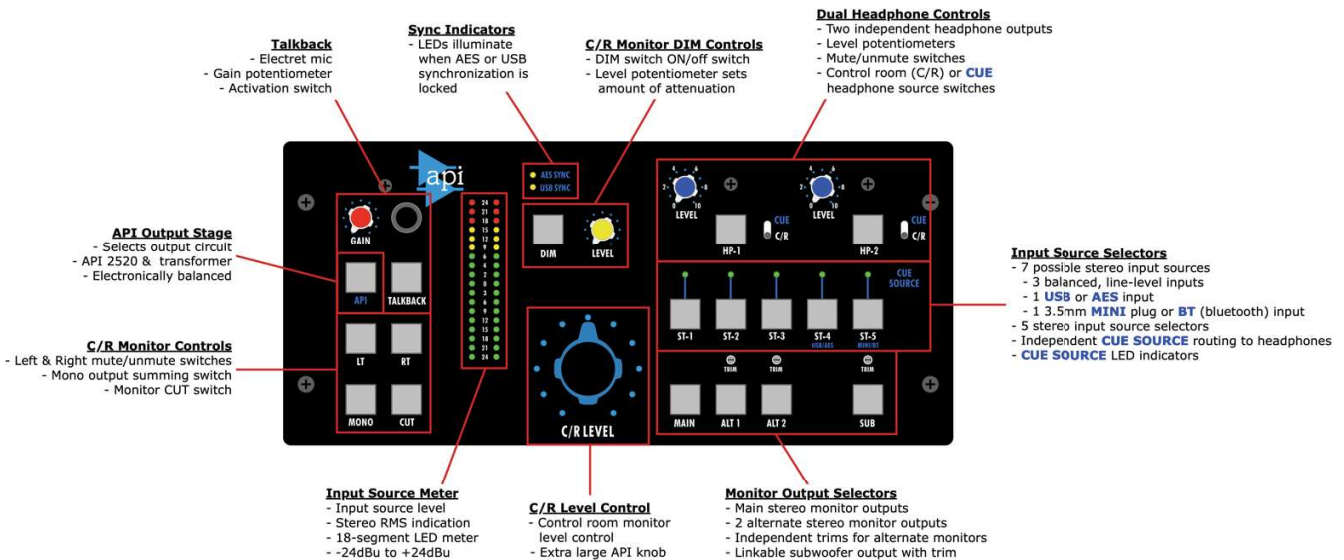

1.1 MC531 Overview

The MC531 is a comprehensive monitor controller that provides the following functions and features:

- Selectors for three sets of stereo monitors:
 - **MAIN**
 - **ALT 1** (alternate 1) with trim
 - **ALT 2** (alternate 2) with trim
- Assignable subwoofer integration:
 - Programmable link with the **MAIN, ALT 1, and/or ALT 2**
 - **SUB** ON/off button and trim
- Seven total stereo input sources:
 - Five stereo input source selectors
 - Three analog balanced, line-level input sources (**ST-1, ST-2, ST-3**)
 - Two digital input sources (**ST-4**)
 - **AES**
 - **USB** (no driver required)
 - Digital synchronization LED indicators
 - Two consumer input sources (**ST-5**)
 - 3.5mm **MINI** Plug (front and rear)
 - Bluetooth (**BT**)
 - High-resolution 18-segment LED input source meter
- Main output section:
 - **DIM** function with level control
 - Independent Left (**LT**) and Right (**RT**) mute buttons
 - **CUT** (mute) button
 - **MONO** summing button
 - **C/R LEVEL** volume potentiometer with large API knob
 - Selectable **API** 2520 op-amp/transformer or electronically balanced output stages
 - XLR output connectors

- Two independent headphone outputs:
 - ON/off button
 - **LEVEL** potentiometer
 - Choice of 2 sources:
 - Control Room (**C/R**) source
 - **CUE** source
- Talkback to headphones
 - Talkback electret microphone
 - Talkback **GAIN**
 - **TALKBACK** activation button

The MC531 is built to the same exacting build standards as API consoles.

2.0 Input Source Selectors



Five (5) input source selectors provide a choice of seven (7) different audio sources to feed the selected set of monitors. Each input source is buffered with an API 2510 op-amp. Only one source can be selected at a time.

The input source selectors are divided into three categories:

- Analog (**ST-1**, **ST-2**, **ST-3**)
- Digital (**ST-4**): **USB** or **AES**
- Consumer (**ST-5**): 3.5mm **MINI** plug or Bluetooth (**BT**)

2.1 Input Source Selection

The MC531 input source selectors function as follows:

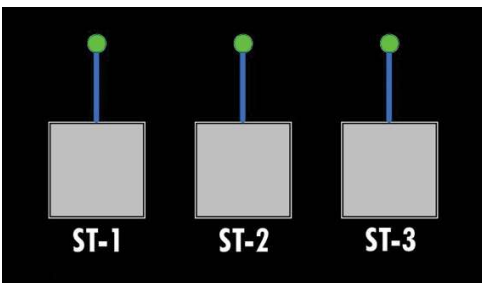

To select an analog input source, press the desired **ST-1**, **ST-2**, or **ST-3** source selector button:

- Balanced, low-impedance, line-level
- ¼" TRS jack pairs on rear panel interface
- The active analog source button will illuminate

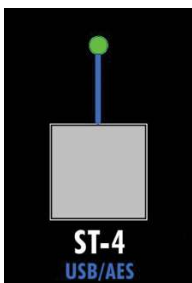

To select a digital **USB** or **AES** input source, press the **ST-4** source selector button:

- After **ST-4** is selected, press and hold to select between **USB** and **AES** inputs
 - **ST-4** will illuminate in blue when **USB** is selected as the active source
 - **ST-4** will illuminate in green when **AES** is selected as the active source
- Auto-sensing sample rate and bit depth
- Sample rates up to 192kHz
- No USB driver needed
- USB type-B **USB** rear panel interface
- 3-pin XLR **AES** rear panel interface



Yellow **AES SYNC** and **USB SYNC** LED indicators will illuminate when the MC531 is locked to valid **AES** and/or **USB** digital input sources.

NOTE: The USB interface uses a USB type-B connector on the rear panel. The USB interface relies on built-in drivers and is compatible with MAC OS and Windows10 or later.

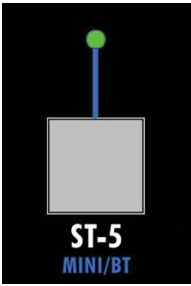

To select a consumer **MINI** plug or Bluetooth (**BT**) input source press the **ST-5** source selector button:

- After **ST-5** is selected, press and hold to select between the **MINI** plug and Bluetooth (**BT**) inputs
 - **ST-5** will illuminate in green when **MINI** is selected as the active source
 - **ST-5** will illuminate in blue when **BT** is selected as the active source
- 3.5mm MINI plug inputs on front and rear panels (*Use only one at a time!*)

The **MINI** plug input jacks are located below on the front of the MC531 below the control panel and as well as on the rear of the unit (not shown here).

The Bluetooth (**BT**) pairing button is also located on the front of the MC531 below the control panel.

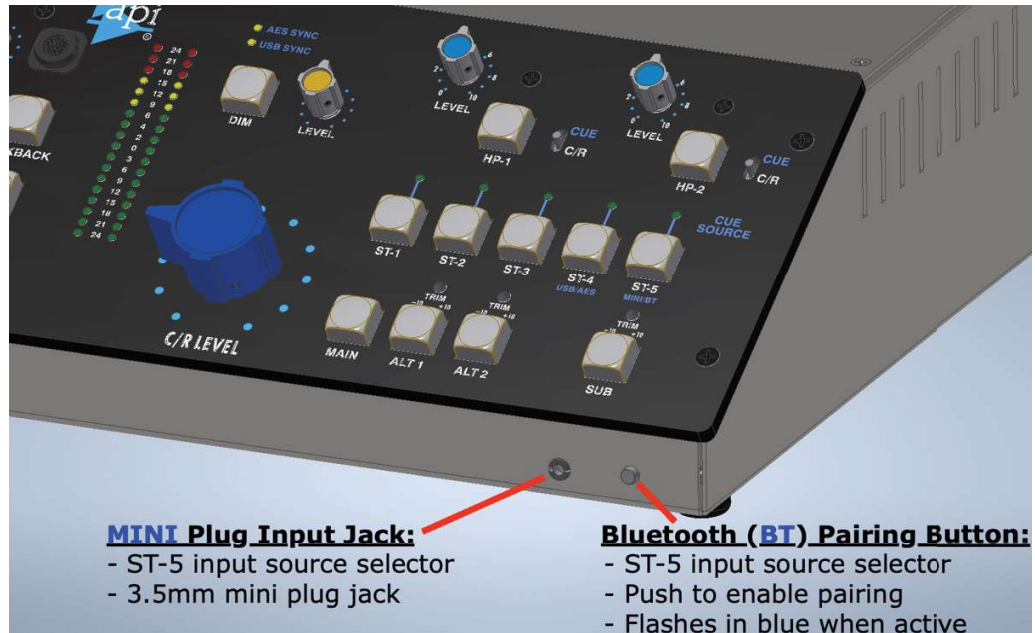

2.1.1 Bluetooth Pairing



To pair the MC531 with a Bluetooth audio source, perform the following steps:

1. Press the Bluetooth pairing button located below the control panel on the front of the MC531.
 - a. The button will start flashing in blue.
 - b. If ST-5 is active and Bluetooth (BT) is selected and the monitors are on, a pairing tone will be heard.
2. Enter the Bluetooth pairing mode on the device to be connected.
3. Select "API MC531" from the menu.
 - a. The device will connect to the MC531 and will indicate the connection.
 - b. The MC531 will produce another tone to confirm the pairing and the button will stop flashing.

Once pairing has been established, audio from the Bluetooth device will be available as an input source via the **ST-5** input selector. Bluetooth (**BT**) must be selected as the active input source for **ST-5**.

NOTE: When using an Android device, select the MC531 option with the headset icon.

NOTE: The MC531 can connect to multiple Bluetooth devices at the same time, but only one device can be heard at a time. The device that "play" was pressed on last will be the device heard.

2.2 Input Source Meter

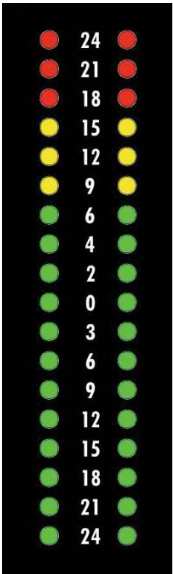

The level of the selected input source is displayed on a high-resolution RMS meter.

- -24dBu to +24dBu range
- 18-segment LED meter

NOTE: Stereo METER outputs connections are provided on the rear panel for interfacing an external meter.

2.3 Input Source Connections

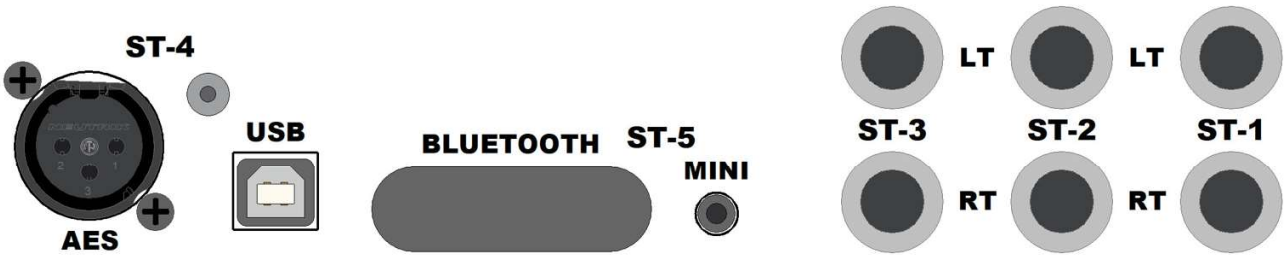

A complete set of input source connections are provided on the rear panel of the MC531. These connections are as follows:

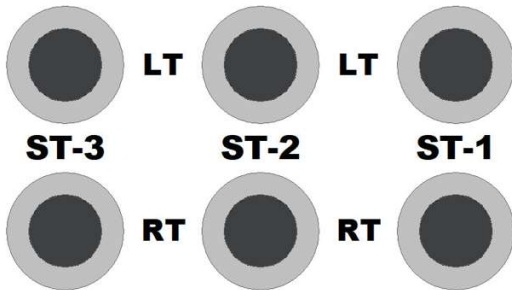

Analog Inputs: ST-1, ST-2, and ST-3

- LT and RT: Left and Right stereo pairs
- Balanced, low-impedance, line-level
- 1/4" TRS jacks

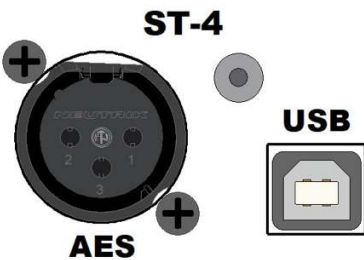

Digital Inputs: ST-4

- **AES:** 3-pin female XLR, AES3 standard
- **USB:** USB type-B connector

NOTE: The USB interface uses a USB type-B connector on the rear panel. The USB interface relies on built-in drivers and is compatible with MAC OS and Windows10 or later.

BLUETOOTH ST-5



MINI



Consumer Inputs: ST-5

- **BLUETOOTH:** Bluetooth antenna
- **MINI:** 3.5mm stereo (TRS) jack for MINI plug

3.0 Monitor Control Functions

The MC531 provides a comprehensive suite of monitor functions and controls.

- **C/R LEVEL** volume potentiometer
- **DIM** level and activation button
- Selectable **API** 2520 op-amp/transformer or electronically balanced output stage
- **MONO** summing button
- **LT** and **RT** mute buttons
- **CUT** (mute) button

3.1 Monitor Controls

The MC531 monitor controls function as follows:



C/R LEVEL (Control Room Level): Controls the output level for the selected monitor system.

- Volume control for the selected monitor system
- *The largest and most dangerous knob on the unit...*
Please use it wisely!



DIM (button): Reduces the output level of the selected monitors by routing the selected monitor source through the **DIM LEVEL** attenuation potentiometer.

- The amount of level reduction is set by the **DIM LEVEL** pot
- **DIM** is automatically engaged when the **TALKBACK** button is engaged
- Illuminates in yellow when engaged

DIM LEVEL (potentiometer): Sets the amount of attenuation applied to the selected monitor outputs when the **DIM** button is engaged.

- Only active when the **DIM** button is engaged
- 0dB to $-\infty$ dB range

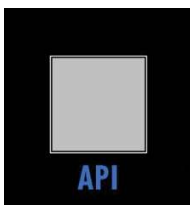

API (output stage): Routes monitor outputs through an API 2520 and custom transformer output stage when engaged

- Electronically balanced output stage when not engaged
- Illuminates in blue when engaged



LT and RT (Left and Right): Cuts the Left and/or Right feeds to the selected monitor system.

- ON/off (mute/unmute) switch for the selected monitor outputs
- Illuminates in red when engaged

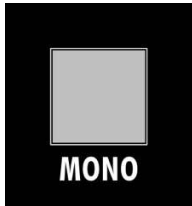

MONO: Sums the Left & Right monitor output feed to mono.

- Illuminates in red when engaged

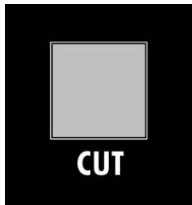

CUT (mute): Cuts the feed to the selected monitor system.

- ON/off (mute/unmute) switch for the selected monitor outputs
- Illuminates in red when engaged

4.0 Monitor Selectors

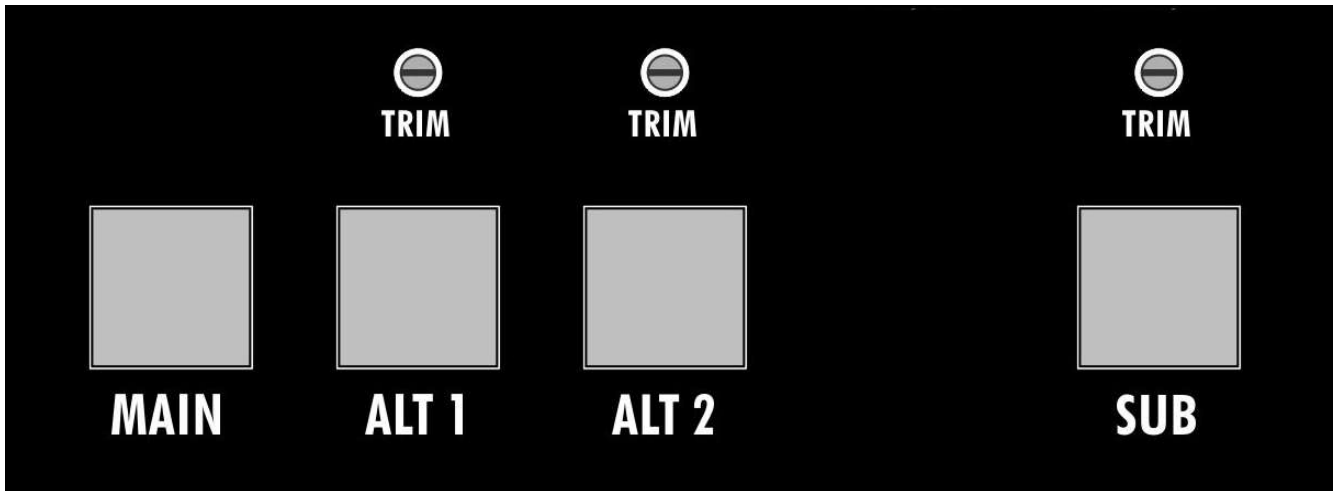

The MC531 supports three (3) sets of stereo audio monitors, plus a subwoofer with a programmable link to each stereo pair. Only one set of monitors can be selected at a time.

- **MAIN:** Main control room monitors
- **ALT 1:** Mid-field or near-field control room monitors
- **ALT 2:** Mid-field or near-field control room monitors

4.1 Monitor Selector Controls

The MC531 monitor selectors function as follows:

MAIN: Routes the selected input source to the MAIN monitor XLR outputs on the rear panel.

- Illuminates in blue when engaged

ALT 1: Routes the selected input source to the ALT 1 monitor XLR outputs on the rear panel.

- A -12dB to +6dB trim-pot sets the ALT 1 output level for matching with main system
- Illuminates in blue when engaged

ALT 2: Routes the selected input source to the ALT 2 monitor XLR outputs on the rear panel.

- A -12dB to +6dB trim-pot sets the ALT 2 output level for matching with active set of monitors
- Illuminates in blue when engaged

SUB (subwoofer): ON/off button for the subwoofer output

- Mono, unfiltered sum of selected Left and Right monitor outputs*
- Programmable link with MAIN, ALT 1, and ALT 2 monitor selections
- A -12dB to +6dB trim-pot sets the SUB output level for matching with active set of monitors
- If both **LT** and **RT** are engaged or if **CUT** is engaged, the **SUB** output is also muted
- Illuminates in blue when engaged

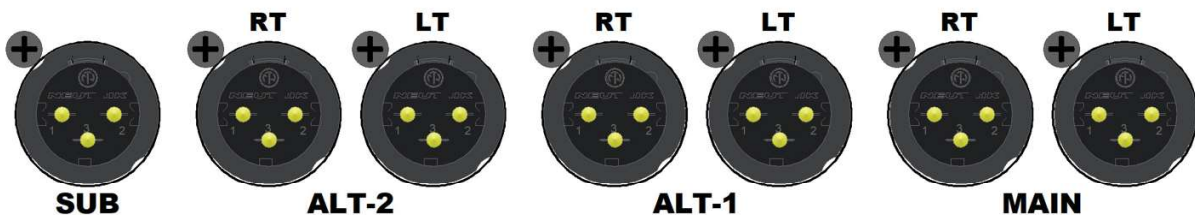

**IMPORTANT NOTE: The MC531 does not provide any bass management functions. When engaged, the SUB (subwoofer) output is unfiltered, full-bandwidth mono sum of the left and right monitor outputs. While this output is intended to feed a subwoofer, appropriate external filtration is needed for proper use (not supplied).*

4.2 Subwoofer Output Linking

Activation of the **SUB** (subwoofer) output can be linked to the **MAIN**, **ALT 1**, and/or **ALT 2** monitor selectors so it will automatically activate when linked sets of monitors are selected.

To link the **SUB** (subwoofer) output with a set of monitors, perform the following steps:

1. Press and hold the monitor selector (**MAIN**, **ALT 1**, or **ALT 2**) to be linked with the subwoofer.
 - a. The monitor selector will turn green
2. If the **SUB** button is green the link is established, press the **SUB** button to break the link.
3. If the **SUB** button is not illuminated in green, press the **SUB** button to establish the link.

Once the link has been established, the **SUB** (subwoofer) output will be activated when the linked set of monitor is selected.

4.3 Monitor Output Connections

A complete set of stereo monitor output connections are provided on the rear panel of the MC531. These connections are as follows:



MAIN LEFT & RIGHT OUTPUTS:

- LT and RT: Left and Right stereo pair
- Balanced, low-impedance, line-level
- 3-pin male XLRs
- Pin 1 = Ground, Pin 2 = +, Pin 3 = -



ALT 1 LEFT & RIGHT OUTPUTS:

- LT and RT: Left and Right stereo pair
- Balanced, low-impedance, line-level
- 3-pin male XLRs
- Pin 1 = Ground, Pin 2 = +, Pin 3 = -



ALT 2 LEFT & RIGHT OUTPUTS:

- LT and RT: Left and Right
- Balanced, low-impedance, line-level
- 3-pin male XLRs
- Pin 1 = Ground, Pin 2 = +, Pin 3 = -



SUB

SUB OUTPUT: Mono, unfiltered sum of selected Left and Right monitor outputs*

- Balanced, low-impedance, line-level
- 3-pin male XLR
- Pin 1 = Ground, Pin 2 = +, Pin 3 = -

**IMPORTANT NOTE: The MC531 does not provide any bass management functions. When engaged, the SUB (subwoofer) output is unfiltered, full-bandwidth mono sum of the left and right monitor outputs. While this output is intended to feed a subwoofer, appropriate external filtration is needed for proper use (not supplied).*

4.4 External Meter Connections



LT

METER

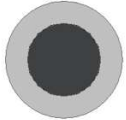

RT

The signal of the selected input source that is displayed on the high-resolution RMS meter is also available for use with external metering systems via the METER outputs.

- Unity gain selected input signal
- LT and RT: Left and Right stereo pair
- Balanced, low-impedance, line-level
- ¼" TRS jacks

5.0 Headphone Amplifiers

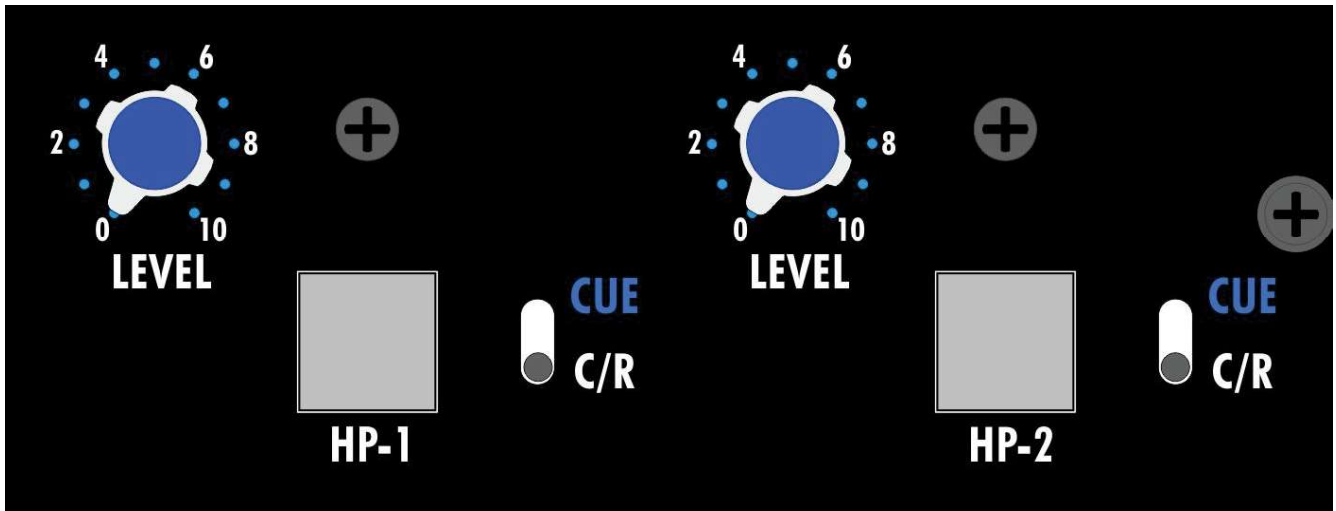

The MC531 is equipped with two independent stereo headphone amplifiers, HP-1 and HP-2. The amplifier circuit is the same as found in API consoles such as THE BOX, 1608, 1608-II, and 2448.

The MC531 headphone amplifiers are designed for use by the engineer, musicians, and others in the control room. Each headphone amplifier has the following features:

- ON/off switch
- Stereo volume potentiometer
- ¼" stereo headphone jack (located on rear panel)
- Source selector: Control room (**C/R**) or **CUE**
- Not affected by the control room CUT or monitor output selectors
- Talkback to headphones

The headphone amplifiers can be fed from two (2) primary sources, plus talkback when activated:

- **Control Room (C/R)**: Same feed as the monitor outputs
- **CUE**: Assignable input source

5.1 Headphone Controls

The MC531 headphone amplifier controls function as follows:



CUE – C/R (switch): Selects the source for the headphone amplifier.



LEVEL (potentiometer): Level control for the headphone amplifier.

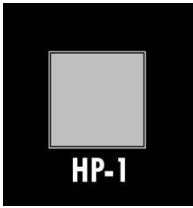

HP-1 or HP-2: ON/off switch for the headphone amplifiers.

- Illuminates in green when engaged

5.2 Headphone Cue Function

The headphone amplifiers can be fed from two (2) primary sources, plus talkback when activated:

- **Control Room (C/R):** Same feed as the monitor outputs
- **CUE:** Assignable input source

Any input source can be assigned to the **CUE** feed. Only one input source can be assigned as the **CUE SOURCE**. To assign an input source as the **CUE SOURCE**, perform the following steps:

1. Press and hold either the **HP-1** or **HP-2** buttons.
 - a. The **HP-1** or **HP-2** buttons will both "shimmer" quickly
2. While continuing to press a HP button, press an input source button to select it as the **CUE SOURCE**.
 - a. The green LED above the input source selector will illuminate indicating it has been assigned as the **CUE SOURCE**.
3. Release the **HP** button and the **CUE SOURCE** will be set.
4. Set the **CUE-C/R** switch to **CUE** to route the **CUE SOURCE** to either headphone amplifier.

The **CUE SOURCE** for ST-4 and ST-5 will follow the selected input for these sources (**USB** or **AES**, **MINI** or **BT**).

5.3 Talkback to Headphones

The MC531 is equipped with a talkback mic that can be added to the selected source for the headphone amplifiers.

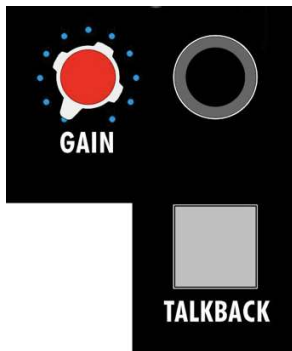

TALKBACK GAIN (potentiometer): Volume control for talkback to the headphone amplifiers

TALKBACK MICROPHONE: Electret condenser microphone

TALKBACK (button): Talkback activation button

- Adds the talkback mic to the selected source for the headphone amplifiers
- Momentary button (press and hold to use)
- Automatically engages the DIM function when engaged
- Illuminates in red when engaged

5.4 Headphone Connections

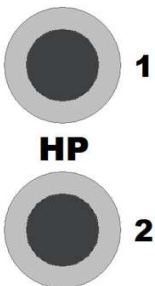

HP 1 and 2 (headphone): Stereo headphone amplifier output

- ¼" stereo TRS jacks

6.0 Rear Panel

The rear panel of the MC531 provide a complete set of connections including:

- **Input Source Connectors:** Analog (LT and RT), digital, and consumer
- **Monitor Output Connectors:** MAIN, ALT 1, ALT 2 (LT and RT)
- **Headphone Output Connectors:** HP-1, HP-2
- **Meter Output Connectors:** External meter LT and RT
- **Power Supply Connector:** DC power source and grounding

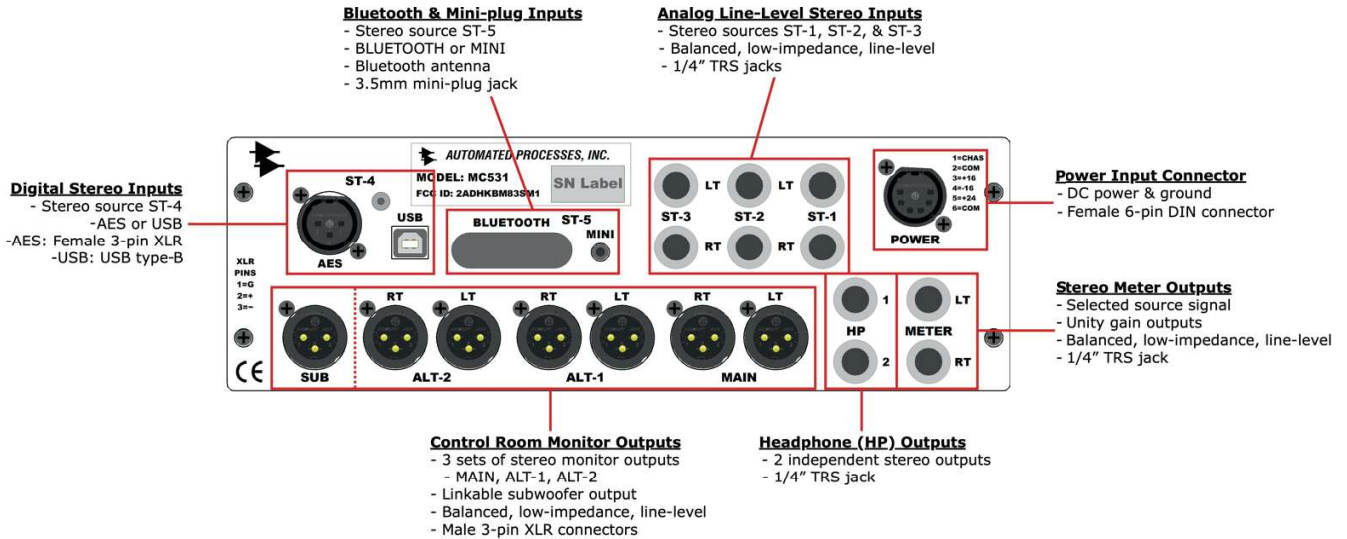

6.1 Input Source Connections

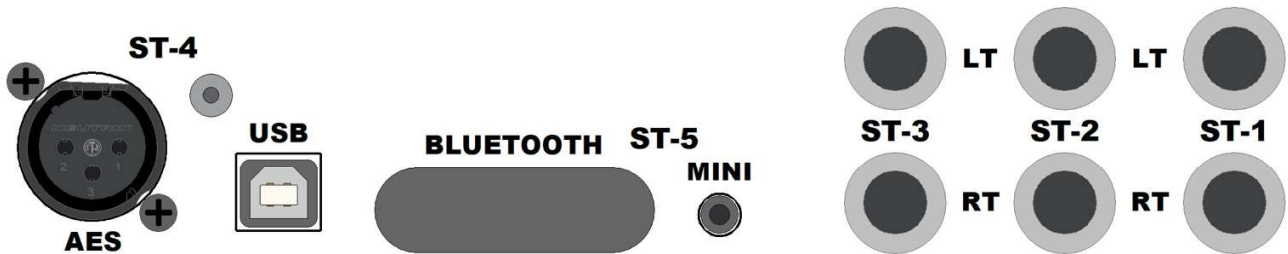

A complete set of input source connections are provided on the rear panel of the MC531. These connections are as follows:

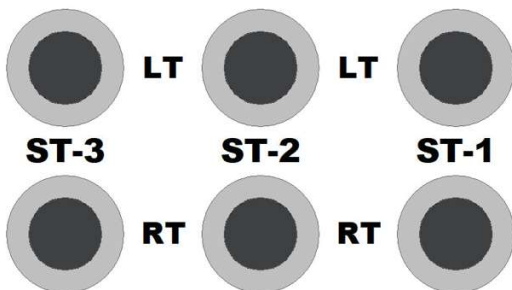

Analog Inputs: ST-1, ST-2, and ST-3

- LT and RT: Left and Right stereo pairs
- Balanced, low-impedance, line-level
- 1/4" TRS jacks



Digital Inputs: ST-4

- **AES:** 3-pin female XLR, AES3 standard
- **USB:** USB type-B connector

NOTE: The USB interface uses a USB type-B connector on the rear panel. The USB interface relies on built-in drivers and is compatible with MAC OS and Windows10 or later.



Consumer Inputs: ST-5

- **BLUETOOTH:** Bluetooth antenna
- **MINI:** 3.5mm stereo (TRS) jack for MINI plug

6.2 Monitor Output Connections



A complete set of stereo monitor output connections are provided on the rear panel of the MC531. These connections are as follows:

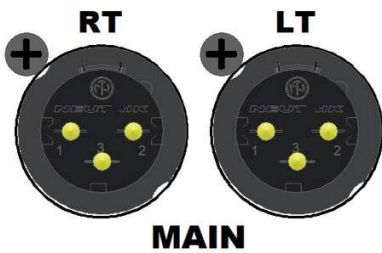

MAIN LEFT & RIGHT OUTPUTS:

- LT and RT: Left and Right stereo pair
- Balanced, low-impedance, line-level
- 3-pin male XLRs
- Pin 1 = Ground, Pin 2 = +, Pin 3 = -



ALT 1 LEFT & RIGHT OUTPUTS:

- LT and RT: Left and Right stereo pair
- Balanced, low-impedance, line-level
- 3-pin male XLRs
- Pin 1 = Ground, Pin 2 = +, Pin 3 = -



ALT 2 LEFT & RIGHT OUTPUTS:

- LT and RT: Left and Right stereo pair
- Balanced, low-impedance, line-level
- 3-pin male XLRs
- Pin 1 = Ground, Pin 2 = +, Pin 3 = -



SUB OUTPUT: Mono, unfiltered sum of selected Left and Right monitor outputs*

- Balanced, low-impedance, line-level
- 3-pin male XLR
- Pin 1 = Ground, Pin 2 = +, Pin 3 = -

**IMPORTANT NOTE: The MC531 does not provide any bass management functions. When engaged, the SUB (subwoofer) output is unfiltered, full-bandwidth mono sum of the left and right monitor outputs. While this output is intended to feed a subwoofer, appropriate external filtration is needed for proper use (not supplied).*

6.3 Headphone Connections

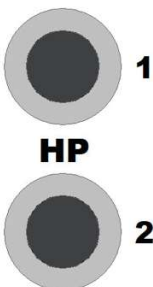

HP 1 and 2 (headphone): Stereo headphone amplifier output

- 1/4" stereo TRS jacks

6.4 External Meter Connections

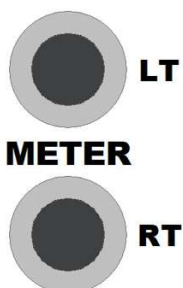

The signal of the selected input source that is displayed on the high-resolution RMS meter is also available for use with external metering systems via the METER outputs.

- Unity gain selected input signal
- LT and RT: Left and Right stereo pair
- Balanced, low-impedance, line-level
- 1/4" TRS jacks

6.5 Power Supply Connection



The MC531 is powered by an external DC power supply unit.

POWER: The main DC power supply unit connection is interfaced with a single, locking, 6-pin female DIN connector.

APPENDIX

A1 MC531 Block Diagram

A2 Bluetooth Compatibility

A3 API Limited Warranty and Service

A1 MC531 Block Diagram

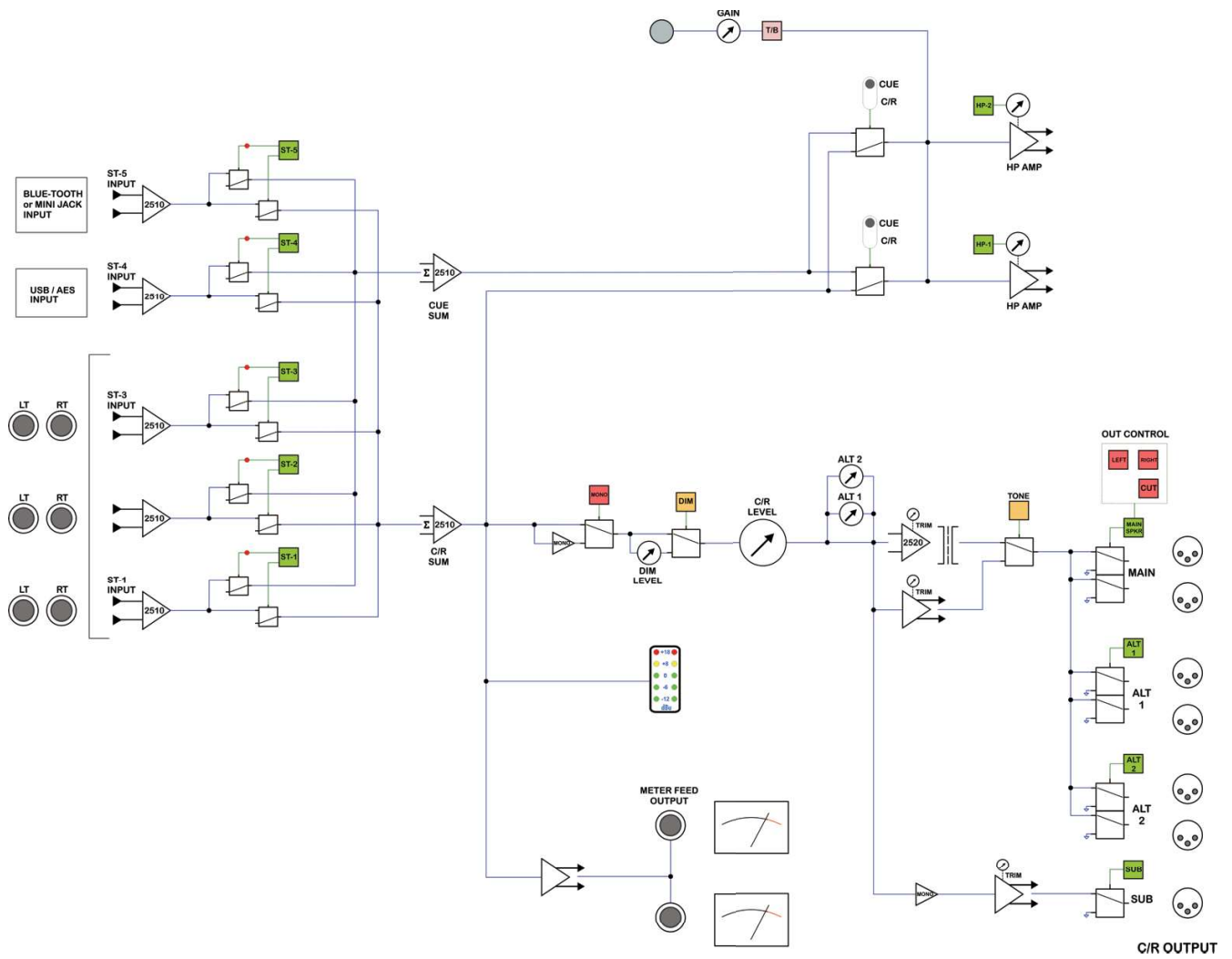

A2 Bluetooth Compliance

FCC ID: 2ADHKBM83SM1

This equipment has been tested and found to comply with the limits for a Class B digital device, pursuant to part 15 of the FCC Rules. These limits are designed to provide reasonable protection against harmful interference in a residential installation. This equipment generates, uses and can radiate radio frequency energy, and if not installed and used in accordance with the instructions, may cause harmful interference to radio communications. However, there is no guarantee that interference will not occur in a particular installation. If this equipment does cause harmful interference to radio or television reception, which can be determined by turning the equipment off and on, the user is encouraged to try to correct the interference by one or more of the following measures:

- Reorient or relocate the receiving antenna
- Increase the separation between the equipment and receiver
- Connect the equipment into an outlet on a circuit different from that to which the receiver is connected
- Consult the dealer or an experienced radio/TV technician for help



MSIP-R-R-API-MC531

해당 _무선설비는 _운용중 _전파혼신 _가능성이 _있음

A3 API Limited Warranty and Service

- a. **Warranty Information:** This product carries a one year labor and a five year parts warranty from date of purchase. API (Automated Processes, Incorporated) does not cover claims for damage due to alteration and/or abuse. This warranty is limited to failures during normal use, which are due to defects in material or workmanship. If any defects are found in the materials or workmanship, or if the product fails to function properly during the applicable warranty period, API, at its option, will repair or replace the product.
- b. **PLEASE NOTE:** The design or quality of any non-authorized third party service or vendor is beyond the control of API. Accordingly service or modification of any API unit except by an authorized API representative may VOID this warranty.
- c. API reserves the right to inspect any products that may be the subject of any warranty claims before repair or replacement is carried out. Final determination of warranty coverage lies solely with API.
- d. This warranty is extended to the original purchaser and to anyone who may subsequently purchase this product within the applicable warranty period. Proof of purchase may be required.
- e. For questions regarding operation, interfacing or service of your API product, please contact your API dealer from whom you purchased the unit. Many times your authorized API dealer is the fastest and most cost-effective way to maintain and service your product.
- f. You may also contact API's Service Department directly.
 - a. Call API at 301-776-7879 (ext. 252) between 8:30 AM and 5:00 PM Monday through Friday (Eastern Time) to get a Return Authorization (RA). Products returned without an RA number may not be accepted.
 - b. Pack the defective part by wrapping in plastic and cushioning material. Seal securely in an approved shipping container. If you do not have a sufficient shipping container, ask API for advice when calling for the RA number.
 - c. Include a note explaining the problem and conditions of the service request. Include your complete return address (no P.O. Boxes, please).
 - d. Ship the product freight prepaid to:

API
8301 Patuxent Range Road
Jessup, MD 20794

IMPORTANT: Be sure the RA number is plainly written on the shipping carton.

- g. This is your sole warranty. API does not authorize any third party, including any dealer or sales representative, to assume liability on behalf of API or to make any warranty for API.
- h. THE WARRANTY GIVEN ON THIS PAGE IS THE SOLE WARRANTY GIVEN BY API AND IS IN LIEU OF ALL OTHER WARRANTIES, EXPRESS AND IMPLIED, INCLUDING THE WARRANTIES OF MERCHANTABILITY AND FITNESS FOR A PARTICULAR PURPOSE. THE WARRANTY GIVEN ON THIS PAGE SHALL BE STRICTLY LIMITED IN DURATION TO FIVE (5) YEARS FROM THE DATE OF THE ORIGINAL PURCHASE FROM API OR AN AUTHORIZED API DEALER. UPON EXPIRATION OF THE APPLICABLE WARRANTY PERIOD API SHALL HAVE NO FURTHER WARRANTY OBLIGATION OF ANY KIND. API SHALL NOT BE LIABLE FOR ANY INCIDENTAL, SPECIAL, OR CONSEQUENTIAL DAMAGES THAT MAY RESULT FROM ANY DEFECT IN THE API PRODUCT OR ANY WARRANTY CLAIM.

This warranty provides specific legal rights and you may have other rights, which vary from state to state.



Automated Processes, Inc.

8301 Patuxent Range Road
Jessup, MD 20794 USA
301-776-7879
<http://www.apiaudio.com>