



TA 1050 MK-X, TA 1400 MK-X,
TA 2400 MK-X

Power Amplifier

Thomann GmbH

Hans-Thomann-Straße 1

96138 Burgebrach

Germany

Telephone: +49 (0) 9546 9223-0

Internet: www.thomann.de

12.03.2024, ID: 156555, 156556, 156557 (V4)

Table of contents

1	General information.....	5
	1.1 Symbols and signal words.....	5
2	Safety instructions.....	7
3	Features.....	10
4	Installation and starting up.....	11
5	Connections and controls.....	12
6	Technical specifications.....	15
7	Plug and connection assignment.....	23
8	Cleaning.....	27
9	Protecting the environment.....	28





1 General information

This document contains important instructions for the safe operation of the product. Read and follow the safety instructions and all other instructions. Keep the document for future reference. Make sure that it is available to all those using the product. If you sell the product to another user, be sure that they also receive this document.

Our products and documentation are subject to a process of continuous development. They are therefore subject to change. Please refer to the latest version of the documentation, which is ready for download under www.thomann.de.

1.1 Symbols and signal words

In this section you will find an overview of the meaning of symbols and signal words that are used in this document.

Signal word	Meaning
DANGER!	This combination of symbol and signal word indicates an immediate dangerous situation that will result in death or serious injury if it is not avoided.
WARNING!	This combination of symbol and signal word indicates a possible dangerous situation that can result in death or serious injury if it is not avoided.
CAUTION!	This combination of symbol and signal word indicates a possible dangerous situation that can result in minor injury if it is not avoided.
NOTICE!	This combination of symbol and signal word indicates a possible dangerous situation that can result in material and environmental damage if it is not avoided.
Warning signs	Type of danger
	Warning – high-voltage.
	Warning – danger zone.

2 Safety instructions

Intended use

This device amplifies electric audio frequency signals to operate passive speakers. Use the device only as described in this user manual. Any other use or use under other operating conditions is considered to be improper and may result in personal injury or property damage. No liability will be assumed for damages resulting from improper use.

This device may be used only by persons with sufficient physical, sensorial, and intellectual abilities and having corresponding knowledge and experience. Other persons may use this device only if they are supervised or instructed by a person who is responsible for their safety.

Safety



DANGER!

Risk of injury and choking hazard for children!

Children can suffocate on packaging material and small parts. Children can injure themselves when handling the device. Never allow children to play with the packaging material and the device. Always store packaging material out of the reach of babies and small children. Always dispose of packaging material properly when it is not in use. Never allow children to use the device without supervision. Keep small parts away from children and make sure that the device does not shed any small parts (such knobs) that children could play with.



DANGER!

Danger to life due to electric current!

Within the device there are areas where high voltages may be present. Never remove any covers. There are no user-serviceable parts inside. Do not use the device when covers, safety equipment or optical components are missing or damaged.



DANGER!

Danger to life due to electric current!

A short circuit could lead to a fire hazard and risk of death. Always use proper ready-made insulated triple-core mains cable with a safety plug. Do not modify the mains cable or the plug. In case of isolation damage, disconnect immediately the power supply and arrange repair. If in doubt, seek advice from a qualified electrician.



WARNING!

Possible hearing damage due to operating the device at a high volume!

The device can produce volume levels that, when operated at a high volume, may cause temporary or permanent hearing impairment. Over an extended period of time, even levels that seem to be uncritical can cause hearing damage. Avoid operating the device at excessively high volumes over an extended period of time. Decrease the volume level immediately if you experience ringing in your ears or hearing impairment. If this is not possible, keep a greater distance or use adequate ear-muffs.



CAUTION!

Risk of injury due to heavy weight!

The device is heavy. Lifting and dropping it during transport and installation can cause injuries. Make sure at least two people work together when transporting and installing the device.



NOTICE!

Risk of fire due to covered vents and neighbouring heat sources!

If the vents of the device are covered or the device is operated in the immediate vicinity of other heat sources, the device can over-heat and burst into flames. Never cover the device or the vents. Do not install the device in the immediate vicinity of other heat sources. Never operate the device in the immediate vicinity of naked flames.

**NOTICE!****Damage to the device if operated in unsuitable ambient conditions!**

The device can be damaged if it is operated in unsuitable ambient conditions. Only operate the device indoors within the ambient conditions specified in the "Technical specifications" chapter of this user manual. Avoid operating it in environments with direct sunlight, heavy dirt and strong vibrations. Avoid operating it in environments with strong temperature fluctuations. If temperature fluctuations cannot be avoided (for example after transport in low outside temperatures), do not switch on the device immediately. Never subject the device to liquids or moisture. Never move the device to another location while it is in operation. In environments with increased dirt levels (for example due to dust, smoke, nicotine or mist): Have the device cleaned by qualified specialists at regular intervals to prevent damage due to overheating and other malfunctions.

**NOTICE!****Damage to the device due to high voltages!**

The device can be damaged if it is operated with the incorrect voltage or if high voltage peaks occur. In the worst case, excess voltages can also cause a risk of injury and fires. Make sure that the voltage specification on the device matches the local power grid before plugging in the device. Only operate the device from professionally installed mains sockets that are protected by a residual current circuit breaker (FI). As a precaution, disconnect the device from the power grid when storms are approaching or if the device will not be used for a longer period.

**NOTICE!****Interference with nearby electrical devices due to magnetic fields!**

The device generates strong magnetic fields that can interfere with the function of poorly shielded devices. The magnetic fields are strongest directly above and below the Power Amplifier. You should therefore never place sensitive devices such as pre-amplifiers, radio transmission systems, or tape decks directly above or below the Power Amplifier. When placing the Power Amplifier in a rack, you should place it at the bottom thereof, and place any other equipment at the top of the rack.

**NOTICE!****Risk of fire due to installation of a wrong fuse!**

Using fuses of a different type than compatible with the device may cause a fire and seriously damage the device. Only use fuses of the same type. Observe the labelling on the device casing and the information in the "Technical data" chapter.

3 Features

- Inputs
 - 2 × XLR
 - 2 × 6.35-mm jack
- Outputs
 - 2 × Speaker Twist (lockable)
 - 2 × screw terminal
- Protective circuits
 - Audio limiter
 - Thermal protection
 - Short circuit protection
 - DC voltage protection
 - Overcurrent protection
 - Infrasound protection
- Cooling via integrated two-stage fans
- Suitable for 19-inch racks (2 RU, installation depth 44 cm)

For device-specific features see [🔗 Chapter 6 'Technical specifications'](#) on page 15.

4 Installation and starting up

Unpack and check carefully there is no transportation damage before using the unit. Keep the equipment packaging. To fully protect the product against vibration, dust and moisture during transportation or storage use the original packaging or your own packaging material suitable for transport or storage, respectively.

Create all connections while the device is off. Use the shortest possible high-quality cables for all connections. Take care when running the cables to prevent tripping hazards.

5 Connections and controls

Front panel

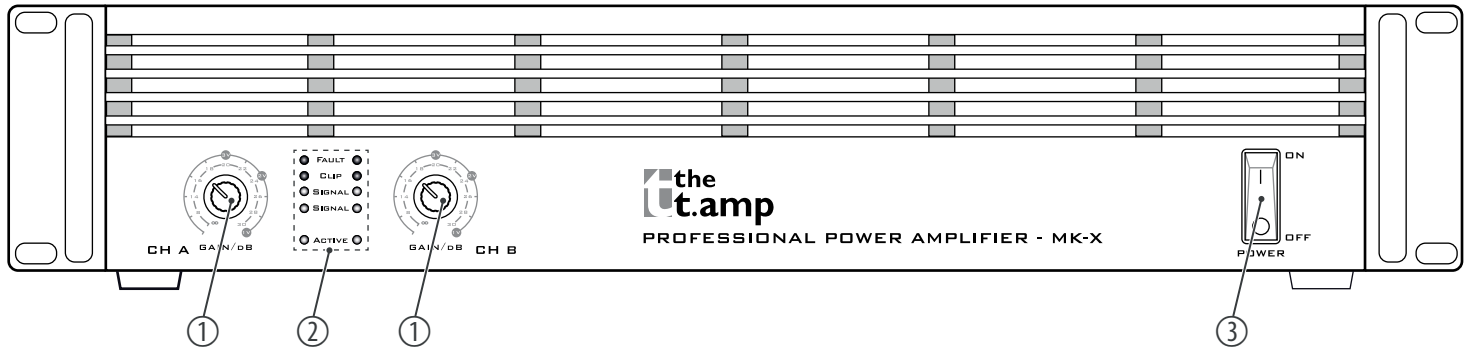

- | | |
|---|---|
| 1 | [CH-A] / [CH-B] Input gain controls for channels A and B |
| 2 | LED indicators [CH-A] / [CH-B] These LEDs indicate the ready status of the device ([Power]), the input signal level ([Signal]), channel overdrive ([Clip]) and a fault condition ([Fault]). |
| 3 | [POWER] Main switch for turning the device on and off |



The [Power] LED is permanently lit during operation. The [Signal] LEDs respond to the input signal. If any of these LEDs light up without an input signal present, disconnect the speakers from the power amplifier and turn the input gain controls of channels A and B down to minimum. If the LEDs will still light, the device must be checked by an authorized service workshop.

Rear panel

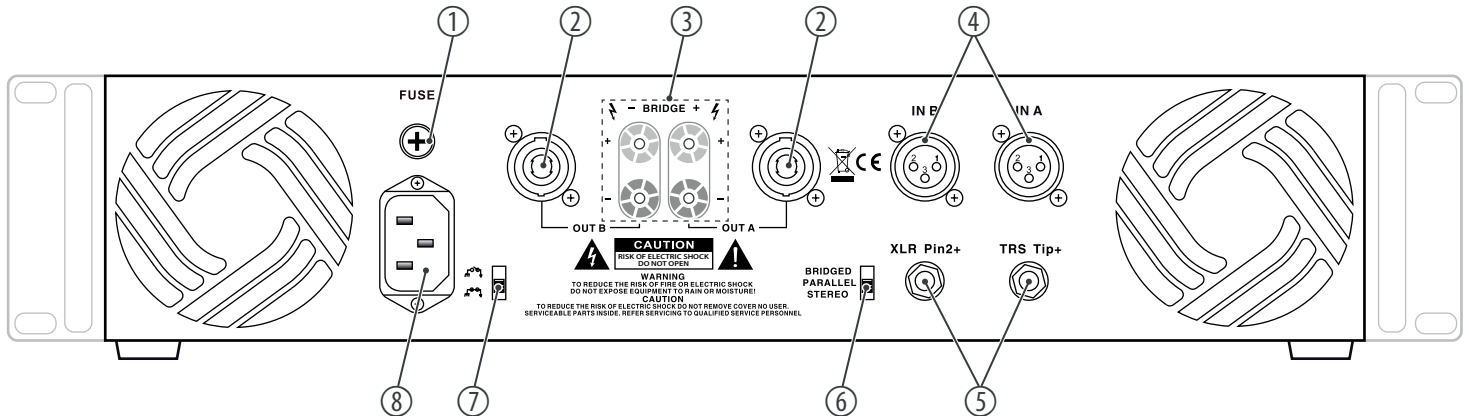

1	Fuse holder
2	<i>[OUT A] / [OUT B]</i> Signal outputs, designed as lockable NL4 panel sockets for connecting speakers
3	<i>[OUT A] / [OUT B]</i> Signal outputs, designed as screw terminals (+/-) for connecting speakers
4	<i>[IN A] / [IN B]</i> Signal inputs, designed as XLR panel sockets
5	<i>[IN A] / [IN B]</i> Signal inputs, designed as 6.35-mm jack sockets
6	<i>[STEREO/PARALLEL/BRIDGED]</i> Switch for operating modes “STEREO” (channels operate independently of each other), “PARALLEL” (inputs of the channels are combined. Input A is output on output A and output B.) and “BRIDGED” (channels are interconnected to form one channel with double output).
7	<i>[Lift/Ground]</i> switch Use the ground/lift switch to separate the connection between the earth pin of the device and the unit's signal ground to prevent ground loops: <ul style="list-style-type: none">■ “Lift” position (not pressed): no connection■ “Ground” position (pressed): earth pin and signal ground are electrically connected
8	Rubber panel plug for the power supply

6 Technical specifications

TA 1050 MK-X

Amplifier class	H	
Input impedance	20 k Ω (balanced) 10 k Ω (unbalanced)	
Output power	RMS 8 Ω , stereo	2 \times 380 W
	RMS 4 Ω , stereo	2 \times 520 W
	RMS 8 Ω , mono "bridged"	1050 W
Slew rate	40 V/ μ s	
Common mode rejection	> 60 dB (1 kHz)	
IMD-SMPTE (60 Hz, 7 kHz)	<0.01% / 400 W	
Crosstalk	< 60 dB	
Frequency response	20 Hz ... 20 kHz (+ 0.1 ... -3 dB, 1 W, 8 Ω)	
Signal-to-noise ratio	103 dB	
Total harmonic distortion (THD) 4 Ω at 1 kHz	<0.05% / 620 W	

Technical specifications

Damping factor (8 Ω, 1 kHz)	300:1			
Sensitivity	0.775 V at rated power (8 Ω)			
Gain	34 dB			
Cooling	2 × 2-speed DC fans			
Power consumption	Load	1/8 nominal power	1/3 nominal power	1/1 nominal power
	(2 ×) 8 Ω	450 W / 2.9 A	690 W / 4.2 A	1190 W / 6.8 A
	(2 ×) 4 Ω	735 W / 4.4 A	1150 W / 6.6 A	1980 W / 10.6 A
Supply voltage	230 V ~ 50 Hz			
Fuse	5 mm × 20 mm, 15 A, 250 V, fast blow			
Dimensions (W × H × D)	483 mm × 103 mm × 475 mm			
Weight	16.4 kg			
Ambient conditions	Temperature range	0 °C...40 °C		
	Relative humidity	50%, non-condensing		

TA 1400 MK-X

Amplifier class	H	
Input impedance	20 k Ω (balanced) 10 k Ω (unbalanced)	
Output power	RMS 8 Ω , stereo	2 \times 570 W
	RMS 4 Ω , stereo	2 \times 850 W
	RMS 8 Ω , mono "bridged"	1600 W
Slew rate	40 V/ μ s	
Common mode rejection	> 60 dB (1 kHz)	
IMD-SMPTE (60 Hz, 7 kHz)	<0.01% / 570 W	
Crosstalk	< 60 dB	
Frequency response	20 Hz ... 20 kHz (+ 0.1 ... -3 dB, 1 W, 8 Ω)	
Signal-to-noise ratio	103 dB	
Total harmonic distortion (THD) 4 Ω at 1 kHz	<0.05% / 850 W	
Damping factor (8 Ω , 1 kHz)	350:1	
Sensitivity	0.775 V at rated power (8 Ω)	

Technical specifications

Gain	36.9 dB			
Cooling	2 × 2-speed DC fans			
Power consumption	Load	1/8 nominal power	1/3 nominal power	1/1 nominal power
	(2 ×) 8 Ω	380 W / 2.4 A	985 W / 5.8 A	1650 W / 9.3 A
	(2 ×) 4 Ω	665 W / 3.9 A	1730 W / 9.9 A	2650 W / 14.0 A
Supply voltage	230 V ~ 50 Hz			
Fuse	5 mm × 20 mm, 15 A, 250 V, fast blow			
Dimensions (W × H × D)	483 mm × 103 mm × 475 mm			
Weight	17.5 kg			
Ambient conditions	Temperature range	0 °C...40 °C		
	Relative humidity	50%, non-condensing		

TA 2400 MK-X

Amplifier class	H	
Input impedance	20 k Ω (balanced) 10 k Ω (unbalanced)	
Output power	RMS 8 Ω , stereo	2 \times 760 W
	RMS 4 Ω , stereo	2 \times 1200 W
	RMS 8 Ω , mono "bridged"	2300 W
Slew rate	60 V/ μ s	
Common mode rejection	> 60 dB (1 kHz)	
IMD-SMPTE (60 Hz, 7 kHz)	<0.01% / 760 W	
Crosstalk	< 60 dB	
Frequency response	20 Hz ... 20 kHz (+ 0.1 ... -3 dB, 1 W, 8 Ω)	
Signal-to-noise ratio	103 dB	
Total harmonic distortion (THD) 4 Ω at 1 kHz	<0.05% / 1200 W	
Damping factor (8 Ω , 1 kHz)	500:1	
Sensitivity	0.775 V at rated power (8 Ω)	

Technical specifications

Gain	39.2 dB			
Cooling	2 × 2-speed DC fans			
Power consumption	Load	1/8 nominal power	1/3 nominal power	1/1 nominal power
	(2 ×) 8 Ω	443 W / 2.8 A	1080 W / 6.6 A	2180 W / 12.2 A
	(2 ×) 4 Ω	790 W / 4.8 A	2004 W / 10.3 A	3600 W / 18.9 A
Supply voltage	230 V ~ 50 Hz			
Fuse	5 mm × 20 mm, 20 A, 250 V, fast blow			
Dimensions (W × H × D)	483 mm × 103 mm × 475 mm			
Weight	19.7 kg			
Ambient conditions	Temperature range	0 °C...40 °C		
	Relative humidity	50%, non-condensing		

Further information

Channels	2
19-inch rack installation height	2 RU
2 Ω stable	No
DSP / frequency	No
Convection cooling	No
Protection circuits (DC voltage protection, overtemperature protection, short-circuit protection, infrasound protection, overcurrent protection)	Yes

Block diagram

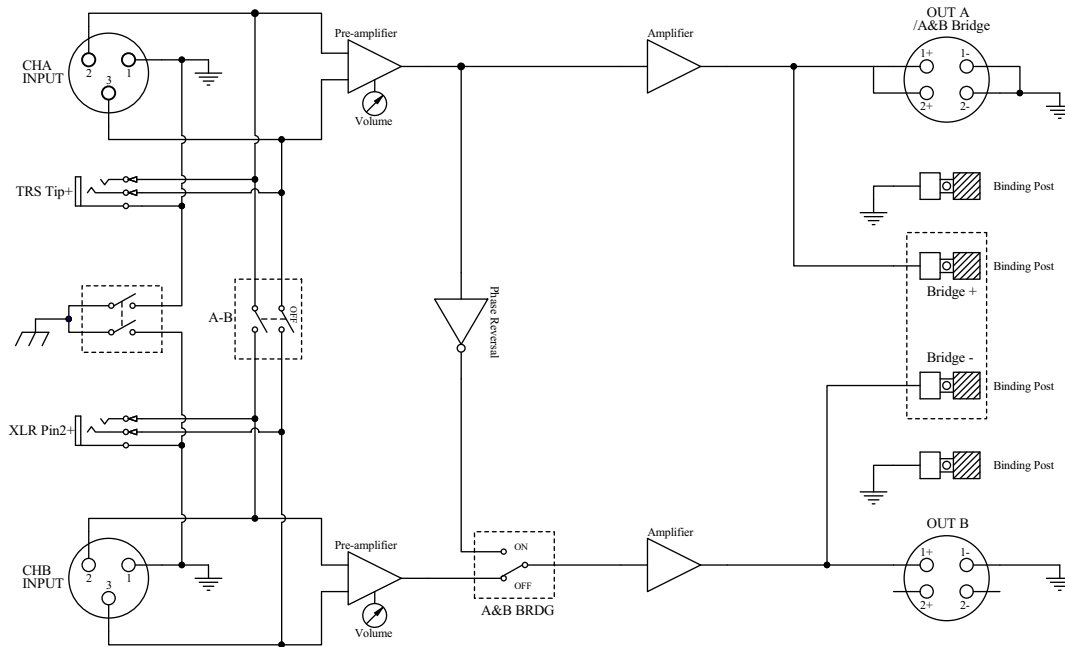

7 Plug and connection assignment

Introduction

This chapter will help you select the right cables and plugs to connect your valuable equipment in such a way that a perfect sound experience is ensured.

Please note these advices, because especially in 'Sound & Light' caution is indicated: Even if a plug fits into the socket, an incorrect connection may result in a destroyed power amp, a short circuit or 'just' in poor transmission quality!

Balanced and unbalanced transmission

Unbalanced transmission is mainly used in semi-professional environment and in hifi use. Instrument cables with two conductors (one core plus shielding) are typical representatives of the unbalanced transmission. One conductor is ground and shielding while the signal is transmitted through the core.

Unbalanced transmission is susceptible to electromagnetic interference, especially at low levels, such as microphone signals and when using long cables.

In a professional environment, therefore, the balanced transmission is preferred, because this enables an undisturbed transmission of signals over long distances. In addition to the conductors 'Ground' and 'Signal', in a balanced transmission a second core is added. This also transfers the signal, but phase-shifted by 180°.

Since the interference affects both cores equally, by subtracting the phase-shifted signals, the interfering signal is completely neutralized. The result is a pure signal without any noise interference.

XLR plug (balanced)

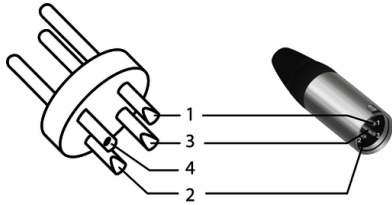

1	Ground, shielding
2	Signal (in phase, +)
3	Signal (out of phase, -)
4	Shielding on plug housing (option)

XLR plug (unbalanced)

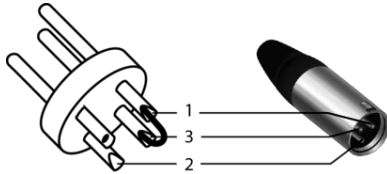

1	Ground, shielding
2	Signal
3	Bridged to pin 1

Speaker Twist chassis connector

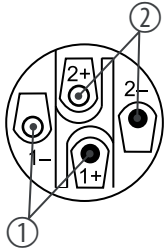

1, +	Signal 1 (in phase)
1, -	Signal 1 (out of phase)
2, +	Signal 2 (in phase)
2, -	Signal 2 (out of phase)

1/4" TS phone plug (mono, unbalanced)



1	Signal
2	Ground, shielding

1/4" TRS phone plug (mono, balanced)



1	Signal (in phase, +)
2	Signal (out of phase, -)
3	Ground

1/4" TRS phone plug (stereo, unbalanced)



1	Signal (left)
2	Signal (right)
3	Ground

8 Cleaning

Fan grids

The fan grids of the device must be cleaned of any contamination, such as dust, etc. on a regular basis. Before cleaning, switch off the device and disconnect mains-operated devices from the mains. Only use pH-neutral, solvent-free and non-abrasive cleaning agents. Clean the unit with a slightly damp lint-free cloth.

9 Protecting the environment

Disposal of the packing material

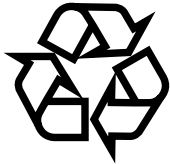

Environmentally friendly materials have been chosen for the packaging. These materials can be sent for normal recycling. Ensure that plastic bags, packaging, etc. are disposed of in the proper manner.

Do not dispose of these materials with your normal household waste, but make sure that they are collected for recycling. Please follow the instructions and markings on the packaging.



Observe the disposal note regarding documentation in France.

Disposal of your old device

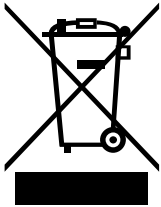

This product is subject to the European Waste Electrical and Electronic Equipment Directive (WEEE) as amended.

Do not dispose of your old device with your normal household waste; instead, deliver it for controlled disposal by an approved waste disposal firm or through your local waste facility. When disposing of the device, comply with the rules and regulations that apply in your country. If in doubt, consult your local waste management facility. Proper disposal protects the environment as well as the health of your fellow human beings.

Also note that waste avoidance is a valuable contribution to environmental protection. Repairing a device or passing it on to another user is an ecologically valuable alternative to disposal.

You can return your old device to Thomann GmbH at no charge. Check the current conditions on www.thomann.de.

If your old device contains personal data, delete those data before disposing of it.

