

**the**  
**box** **pro**

Achat 112 MA  
Achat 112 MA WH  
active speaker

Musikhaus Thomann  
Thomann GmbH  
Hans-Thomann-Straße 1  
96138 Burgebrach  
Germany  
Telephone: +49 (0) 9546 9223-0  
E-mail: [info@thomann.de](mailto:info@thomann.de)  
Internet: [www.thomann.de](http://www.thomann.de)

17.06.2021, ID: 230513, 354548 (V2)

---

# Table of contents

<b>1</b>	<b>General information</b> .....	<b>4</b>
	1.1 Further information.....	5
	1.2 Notational conventions.....	6
	1.3 Symbols and signal words.....	6
<b>2</b>	<b>Safety instructions</b> .....	<b>9</b>
<b>3</b>	<b>Features</b> .....	<b>13</b>
<b>4</b>	<b>Installation</b> .....	<b>14</b>
	4.1 Pin assignment.....	15
	4.2 Tips on handling speakers.....	18
	4.3 Hanging the speaker box.....	19
<b>5</b>	<b>Operating elements</b> .....	<b>20</b>
<b>6</b>	<b>Technical specifications</b> .....	<b>23</b>
<b>7</b>	<b>Protecting the environment</b> .....	<b>26</b>

# 1 General information

This user manual contains important information on the safe operation of the device. Read and follow all safety notes and all instructions. Save this manual for future reference. Make sure that it is available to all persons using this device. If you sell the device to another user, be sure that they also receive this manual.

Our products and user manuals are subject to a process of continuous development. We therefore reserve the right to make changes without notice. Please refer to the latest version of the user manual which is ready for download under [www.thomann.de](http://www.thomann.de).

## 1.1 Further information

On our website ([www.thomann.de](http://www.thomann.de)) you will find lots of further information and details on the following points:

Download	This manual is also available as PDF file for you to download.
Keyword search	Use the search function in the electronic version to find the topics of interest for you quickly.
Online guides	Our online guides provide detailed information on technical basics and terms.
Personal consultation	For personal consultation please contact our technical hotline.
Service	If you have any problems with the device the customer service will gladly assist you.

## 1.2 Notational conventions

This manual uses the following notational conventions:

### Letterings



The letterings for connectors and controls are marked by square brackets and italics.

**Examples:** *[VOLUME]* control, *[Mono]* button.

## 1.3 Symbols and signal words

In this section you will find an overview of the meaning of symbols and signal words that are used in this manual.

Signal word	Meaning
<b>DANGER!</b>	This combination of symbol and signal word indicates an immediate dangerous situation that will result in death or serious injury if it is not avoided.
<b>WARNING!</b>	This combination of symbol and signal word indicates a possible dangerous situation that can result in death or serious injury if it is not avoided.
<b>CAUTION!</b>	This combination of symbol and signal word indicates a possible dangerous situation that can result in minor injury if it is not avoided.
<b>NOTICE!</b>	This combination of symbol and signal word indicates a possible dangerous situation that can result in material and environmental damage if it is not avoided.
Warning signs	Type of danger
	Warning – high-voltage.

Warning signs	Type of danger
 A yellow triangular warning sign with a black border, depicting a crane hook lifting a load.	Warning – suspended load.
 A yellow triangular warning sign with a black border, featuring a large black exclamation mark.	Warning – danger zone.



## 2 Safety instructions

### Intended use

This device is designed for sound reinforcement. Use the device only as described in this user manual. Any other use or use under other operating conditions is considered to be improper and may result in personal injury or property damage. No liability will be assumed for damages resulting from improper use.

This device may be used only by persons with sufficient physical, sensorial, and intellectual abilities and having corresponding knowledge and experience. Other persons may use this device only if they are supervised or instructed by a person who is responsible for their safety.

### Safety



#### **DANGER!**

#### **Danger for children**

Ensure that plastic bags, packaging, etc. are disposed of properly and are not within reach of babies and young children. Choking hazard! Ensure that children do not detach any small parts (e.g. knobs or the like) from the unit. They could swallow the pieces and choke! Never let children unattended use electrical devices.

**DANGER!****Electric shock caused by short-circuit**

Always use proper ready-made insulated mains cabling (power cord) with a protective contact plug. Do not modify the mains cable or the plug. Failure to do so could result in electric shock/death or fire. If in doubt, seek advice from a registered electrician.

**DANGER!****Electric shock caused by high voltages inside**

Within the device there are areas where high voltages may be present. Never remove any covers. There are no user-serviceable parts inside. Do not use the device if covers, protectors or optical components are missing or damaged.

**WARNING!****Consequences of faulty mounting**

Faulty mounting may lead to lethal injuries or property damage. Please ensure that the norms and regulations valid in your country are always observed when mounting and operating your product. In Germany: BGV C1, "Event and Production Sites for Stage Presentations". Only expertly trained staff may mount speakers.

**CAUTION!****Possible hearing damage**

The device can produce volume levels that may cause temporary or permanent hearing impairment. Over an extended period of time, even levels that seem to be uncritical can cause hearing damage. Decrease the volume level immediately if you experience ringing in your ears or hearing impairment. If this is not possible, keep a greater distance or use sufficient ear protectors.



**NOTICE!**

**Risk of fire**



Do not block areas of ventilation. Do not install the device near any direct heat source. Keep the device away from naked flames.



**NOTICE!**

**Operating conditions**



This device has been designed for indoor use only. To prevent damage, never expose the device to any liquid or moisture. Avoid direct sunlight, heavy dirt, and strong vibrations. Only operate the device within the ambient conditions specified in the chapter 'Technical specifications' of this user manual. Avoid heavy temperature fluctuations and do not switch the device on immediately after it was exposed to temperature fluctuations (for example after transport at low outside temperatures). Dust and dirt inside can damage the unit. When operated in harmful ambient conditions (dust, smoke, nicotine, fog, etc.), the unit should be maintained by qualified service personnel at regular intervals to prevent overheating and other malfunction.



**NOTICE!**

**Power supply**



Before connecting the device, ensure that the input voltage (AC outlet) matches the voltage rating of the device and that the AC outlet is protected by a residual current circuit breaker. Failure to do so could result in damage to the device and possibly injure the user. Unplug the device before electrical storms occur and when it is unused for long periods of time to reduce the risk of electric shock or fire.



**NOTICE!**

**Possible damage due to installation of a wrong fuse**



The use of different types of fuses can cause serious damage to the unit. Fire hazard! Only fuses of the same type may be used.



### **NOTICE!**

#### **Possible staining**

The plasticiser contained in the rubber feet of this product may possibly react with the coating of your parquet, linoleum, laminate or PVC floor and after some time cause permanent dark stains. In case of doubt, do not put the rubber feet directly on the floor, but use felt-pad floor protectors or a carpet.

### 3 Features

Special features of the device:

- Active 2 way-full-range-loudspeaker with built-in crossover
- Connection options: XLR / 1/4" jack combo socket for signal input, XLR panel plug for signal output.
- Power supply switch
- Flying tracks on top of the housing and an eye on the back for tilting. Mounting for vertical hanging optionally available
- 36 mm pole flange on the bottom
- Rotatable horn
- Black textured paint (item no. 230513) or white textured paint (item no. 354548)

## 4 Installation

Unpack and check carefully there is no transportation damage before using the unit. Keep the equipment packaging. To fully protect the product against vibration, dust and moisture during transportation or storage use the original packaging or your own packaging material suitable for transport or storage, respectively.

Create all connections while the device is off. Use the shortest possible high-quality cables for all connections. Take care when running the cables to prevent tripping hazards.



### **WARNING!**

#### **Risk of injury caused by falling objects**

Make sure that the installation complies with the standards and rules that apply in your country. Always secure the device with a secondary safety attachment, such as a safety cable or a safety chain.

**NOTICE!****Possible property damage by magnetic fields**

Loudspeakers produce a static magnetic field. Therefore, maintain an appropriate distance to devices that can be adversely affected or damaged by an external magnetic field.

**NOTICE!****Use of stands**

When mounting the device onto a stand, ensure that the stand is in a safe and stable position and that the weight of the device does not exceed the maximum permissible load capacity of the stand.

## 4.1 Pin assignment

You may use XLR and jack connectors with either balanced or unbalanced pinout. Below you will find an overview of the different options.

## XLR connections for signal inputs/outputs

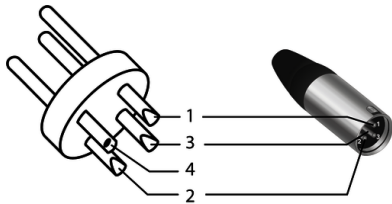

XLR panel sockets are provided for signal inputs. XLR panel plugs are provided for signal outputs. The figure and the table show the XLR pin assignment.

Balanced pinout:

1	Ground
2	Positive signal (+)
3	Negative signal (-)

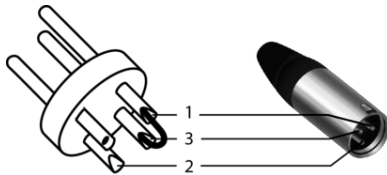

Unbalanced pinout:

1	Ground
2	Signal
3	Jumpered with pin 1



**Jack plug for signal in and outputs**

The figure and the table show the pin assignment for ¼-inch jack plugs.

Unbalanced wiring (jack plug, mono):

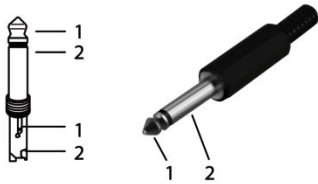

1	Signal
2	Ground

Unbalanced wiring (jack plug, stereo):

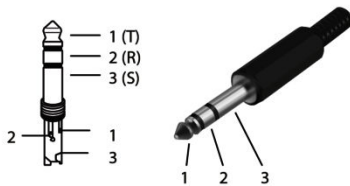

1	Signal
2, 3	Ground

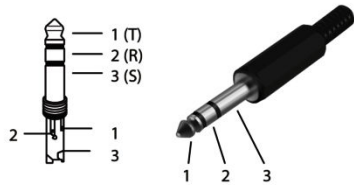

Balanced wiring (jack plug, stereo):

1 (tip)	Positive signal (+)
2 (ring)	Negative signal (-)
3 (sleeve)	Ground

## 4.2 Tips on handling speakers

We recommend you to set up the speakers in a way, that the sound signals can reach the audience unobstructedly. It will often be helpful to mount the speakers on tripods. Thus, the sound will be evenly spread with maximum range throughout the audience area.

Always use high grade cable to connect your equipment. Otherwise you won't reach maximum sound quality.

If you notice distortion during operation, the active speaker is overloaded. This may permanently damage the device. Always reduce the volume as soon as you hear distortion.

### 4.3 Hanging the speaker box

To hang the speaker box on special mounting devices (aka 'flying'), the top of the box offers built-in Aeroquip or fly tracks. In these tracks safety eyelets (double studs) can be screwed or latched. Check the secure connection of the safety eyelets with the box carefully, before you use it in 'flying mode'.

Using an additional loop on the back of the box, it is possible to tilt the box. This additional loop must not solely be in charge to secure the entire suspended weight.

## 5 Operating elements

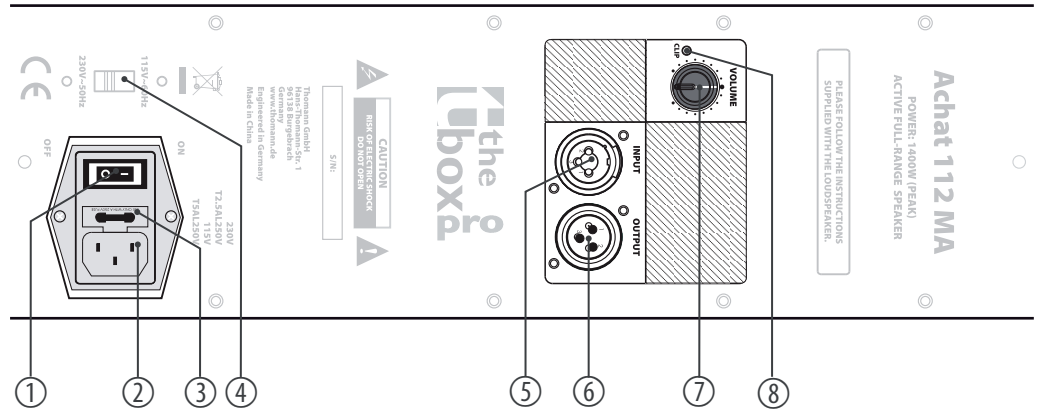

1	<i>[ON] / [OFF]</i> Use this switch (power switch) to turn the unit on and off.
2	IEC chassis plug for power supply with fuse holder
3	Fuse Should the fuse have blown, disconnect the unit from the power supply and replace the fuse with a new fuse of the same type.
4	<i>[115V/60Hz] / [230V/50Hz]</i> Power supply switch Make sure this selector is set correctly for the actual supply voltage at the operating location. Use this switch only when the device is switched off.
5	<i>[INPUT]</i> Line signal input, designed as XLR / 1/4" combo
6	<i>[OUTPUT]</i> Line signal output, designed as XLR panel plug

7	<i>[VOLUME]</i> Overall volume control
8	<i>[CLIP]</i> Indicates overload (clipping). In this case, the level of the line input signal is too high.

## 6 Technical specifications

Speaker		1 × 12" woofer, 1" mid-range neodymium transducer (with 3" voice coil)
Input connections	Line	1 × XLR / 1/4" jack combo socket (Line In)
	Power supply	IEC chassis plug C14
Input impedance		10 kΩ
Output connections		1 × XLR panel plug (Line Out)
Output power		RMS: 350 W
		Peak: 1400 W
Frequency range		60 Hz ... 18 kHz, -3 dB
Crossover frequency		2 kHz
Signal-to-noise ratio	Woofer	≥95 dB (630 Hz, typical)
	Tweeter	≥90 dB (6.3 kHz, typical)
Sound pressure level (SPL), max.		131 dB

Achat 112 MA Achat 112 MA WH

## Technical specifications

---

Distortion	Line: 0.02%	
Load impedance	8 $\Omega$	
Dispersion angle (V $\times$ H)	60° $\times$ 40° (horn)	
Supply voltage (selectable)	115 V $\sim$ 60 Hz or 230 V $\sim$ 50 Hz	
Fuse	115 V: 5 mm $\times$ 20 mm, 5 A, 250 V, slow-blow 230 V: 5 mm $\times$ 20 mm, 2.5 A, 250 V, slow-blow	
Dimensions (W $\times$ H $\times$ D)	360 mm $\times$ 360 mm $\times$ 610 mm	
Weight	24.7 kg	
Ambient conditions	Temperature range	0 °C...40 °C
	Relative humidity	20 %...80 % (non-condensing)



**Further information**

Monitor inclination	Yes
Bluetooth®	No
USB player	No
Fan	No
Housing	Wood
Colour	black (item no. 230513) or white (item no. 354548)
Protective cover	Suitable protective cover optionally available (item no. 243017)

## 7 Protecting the environment

### Disposal of the packaging material



For the transport and protective packaging, environmentally friendly materials have been chosen that can be supplied to normal recycling.

Ensure that plastic bags, packaging, etc. are properly disposed of.

Do not just dispose of these materials with your normal household waste, but make sure that they are collected for recycling. Please follow the notes and markings on the packaging.

### Disposal of your old device



This product is subject to the European Waste Electrical and Electronic Equipment Directive (WEEE) in its currently valid version. Do not dispose with your normal household waste.

Dispose of this device through an approved waste disposal firm or through your local waste facility. When discarding the device, comply with the rules and regulations that apply in your country. If in doubt, consult your local waste disposal facility.



Musikhaus Thomann · Hans-Thomann-Straße 1 · 96138 Burgebrach · Germany · [www.thomann.de](http://www.thomann.de)