

the
box **pro**

A 218 LA
active subwoofer

Musikhaus Thomann
Thomann GmbH
Hans-Thomann-Straße 1
96138 Burgebrach
Germany
Telephone: +49 (0) 9546 9223-0
E-mail: info@thomann.de
Internet: www.thomann.de

27.10.2015, ID: 313916

Table of contents

1	General notes.....	4
2	Safety instructions.....	7
3	Features.....	11
4	Installation.....	12
5	Connections and operating elements.....	14
6	Starting up	19
7	Networking and remote control	23
8	Technical specifications.....	27
9	Plug and connection assignment.....	29
10	Protecting the environment.....	31

1 General notes

This user manual contains important information on safe operation of the device. Read and follow all safety notes and all instructions. Save this manual for future reference. Make sure that it is available to all persons using this device. If you sell the device to other users, be sure that they also receive this manual.

Our products are subject to a process of continuous development. We therefore reserve the right to make changes without notice.

Symbols and signal words

This section provides an overview of the symbols and signal words used in this user manual.

Signal word	Meaning
DANGER!	This combination of symbol and signal word indicates an immediate dangerous situation that will result in death or serious injury if it is not avoided.
CAUTION!	This combination of symbol and signal word indicates a possible dangerous situation that can result in minor injury if it is not avoided.
NOTICE!	This combination of symbol and signal word indicates a possible dangerous situation that can result in material and environmental damage if it is not avoided.
Warning signs	Type of danger
	Warning – high-voltage.

Warning signs	Type of danger
	Warning – danger zone.

2 Safety instructions

Intended use

This device is intended to be used in a sound reinforcement system. Use the device only as described in this user manual. Any other use or use under other operating conditions is considered to be improper and may result in personal injury or property damage. No liability will be assumed for damages resulting from improper use.

This device may be used only by persons with sufficient physical, sensorial, and intellectual abilities and having corresponding knowledge and experience. Other persons may use this device only if they are supervised or instructed by a person who is responsible for their safety.

Safety



DANGER!

Danger for children

Ensure that plastic bags, packaging, etc. are disposed of properly and are not within reach of babies and young children. Choking hazard!

Ensure that children do not detach any small parts (e.g. knobs or the like) from the unit. They could swallow the pieces and choke!

Never let children unattended use electrical devices.



DANGER!

Electric shock caused by high voltages inside

Within the device there are areas where high voltages may be present. Never remove any covers.

There are no user-serviceable parts inside.



DANGER!

Electric shock caused by short-circuit

Always use proper ready-made insulated mains cabling (power cord). Do not modify the mains cable. Failure to do so could result in electric shock/death or fire. If in doubt, seek advice from a registered electrician.



CAUTION!

Possible hearing damage

The device can produce volume levels that may cause temporary or permanent hearing impairment. Over an extended period of time, even levels that seem to be uncritical can cause hearing damage.

Decrease the volume level immediately if you experience ringing in your ears or hearing impairment. If this is not possible, keep a greater distance or use sufficient ear protectors.



NOTICE!

Risk of fire

Do not cover the device nor any ventilation slots. Do not place the device near any direct heat source. Keep the device away from naked flames.



NOTICE!

Operating conditions

This device has been designed for indoor use only. To prevent damage, never expose the device to any liquid or moisture. Avoid direct sunlight, heavy dirt, and strong vibrations.



NOTICE!

Power supply

Before connecting the device, ensure that the input voltage (AC outlet) matches the voltage rating of the device and that the AC outlet is protected by a residual current circuit breaker. Failure to do so could result in damage to the device and possibly injure the user.

Unplug the device before electrical storms occur and when it is unused for long periods of time to reduce the risk of electric shock or fire.

3 Features

Special features of the device:

- Active subwoofer with 2 × 18" woofers (4" voice coils)
- 2 × 2000 W class D amplifier
- Internal Sound Processor (DSP) with four presets
- Connectivity options: XLR chassis socket for signal input, XLR chassis plug for signal output
- powerCON input
- Network port for connecting a notebook/PC using exclusively the CanBus converters (item no.: 326058 the box pro USB2CAN CanBus Converter) and the Pronet software (free download from www.thomann.de).
- Ten carrying handles
- Birch plywood housing with waterproof paint
- Four heavy-duty casters included

4 Installation

Unpack and carefully check that there is no transportation damage before using the unit. Keep the equipment packaging. To fully protect the device against vibration, dust and moisture during transportation or storage use the original packaging or your own packaging material suitable for transport or storage, respectively.

Establish all connections as long as the unit is switched off. Use the shortest possible high-quality cables for all connections.



CAUTION!

Risk of injury due to heavy weight

Due to the heavy weight of the device, at least two persons are required for transport and installation.



NOTICE!

Possible property damage by magnetic fields

Loudspeakers produce a static magnetic field. Therefore, maintain an appropriate distance to devices that can be adversely affected or damaged by an external magnetic field.

5 Connections and operating elements

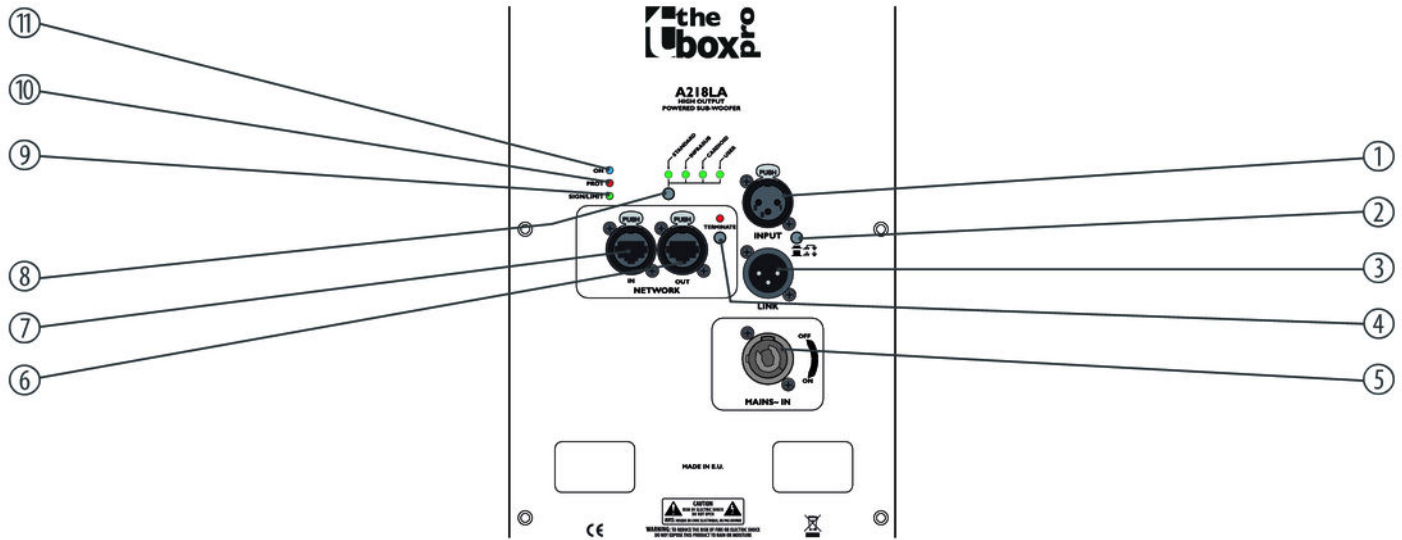

1	<p>INPUT</p> <p>Audio signal input with lockable XLR chassis socket. The socket is electronically perfectly symmetrical wired to achieve an optimal signal-to-noise ratio and a sufficient power reserve, including A / D conversion.</p>
2	<p><i>[GND LIFT]</i> pushbutton</p> <p>If hum is caused by a ground loop, you can use this switch to disconnect the connection between the earth pin of the device and the signal ground of the device. Switching only has an effect when using balanced connection cables.</p>
3	<p>LINK</p> <p>Audio signal output with XLR chassis plug to connect other line array elements or speakers to which the input signal is passed.</p>
4	<p><i>[TERMINATE]</i> pushbutton</p> <p>If the devices is networked together with Line Array elements, the last unit must be terminated with the built-in load resistance. Press the pushbutton <i>[TERMINATE]</i>. The LED above it lights up.</p>
5	<p>MAINS IN</p> <p>Blue lockable powerCON input socket (NAC3FA). To turn the unit on, plug the powerCON power cord or the powerCON connector cable from another device into this socket and turn the plug clockwise to the position ON. To turn the unit off, pull the locking lever on the plug backwards and turn the plug counter-clockwise to the position PUSH OFF.</p>

6, 7 **NETWORK IN/OUT**

RJ45 CAT5 connectors for establishing a network connection to the CanBus Converter (item number 326058), to the Pronet software and to the line array elements.

8 Preset button

This button has two functions:

- If it's kept pressed while turning the device on, the ID assignment is made. The internal digital signal processor (DSP) assigns a new ID to the device for the remote control within the Pronet network. Each element must have a unique ID so that it can be represented in the Pronet network. If you assign a new ID, all elements with already assigned IDs must be turned on and connected to the Pronet network.
- If the elements is already on, pressing the button selects the DSP preset. The selected preset is indicated by the corresponding LED.
 - **STANDARD**
This setting is suitable for all applications where the frequency range up to 90 Hz is to be transmitted and amplified. The setting is suitable for most environments and for combinations with vertically flown Line Arrays.
 - **INFRA**
This setting can be used when a deeper 'response' in the bass range is required. This will slightly reduce the sound pressure of the system. Note that the settings **STANDARD** and **INFRA** must not be used by two adjacent devices at a time.
 - **CARDIOID**
This setting is useful for a device that is aligned to the stage in the back of two other subwoofers. The bass level is reduced towards the stage. For a sample application, see ↗ *'Application example for stacked subwoofers' on page 20.*
 - **USER**

	<p>This LED lights up when the user setting is loaded. This setting corresponds to the user preset no. 1 of the DSP. In delivered condition, the user setting is identical to the setting STANDARD. If you want to change it, you must connect the element to a PC, edit the parameters using the Pronet software, and save the setting to user memory preset no. 1.</p>
9	<p>LED SIGN/LIMIT</p> <p>This LED lights green when an input signal is present.</p> <p>This LED lights red when the internal output signal is limited (due to excessive input signal level!).</p>
10	<p>LED PROT</p> <p>This LED lights red when the protection circuit of the amplifier module responds due to an internal error and the amplifier is therefore muted.</p> <p>This LED lights red when the internal output signal is limited (due to excessive input signal level!).</p>
11	<p>LED ON</p> <p>This LED lights green when the unit is turned on and the power supply voltage is present.</p>

6 Starting up

Switching on

After you have made all the required connections, turn on the audio system.

It is recommended to provide one switch for turning on the entire audio system and to always leave the powerCon plugs connected to the sockets of the individual elements. With this simple trick you can extend the life of the powerCON connectors.

DSP preset

Set the desired DSP preset (**STANDARD**, **INFRA**, **CARDIOID** or **USER**).

Application example for stacked subwoofers

The units can be combined vertically or horizontally to subwoofer stacks. Of each three devices, the middle one should aim to the stage working with the DSP preset **CARDIOID**. The other two devices point toward the audience and work with the DSP preset **STANDARD**. By this configuration, the bass level for the artists on stage is reduced, but maximized for the audience.

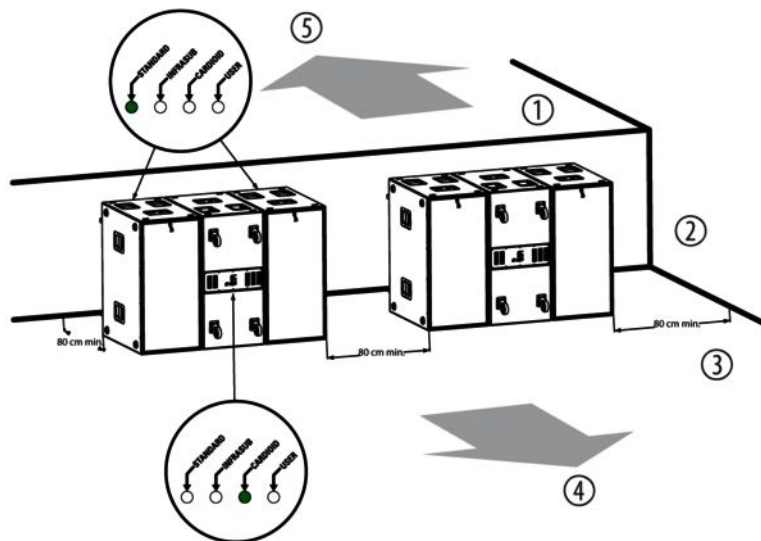

A 218 LA

1	Stage.
2	Wall or huge obstacle.
3	Auditorium.
4	Doubled bass.
5	Reduced bass.

Subwoofer stacks must be placed at a distance of 80 cm from walls and fixed obstacles, so that the sound is not affected by reflections.

7 Networking and remote control

Network capability

Using the network ports on the rear panel, the individual devices of the entire audio system can be networked and controlled remotely with a notebook or PC.

Pronet

The communication protocol used in the Pronet network is CanBus.

USB2CAN

All you need to build such a network is the free Thomann Pronet software offered in the Thomann Cyberstore for download, the CanBus Converter (item number 326058) available from Thomann and a notebook or PC. Installation and user's guides are included in the free download of the software.

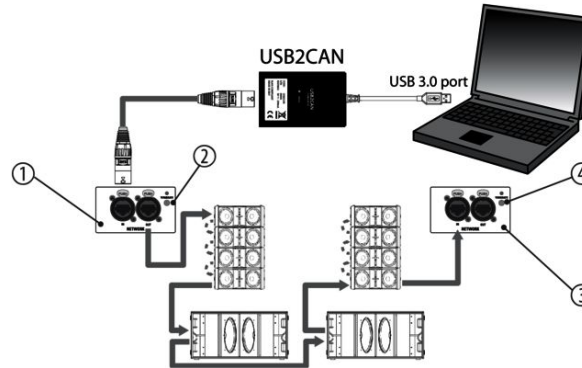

- 1 Network ports on the rear panel of the first unit.
- 2 [TERMINATE] pushbutton must not be pressed.
The LED above it is off.

3	Network ports on the rear panel of the last unit.
4	[<i>TERMINATE</i>] pushbutton must be pressed. The LED above it is on.

Network setup and termination

The individual units must be linearly linked by RJ45 CAT5 cable. Beginning and end of the network bus must be terminated. The beginning is terminated by the CanBus converter. At the end, the [*TERMINATE*] switch must be pressed on the rear panel of the last unit to enable the built-in terminating resistor for termination. The [*TERMINATE*] switch on all units between the CanBus converter and the last device must not be pressed.

ID assignment

Each device of a Pronet network must have a unique identifier or ID. By default, the USB2CAN converter has the ID 0. Any other device can only have an ID equal or higher than 1. There must be no devices with the same ID on the network. The ID is assigned automatically when a device connected to the network is turned on for the first time.

Proceed as follows to assign a unique ID to all devices in the Pronet network:

1. ➤ Turn off all devices.
2. ➤ Connect them with the RJ-45 CAT5 cables in the desired order.

3. ▶ Press the *[TERMINATE]* button on the rear panel of the last unit.
4. ▶ Turn on the first device while keeping its *[PRESET]* button pressed on the rear panel.
5. ▶ Leave the first device turned on and repeat step 4 for all other devices until the last device is turned on.

When a new device is to be added, only step 4 must be repeated. Each device keeps its ID, even if it is turned off, as it is stored in the internal memory of the device. The ID is only deleted or reassigned by explicit allocation as described above. Find more detailed information and instructions in the User Manual supplied with the Pronet software.

8 Technical specifications

Speakers	2 × 18" woofers (4" voice coil)
Input	XLR chassis socket (balanced)
Input impedance	20 kΩ
Input sensitivity	+4 dBu / 1.25 V
Output	XLR chassis plug
Frequency response	36 Hz ... 100 Hz (–3 dB)
Output power	2 × 2000 W (RMS)
Sound pressure level (in 1 m distance)	141 dB (max.)
Operating supply voltage	230 V ~, 50 Hz
Power consumption	1400 W (nominal)
	3400 W (maximum)

Technical specifications

Dimensions (W × H × D, without casters)	1215 mm × 590 mm × 950 mm
Weight	101.7 kg

9 Plug and connection assignment

Introduction

This chapter will help you select the right cables and plugs to connect your valuable equipment in such a way that a perfect sound experience is ensured.

Please note these advices, because especially in 'Sound & Light' caution is indicated: Even if a plug fits into the socket, an incorrect connection may result in a destroyed power amp, a short circuit or 'just' in poor transmission quality!

Balanced and unbalanced transmission

Unbalanced transmission is mainly used in semi-professional environment and in hifi use. Instrument cables with two conductors (one core plus shielding) are typical representatives of the unbalanced transmission. One conductor is ground and shielding while the signal is transmitted through the core.

Unbalanced transmission is susceptible to electromagnetic interference, especially at low levels, such as microphone signals and when using long cables.

In a professional environment, therefore, the balanced transmission is preferred, because this enables an undisturbed transmission of signals over long distances. In addition to the conductors 'Ground' and 'Signal', in a balanced transmission a second core is added. This also transfers the signal, but phase-shifted by 180°.

Since the interference affects both cores equally, by subtracting the phase-shifted signals, the interfering signal is completely neutralized. The result is a pure signal without any noise interference.

XLR plug (balanced)

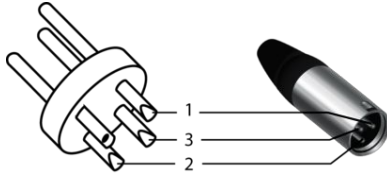

1	Ground, shielding
2	Signal (in phase, +)
3	Signal (out of phase, -)

10 Protecting the environment

Disposal of the packaging material



For the transport and protective packaging, environmentally friendly materials have been chosen that can be supplied to normal recycling.

Ensure that plastic bags, packaging, etc. are properly disposed of.

Do not just dispose of these materials with your normal household waste, but make sure that they are collected for recycling. Please follow the notes and markings on the packaging.

Disposal of your old device



This product is subject to the European Waste Electrical and Electronic Equipment Directive (WEEE). Do not dispose with your normal household waste.

Dispose of this device through an approved waste disposal firm or through your local waste facility. When discarding the device, comply with the rules and regulations that apply in your country. If in doubt, consult your local waste disposal facility.

A 218 LA



Musikhaus Thomann · Hans-Thomann-Straße 1 · 96138 Burgebrach · Germany · www.thomann.de