



Tri Flat PAR Profile 18x3W RGB 25°, 45°

LED PAR

Thomann GmbH

Hans-Thomann-Straße 1

96138 Burgebrach

Germany

Telephone: +49 (0) 9546 9223-0

Internet: www.thomann.de

13.07.2022, ID: 317335, 414494 (V6)

Table of contents

1	General information	6
	1.1 Further information.....	7
	1.2 Notational conventions.....	7
	1.3 Symbols and signal words.....	8
2	Safety instructions	10
3	Features	14
4	Installation	15
5	Starting up	19
6	Connections and operating elements	21
7	Operating	27
	7.1 Starting the device.....	27
	7.2 Main menu.....	27
	7.3 Menu overview.....	31
	7.4 Temperature monitoring.....	32
	7.5 Functions in 3-channel DMX mode.....	32
	7.6 Functions in 5-channel DMX mode.....	33
	7.7 Functions in 7-channel DMX mode.....	33
	7.8 Remote control.....	36
8	Technical specifications	39

9	Plug and connection assignments	41
10	Troubleshooting	42
11	Cleaning	44
12	Protecting the environment	45



Tri Flat PAR Profile 18x3W RGB 25°, 45°
LED PAR

1 General information

This user manual contains important information on the safe operation of the device. Read and follow all safety notes and all instructions. Save this manual for future reference. Make sure that it is available to all persons using this device. If you sell the device to another user, be sure that they also receive this manual.

Our products and user manuals are subject to a process of continuous development. We therefore reserve the right to make changes without notice. Please refer to the latest version of the user manual which is ready for download under www.thomann.de.

1.1 Further information

On our website (www.thomann.de) you will find lots of further information and details on the following points:

Download	This manual is also available as PDF file for you to download.
Keyword search	Use the search function in the electronic version to find the topics of interest for you quickly.
Online guides	Our online guides provide detailed information on technical basics and terms.
Personal consultation	For personal consultation please contact our technical hotline.
Service	If you have any problems with the device the customer service will gladly assist you.

1.2 Notational conventions

This manual uses the following notational conventions:

Letterings

The letterings for connectors and controls are marked by square brackets and italics.

Examples: *[VOLUME]* control, *[Mono]* button.

Displays





Texts and values displayed on the device are marked by quotation marks and italics.

Examples: '24ch', 'OFF'.

1.3 Symbols and signal words

In this section you will find an overview of the meaning of symbols and signal words that are used in this manual.

Signal word	Meaning
DANGER!	This combination of symbol and signal word indicates an immediate dangerous situation that will result in death or serious injury if it is not avoided.
WARNING!	This combination of symbol and signal word indicates a possible dangerous situation that can result in death or serious injury if it is not avoided.
NOTICE!	This combination of symbol and signal word indicates a possible dangerous situation that can result in material and environmental damage if it is not avoided.

Warning signs	Type of danger
	Warning – high-voltage.
	Warning – dangerous optical radiation.
	Warning – suspended load.
	Warning – danger zone.

2 Safety instructions

Intended use

This device is intended for use as an electronic lighting effect by means of LED technology. The device is designed for professional use only and is not suitable for use in households. Use the device only as described in this user manual. Any other use or use under other operating conditions is considered to be improper and may result in personal injury or property damage. No liability will be assumed for damages resulting from improper use.

This device may be used only by persons with sufficient physical, sensorial, and intellectual abilities and having corresponding knowledge and experience. Other persons may use this device only if they are supervised or instructed by a person who is responsible for their safety.



Extend the operating life of the device by regular breaks and by avoiding frequent switching on and off. The device is not suitable for continuous operation.

Safety



DANGER!

Danger for children

Ensure that plastic bags, packaging, etc. are disposed of properly and are not within reach of babies and young children. Choking hazard! Ensure that children do not detach any small parts (e.g. knobs or the like) from the unit. They could swallow the pieces and choke! Never let children unattended use electrical devices.



DANGER!

Electric shock caused by high voltages inside

Within the device there are areas where high voltages may be present. Never remove any covers. There are no user-serviceable parts inside. Do not use the device if covers, protectors or optical components are missing or damaged.



DANGER!

Electric shock caused by short-circuit

Always use proper ready-made insulated mains cabling (power cord) with a protective contact plug. Do not modify the mains cable or the plug. Failure to do so could result in electric shock/death or fire. If in doubt, seek advice from a registered electrician.



WARNING!

Eye damage caused by high light intensity

Never look directly into the light source.



WARNING!

Risk of epileptic shock

Strobe lighting can trigger seizures in photosensitive epilepsy. Sensitive persons should avoid looking at strobe lights.



NOTICE!

Risk of fire

Do not block areas of ventilation. Do not install the device near any direct heat source. Keep the device away from naked flames.



NOTICE!

Operating conditions

This device has been designed for indoor use only. To prevent damage, never expose the device to any liquid or moisture. Avoid direct sunlight, heavy dirt, and strong vibrations. Only operate the device within the ambient conditions specified in the chapter 'Technical specifications' of this user manual. Avoid heavy temperature fluctuations and do not switch the device on immediately after it was exposed to temperature fluctuations (for example after transport at low outside temperatures). Dust and dirt inside can damage the unit. When operated in harmful ambient conditions (dust, smoke, nicotine, fog, etc.), the unit should be maintained by qualified service personnel at regular intervals to prevent overheating and other malfunction.



NOTICE!

Power supply

Before connecting the device, ensure that the input voltage (AC outlet) matches the voltage rating of the device and that the AC outlet is protected by a residual current circuit breaker. Failure to do so could result in damage to the device and possibly injure the user. Unplug the device before electrical storms occur and when it is unused for long periods of time to reduce the risk of electric shock or fire.



NOTICE!

Possible damage due to installation of a wrong fuse

The use of different types of fuses can cause serious damage to the unit. Fire hazard! Only fuses of the same type may be used.



NOTICE!

Fire hazard due to exceedance of the maximum current

The device can power other devices of identical construction. The current consumption of all other devices connected in series must not exceed the values indicated in the technical specifications. Otherwise you risk injuries and irreparable damages to the device. Only connect so many identical devices that the maximum current consumption is not exceeded. Ensure the sufficient dimensioning (wire cross section) of the power cables used for all devices connected in series.



NOTICE!

Risk of fire due to incorrect polarity

- Incorrectly inserted batteries may destroy the device or the batteries. Ensure that proper polarity is observed when inserting batteries.



NOTICE!

Possible damage by leaking batteries

- Leaking batteries can cause permanent damage to the device. Take batteries out of the device if it is not going to be used for a longer period.



NOTICE!

Possible staining

- The plasticiser contained in the rubber feet of this product may possibly react with the coating of your surface and after some time cause permanent dark stains. In case of doubt, do not put the rubber feet directly on the surface and use a suitable underlay if necessary, i.e. felt pads or similar.

3 Features

The LED PAR is particularly suitable for lighting applications in clubs and discotheques, on rock stages, in theatres and musicals.

Special features of the device:

- 18 tri-colour LEDs (3 W each)
- Control via DMX (three different modes), via buttons and display on the device and supplied IR remote control (item no. 322277)
- Nine preprogrammed automatic shows
- Sound control
- Master / slave mode
- Robust metal housing with compact design

For technological reasons, the light output of LEDs decreases over their lifetime. This effect increases with higher operating temperature. You can extend the service life of the illuminants by providing adequate ventilation and operating the LEDs with the lowest possible brightness.

4 Installation

Unpack and check carefully there is no transportation damage before using the unit. Keep the equipment packaging. To fully protect the product against vibration, dust and moisture during transportation or storage use the original packaging or your own packaging material suitable for transport or storage, respectively.



WARNING!

Risk of injury caused by falling objects

Make sure that the installation complies with the standards and rules that apply in your country. Always secure the device with a secondary safety attachment, such as a safety cable or a safety chain.



NOTICE!

Risk of overheating

The distance between light output and the illuminated surface must be more than 1.5 m (19.7in).

Provide sufficient ventilation.

The ambient temperature must always be below 40 °C (104 °F).



NOTICE!

Use of stands

When mounting the device onto a stand, ensure that the stand is in a safe and stable position and that the weight of the device does not exceed the maximum permissible load capacity of the stand.



NOTICE!

Possible data transmission errors

For error-free operation make use of dedicated DMX cables and do not use ordinary microphone cables.

Never connect the DMX input or output to audio devices such as mixers or amplifiers.



Please note that this device must not be connected to a dimmer.

Mounting options

You can install the unit in hanging or standing position. When in use, the device must always be attached to a solid surface or an approved truss. Use the openings provided on the two-piece bracket for attaching.

Always work from a stable platform whenever installing, moving or servicing the unit. In doing so, the area underneath the unit must be cordoned off.

The safety cable must be attached to the bracket.

Infrared sensor for the remote control

The infrared sensor for the signals of the remote control is located near the main LED on the front panel of the device. Make sure it's not obstructed.

Inserting the battery into the remote control

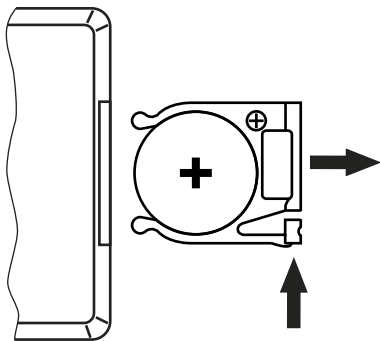

Press the lock of the battery holder to the centre of the housing and pull out the battery holder like a drawer. Insert the battery. The battery is correct if the positive pole points to the housing base of the remote control. Slide the battery holder back into the remote until it clicks into place.

When shipping, the battery is already installed in the remote and protected against discharge by a transparent plastic foil. Remove the plastic foil prior to first use.



NOTICE!

Risk of fire due to incorrect polarity

Incorrectly inserted batteries may destroy the device or the batteries.

Ensure that proper polarity is observed when inserting batteries.



NOTICE!

Possible damage by leaking batteries

Leaking batteries can cause permanent damage to the device.

Take batteries out of the device if it is not going to be used for a longer period.

5 Starting up

Create all connections while the device is off. Use the shortest possible high-quality cables for all connections. Take care when running the cables to prevent tripping hazards.

Connections in DMX mode

Connect the DMX input of the device to the DMX output of a DMX controller or another DMX device. Connect the output of the first DMX device to the input of the second one, and so on to form a daisy chain. Always ensure that the output of the last DMX device in the daisy chain is terminated with a resistor ($110\ \Omega$, $\frac{1}{4}\ \text{W}$).

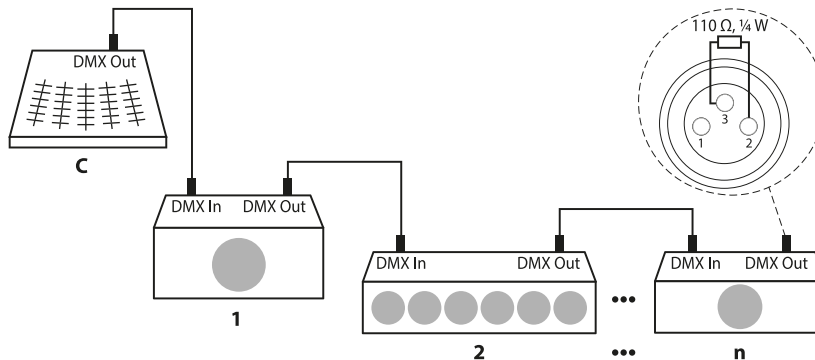

DMX indicator

If the unit is in DMX mode and a DMX controller is connected and turned on, the 'd' is flashing in the first digit of the display.

Connections in master/slave mode

When you configure a group of devices in master/slave mode, the first unit will control the other units for an automatic, sound-activated, synchronized show. This function is ideal when you want to start a show immediately. Connect the DMX output of the master device to the DMX input of the first slave device. Then connect the DMX output of the first slave device to the DMX input of the second slave device and so on.

6 Connections and operating elements

Overview

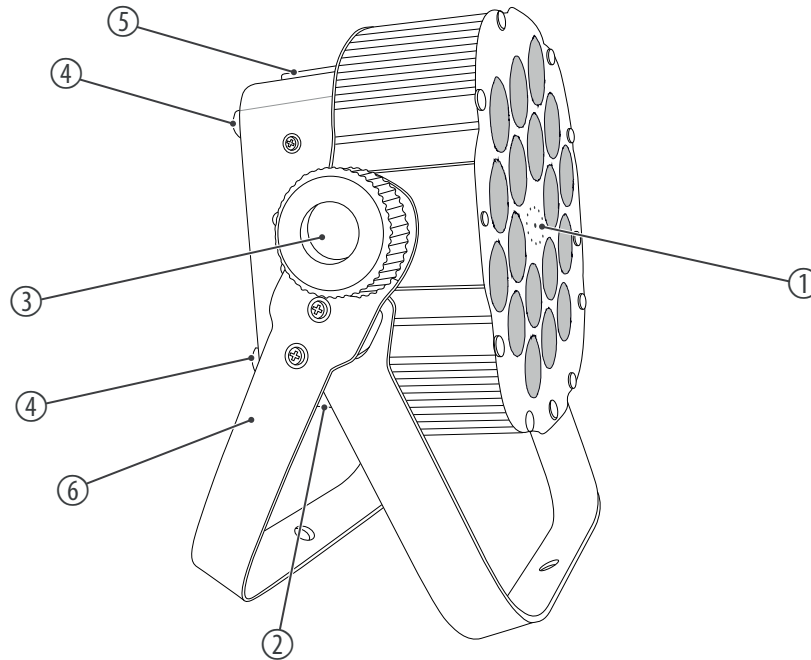

Connections and operating elements

1	Infrared sensor for the remote control signals
2	Bottom side with inputs (DMX and power supply)
3	Locking screws for the mounting brackets
4	Rubber feet for floor placement
5	Tops side with operating elements
6	Mounting brackets for floor placement or hanging

Connection panel

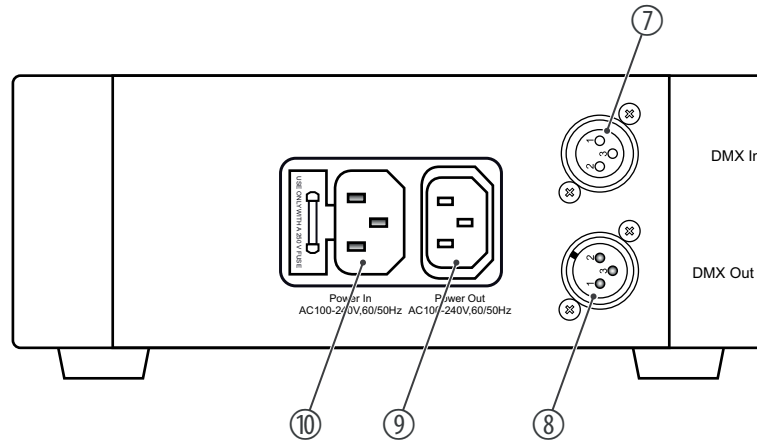

7	[DMX In] DMX input
8	[DMX Out] DMX output
9	[Power Out] IEC chassis socket for the power supply cable to the next unit
10	[Power In] IEC chassis plug for power supply with fuse holder

Operating elements

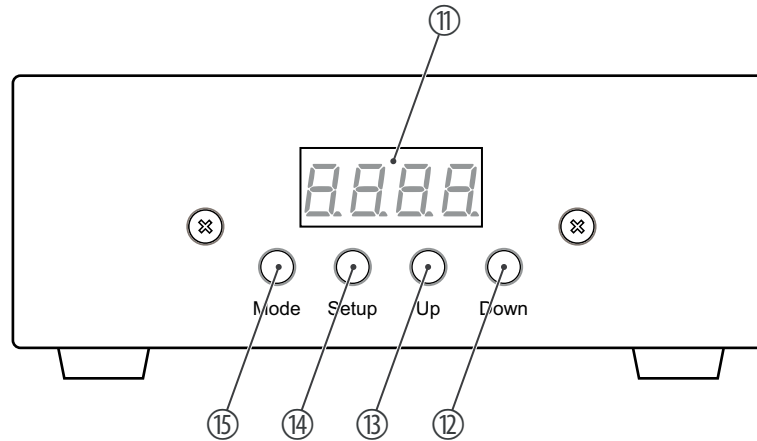

- | | |
|----|---|
| 11 | Display |
| 12 | <i>[Down]</i> navigates downwards in a menu list. Decreases the displayed value by one. |
| 13 | <i>[Up]</i> navigates upwards in a menu list. Increases the displayed value by one. |
| 14 | <i>[Setup]</i> selects an option of the respective operating mode. |
| 15 | <i>[Mode]</i> activates the main menu and toggles between menu items. |

Infrared remote control (item no. 322277)



Since the universal remote control can be used for several device types, some buttons may not be assigned and therefore have no function.

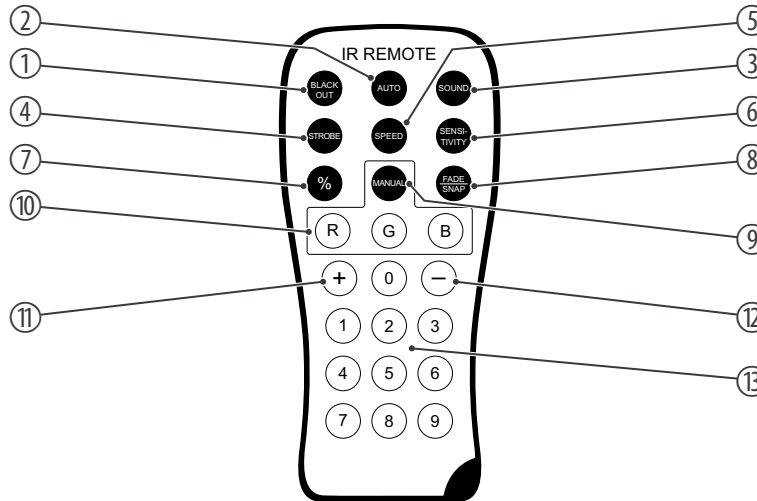

1	<i>[BLACK OUT]</i> enables or disables blackout.
2	<i>[AUTO]</i> activates the 'Automatic' mode.
3	<i>[SOUND]</i> activates the 'Sound-control' mode.
4	<i>[STROBE]</i> enables or disables the strobe effect with the last selected colour.
5	<i>[SPEED]</i> enables the setting mode for the strobe speed. Adjust the speed using <i>[+]</i> and <i>[-]</i> .
6	<i>[SENSITIVITY]</i> enables the setting mode for the sound control. Set the sensitivity of the built-in microphone with <i>[+]</i> and <i>[-]</i> .
7	<i>[%]</i> resets the displayed value to zero when adjusting values (strobe speed, sensitivity of the sound control).
8	<i>[FADE / SNAP]</i> no function
9	<i>[MANUAL]</i> activates the display of a constant colour, that can either be mixed individually with <i>[R]</i> , <i>[G]</i> and <i>[B]</i> from the basic colours, or selected directly with one of the coloured buttons.
10	<i>[R], [G], [B]</i> sets the intensity of the three primary colours red, green and blue when a constant colour is displayed.
11	<i>[+]</i> increases the set value.
12	<i>[-]</i> decreases the set value.
13	<i>[0 ... 9]</i> numeric buttons for direct selection of a mixed colour.

7 Operating

7.1 Starting the device

Connect the device to the power supply to start operation. After a few seconds, the display indicates that a reset is in progress. The device is then ready for use. The display shows the operating mode that was selected when the unit was last powered off.

7.2 Main menu

Press *[Mode]* to activate the main menu and select an operating mode. Use *[Setup]* to select further options. Use *[Up]* and *[Down]* to change the respectively displayed value. The unit instantly applies the displayed value, you don't need to push a button for confirmation.

If you don't press any button for about ten seconds the display turns off. It will be reactivated to display the previously shown menu by pressing any button.

The set values are retained even when the device is disconnected from the mains power supply. To delete all settings made by you, follow the notes in chapter ↪ *'Reset to factory defaults'* on page 31.

Operating mode 'Preprogrammed automatic show'

A preprogrammed automatic show can only be activated when the unit is operating in stand-alone mode or as master in a master / slave combination. This setting is only relevant if the device is not controlled via DMX.

Press *[Mode]* repeatedly until the display shows 'Pr.xx'. Now you can select one of the preprogrammed automatic shows. Use *[Up]* and *[Down]* to select a value between 'Pr.01' and 'Pr.09'.

Settings for programme 01:

For 'Pr.01', you can choose from 10 predefined colours or blackout. Press *[Setup]*. Using *[Up]* and *[Down]*, you can now select one of the colours (display '1.__r' to '09.on') or blackout (display '0.OFF').

To adjust the strobe frequency, press *[Setup]* again. The display shows 'FS.xx'. Now use *[Up]* and *[Down]* to select a value between 'FS.00' (slow) and 'FS.99' (fast).

Settings for programmes 02 to 09:

To adjust the programme speed, press again *[Setup]*. The display shows 'SP.xx'. Now use *[Up]* and *[Down]* to select a value between 'SP.01' (slow) and 'SP.FL' (fast).

To adjust the strobe frequency, press *[Setup]* again. The display shows 'FS.xx'. Now use *[Up]* and *[Down]* to select a value between 'FS.00' (slow) and 'FS.99' (fast).

Operating mode 'Automatic'

Automatic operation can only be activated when the unit is operating in stand alone mode or as master in a master / slave combination. This setting is only relevant if the device is not controlled via DMX.

Press *[Mode]* repeatedly until the display shows 'AUTO'. The playback of the built-in automatic program starts automatically.

DMX mode

This setting is only relevant when the device is controlled via DMX.

Press *[Mode]* until the display shows 'd.xxx'.

Now you can set the number of the first DMX channel to be used by the device (DMX address). Use *[Up]* and *[Down]* to select a value between 1 and 512 (display shows 'd.001' ... 'd.512').

Make sure that this number matches the configuration of your DMX controller. The following table shows the highest possible DMX address for the various DMX modes.

Mode	Highest possible DMX address
3-channel	510
5-channel	508
7-channel	506

Press *[Setup]*. With *[Up]* and *[Down]* you can select one of the following DMX operating modes:

- '3-ch' (three channels)
- '5-ch' (five channels)
- '7-ch' (seven channels)

Operating mode 'Slave'

This setting is only relevant if the device is serving as Slave in a Master / Slave configuration and is not controlled via DMX.

Press *[Mode]* repeatedly until the display shows 'SLAv'.

Sound control

The sound controlled automatic show can only be activated when the unit is operating in stand alone mode or as master in a master / slave combination. This setting is only relevant if the device is not controlled via DMX.

Press *[Mode]* repeatedly until the display shows 'SOud'. This activates the sound controlled automatic show.

Press *[Setup]* and use *[Up]* and *[Down]* to adjust the sensitivity for the sound control in a range from 'SV.00' to 'SV.31'.

Constant colour

A constant colour can only be activated when the unit is operating in stand-alone mode or as master in a master / slave combination. This setting is only relevant if the device is not controlled via DMX.

Press *[Mode]* until the display shows 'Colr'. Press *[Setup]*. The display shows the setting for one of the primary colours (display shows 'r.xxx', 'G.xxx' or 'b.xxx'). Press *[Setup]* to change the colour.

Use *[Up]* and *[Down]* to adjust the intensity of the colour:

Display	Meaning
'r.000' ... 'r.255'	Red
'G.000' ... 'G.255'	Green
'b.000' ... 'b.255'	Blue

Reset to factory defaults

To reset all settings you have made to factory defaults, press [Mode] and [Setup] simultaneously for five seconds. After the reset, the unit operates in automatic mode and the display shows 'AUTO'.

7.3 Menu overview

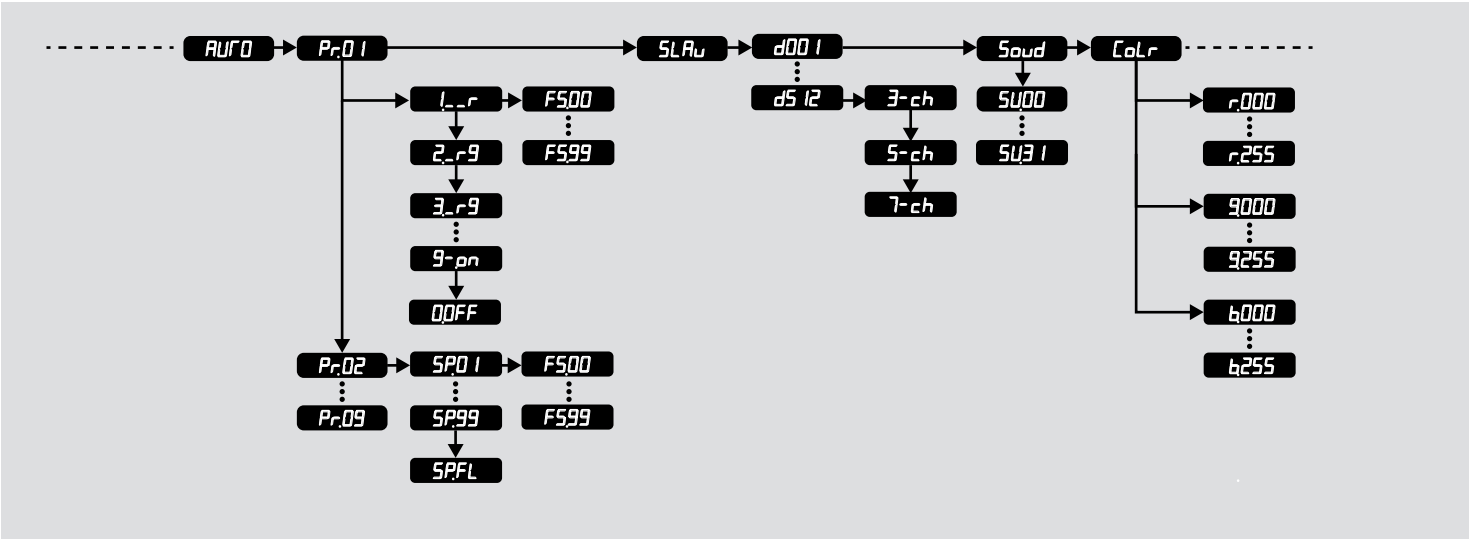

7.4 Temperature monitoring

If the temperature inside the unit becomes too high, the unit switches itself off automatically. In this case, let the unit cool down before powering it up again.

The temperature-controlled shut-off function is constantly monitored by the device. If a defect is detected, the value 'rt' is flashing in the display. In this case, please contact our service centre. Contact details can be found at www.thomann.de.

7.5 Functions in 3-channel DMX mode

Channel	Value	Function
1	0 ... 255	Intensity Red (0 % to 100 %)
2	0 ... 255	Intensity Green (0 % to 100 %)
3	0 ... 255	Intensity Blue (0 % to 100 %)

7.6 Functions in 5-channel DMX mode

Channel	Value	Function
1	0 ... 255	Intensity Red (0 % to 100 %)
2	0 ... 255	Intensity Green (0 % to 100 %)
3	0 ... 255	Intensity Blue (0 % to 100 %)
4	0 ... 255	Dimmer (0 % to 100 %)
5	0 ... 255	Strobe effect, increasing speed

7.7 Functions in 7-channel DMX mode

Channel	Value	Function
1	0...255	Dimmer (0 % to 100 %)
2	0...255	Intensity red (0 % to 100 %), when channel 5 = 0
3	0...255	Intensity green (0 % to 100 %), when channel 5 = 0
4	0...255	Intensity blue (0 % to 100 %), when channel 5 = 0
5	Operating mode	

Channel	Value	Function
	0	Manual mode; colours can be adjusted via channels 2 to 4
	1...27	Preprogrammed automatic show no. 1
	28...55	Preprogrammed automatic show no. 2
	56...83	Preprogrammed automatic show no. 3
	84...111	Preprogrammed automatic show no. 4
	112...139	Preprogrammed automatic show no. 5
	140...167	Preprogrammed automatic show no. 6
	168...195	Preprogrammed automatic show no. 7
	196...223	Preprogrammed automatic show no. 8
	224...251	Preprogrammed automatic show no. 9
	252...255	Sound-controlled show
6	Constant colour, when channel 5 = 1...24:	
	0...27	Dark
	28...55	Red
	56...83	Orange
	84...111	Yellow

Channel	Value	Function
	112...139	Light green
	140...167	Light blue
	168...195	Blue
	196...223	Purple
	224...251	Pink
	252...255	Red + green + blue
	Progress speed, when channel 5 = 25...255:	
0...255	Increasing speed	
7	0...255	Strobe effect, increasing speed

7.8 Remote control

Operating mode 'Preprogrammed automatic show'

A preprogrammed automatic show can only be activated when the unit is operating alone or as master in a master-slave combination. This setting is only relevant if the device is not controlled via DMX.

Press *[MANUAL]*. The display shows 'Pr.xx'. Now you can select one of the preprogrammed automatic shows. Use *[+]* and *[-]* to select a value between 'Pr.01' and 'Pr.09'.

Press *[SPEED]* to adjust the programme speed. The display shows 'SP.xx'. Use *[%]*, *[+]* and *[-]* to select a value between 'SP.01' (slow) and 'SP.FL' (fast).

Press *[STROBE]* to set the flash frequency. The display shows 'FS.xx'. Use *[%]*, *[+]* and *[-]* to select a value between 'FS.00' (slow) and 'FS.99' (fast).

Operating mode 'Automatic'

The automatic mode can only be activated when the unit is operating alone or as master in a master-slave combination. This setting is only relevant if the device is not controlled via DMX.

Press *[AUTO]*. The display shows 'AUTO', the playback of the built-in automatic programme starts automatically.

Sound control

The sound-controlled automatic show can only be activated when the unit is operating alone or as master in a master-slave combination. This setting is only relevant if the device is not controlled via DMX.

Press *[SOUND]*. The display shows 'SUxx', the sound-controlled automatic show is activated.

Use *[%]*, *[+]* and *[-]* to set the sensitivity for the sound control in a range between 'SV.00' and 'SV.31'.

Constant colour

A constant colour can only be activated when the unit is operating alone or as master in a master-slave combination. This setting is only relevant if the device is not controlled via DMX.

Press *[MANUAL]*. Now you can either call up a predefined colour directly with one of the coloured buttons, or mix a colour individually from the basic colours.

Press *[R]*, *[G]* or *[B]* to mix a colour individually from the basic colours. The display shows 'r.xxx', 'G.xxx' or 'b.xxx'.

Use *[%]*, *[+]* and *[-]* to set the colour intensity:

Display	Description
'r.000' ... 'r.255'	Red
'G.000' ... 'G.255'	Green
'b.000' ... 'b.255'	Blue

Blackout

Press *[BLACKOUT]* to switch the LEDs off or on again. Then the unit continues to operate in the last selected operating mode.

The Blackout function is only available when the unit is not controlled via DMX.

8 Technical specifications

		Item no. 317335	Item no. 414494
Light source		18 × RGB, 3 W	
Optical properties	Beam angle	25 °	45 °
Control	DMX		
	IR remote control		
Number of DMX channels	3, 5, 7		
Input connections	Power supply	IEC chassis plug C14	
	DMX control	XLR chassis socket, 3-pin	
Output connections	Power supply	IEC chassis socket C13	
	DMX control	XLR chassis socket, 3-pin	
Power consumption	60 W		
Supply voltage	100 - 240 V ~ 50/60 Hz		
Fuse	5 mm × 20 mm, 2 A, 250 V, slow-blow		
Battery remote control	Lithium-ion button cell CR2025, 3 V		
Degree of protection	IP20		

Technical specifications

	Item no. 317335	Item no. 414494
Mounting options	Hanging, standing	
Dimensions (W × H × D)	210 mm × 270 mm × 135 mm (without bracket)	
Weight	2.9 kg	
Ambient conditions	Temperature range	0 °C...40 °C
	Relative humidity	20 %...80 % (non-condensing)

Further information

	Item no. 317335	Item no. 414494
Design	Flat PAR	Flat PAR
Colour mixture	RGB	RGB
LED type	x-in-1	x-in-1
Base housing	yes	yes
Fanless	no	no
Wireless DMX	no	no
Housing colour	black	black

9 Plug and connection assignments

Introduction

This chapter will help you select the right cables and plugs to connect your valuable equipment so that a perfect light experience is guaranteed.

Please take our tips, because especially in 'Sound & Light' caution is indicated: Even if a plug fits into a socket, the result of an incorrect connection may be a destroyed DMX controller, a short circuit or 'just' a not working light show!

DMX connections



The unit offers a 3-pin XLR socket for DMX output and a 3-pin XLR plug for DMX input. Please refer to the drawing and table below for the pin assignment of a suitable XLR plug.

Pin	Configuration
1	Ground, shielding
2	Signal inverted (DMX-, 'cold signal')
3	Signal (DMX+, 'hot signal')

10 Troubleshooting



NOTICE!

Possible data transmission errors

For error-free operation make use of dedicated DMX cables and do not use ordinary microphone cables.

Never connect the DMX input or output to audio devices such as mixers or amplifiers.

In the following we list a few common problems that may occur during operation. We give you some suggestions for easy troubleshooting:

Symptom	Remedy
The unit does not work, no light.	Check the mains connection and the main fuse.
No response to the DMX controller.	<ol style="list-style-type: none"> 1. If the unit is in DMX mode and a DMX controller is connected and turned on, the 'd' flashes in the first position of the display. If not, no valid DMX signal is received. Check that the DMX controller is switched on. Check the DMX connectors and cables for proper connection. 2. If the display is not flashing and there is still no response, check the address settings and DMX polarity. 3. Try using another DMX controller. 4. Check to see if the DMX cables run near or alongside to high voltage cables that may cause damage or interference to DMX interface circuits.
No response to the remote control	<ol style="list-style-type: none"> 1. Try the remote control at a different angle to the receiver on the front of the device. 2. Move the remote control closer to the unit. 3. Check the remote control battery.

If the procedures recommended above do not succeed, please contact our Service Center. You can find the contact information at www.thomann.de.

11 Cleaning

Optical lenses

Clean the optical lenses, that are accessible from the outside, regularly in order to optimize the light output. The frequency of cleaning depends on the operating environment: wet, smoky or particularly dirty surroundings can cause more accumulation of dirt on the optics of the device.

- Clean with a soft cloth using our lamp and lens cleaner (item no. 280122).
- Always dry the parts carefully.

Fan grids

The fan grids of the device must be cleaned of any contamination, such as dust, etc. on a regular basis. Before cleaning, switch off the device and disconnect mains-operated devices from the mains. Only use pH-neutral, solvent-free and non-abrasive cleaning agents. Clean the unit with a slightly damp lint-free cloth.

12 Protecting the environment

Disposal of the packaging material



For the packaging, environmentally friendly materials have been chosen that can be supplied to normal recycling.

Ensure that plastic bags, packaging, etc. are properly disposed of.

Do not just dispose of these materials with your normal household waste, but make sure that they are collected for recycling. Please follow the notes and markings on the packaging.

Disposal of batteries



Batteries must not be thrown away or incinerated; they must be disposed of in accordance with local regulations for the disposal of hazardous waste. Use the existing collection points for this.

Only dispose of lithium batteries when they are discharged. Remove replaceable lithium batteries from the device before disposal. Protect used lithium batteries against short circuits, for example by covering the poles with adhesive tape. Permanently built-in lithium batteries must be disposed of together with the device. Please inquire about an appropriate collection point.

Disposal of your old device



This product is subject to the European Waste Electrical and Electronic Equipment Directive (WEEE) in its currently valid version. Do not dispose with your normal household waste.

Dispose of this device through an approved waste disposal firm or through your local waste facility. When discarding the device, comply with the rules and regulations that apply in your country. If in doubt, consult your local waste disposal facility.

