



**the**  
**box** **pro**

Achat 104 A  
active speaker

Musikhaus Thomann  
Thomann GmbH  
Hans-Thomann-Straße 1  
96138 Burgebrach  
Germany  
Telephone: +49 (0) 9546 9223-0  
E-mail: [info@thomann.de](mailto:info@thomann.de)  
Internet: [www.thomann.de](http://www.thomann.de)

02.08.2021, ID: 325264 (V3)

---

## Table of contents

<b>1</b>	<b>General information</b> .....	<b>4</b>
	1.1 Further information.....	5
	1.2 Notational conventions.....	6
	1.3 Symbols and signal words.....	6
<b>2</b>	<b>Safety instructions</b> .....	<b>9</b>
<b>3</b>	<b>Features</b> .....	<b>12</b>
<b>4</b>	<b>Installation</b> .....	<b>13</b>
	4.1 Tips on handling speakers.....	15
<b>5</b>	<b>Connections and operating elements</b> .....	<b>16</b>
<b>6</b>	<b>Technical specifications</b> .....	<b>19</b>
<b>7</b>	<b>Plug and connection assignment</b> .....	<b>23</b>
<b>8</b>	<b>Protecting the environment</b> .....	<b>26</b>

# 1 General information

This user manual contains important information on the safe operation of the device. Read and follow all safety notes and all instructions. Save this manual for future reference. Make sure that it is available to all persons using this device. If you sell the device to another user, be sure that they also receive this manual.

Our products and user manuals are subject to a process of continuous development. We therefore reserve the right to make changes without notice. Please refer to the latest version of the user manual which is ready for download under [www.thomann.de](http://www.thomann.de).

## 1.1 Further information

On our website ([www.thomann.de](http://www.thomann.de)) you will find lots of further information and details on the following points:

Download	This manual is also available as PDF file for you to download.
Keyword search	Use the search function in the electronic version to find the topics of interest for you quickly.
Online guides	Our online guides provide detailed information on technical basics and terms.
Personal consultation	For personal consultation please contact our technical hotline.
Service	If you have any problems with the device the customer service will gladly assist you.

## 1.2 Notational conventions

This manual uses the following notational conventions:

### Letterings



The letterings for connectors and controls are marked by square brackets and italics.

**Examples:** *[VOLUME]* control, *[Mono]* button.

## 1.3 Symbols and signal words

In this section you will find an overview of the meaning of symbols and signal words that are used in this manual.

Signal word	Meaning
<b>DANGER!</b>	This combination of symbol and signal word indicates an immediate dangerous situation that will result in death or serious injury if it is not avoided.
<b>WARNING!</b>	This combination of symbol and signal word indicates a possible dangerous situation that can result in death or serious injury if it is not avoided.
<b>CAUTION!</b>	This combination of symbol and signal word indicates a possible dangerous situation that can result in minor injury if it is not avoided.
<b>NOTICE!</b>	This combination of symbol and signal word indicates a possible dangerous situation that can result in material and environmental damage if it is not avoided.
Warning signs	Type of danger
	Warning – high-voltage.

Warning signs	Type of danger
 A yellow triangular warning sign with a black border. Inside the triangle, there is a black silhouette of a person standing next to a rectangular object (representing a load) that is suspended by a hook or cable.	Warning – suspended load.
 A yellow triangular warning sign with a black border. Inside the triangle, there is a large black exclamation mark.	Warning – danger zone.



## 2 Safety instructions

### Intended use

This device is designed for sound reinforcement. Use the device only as described in this user manual. Any other use or use under other operating conditions is considered to be improper and may result in personal injury or property damage. No liability will be assumed for damages resulting from improper use.

This device may be used only by persons with sufficient physical, sensorial, and intellectual abilities and having corresponding knowledge and experience. Other persons may use this device only if they are supervised or instructed by a person who is responsible for their safety.



#### **DANGER!**

##### **Danger for children**

Ensure that plastic bags, packaging, etc. are disposed of properly and are not within reach of babies and young children. Choking hazard! Ensure that children do not detach any small parts (e.g. knobs or the like) from the unit. They could swallow the pieces and choke! Never let children unattended use electrical devices.



#### **DANGER!**

##### **Electric shock caused by high voltages inside**

Within the device there are areas where high voltages may be present. Never remove any covers. There are no user-serviceable parts inside. Do not use the device if covers, protectors or optical components are missing or damaged.



### **DANGER!**

#### **Electric shock caused by short-circuit**

Always use proper ready-made insulated mains cabling (power cord) with a protective contact plug. Do not modify the mains cable or the plug. Failure to do so could result in electric shock/death or fire. If in doubt, seek advice from a registered electrician.



### **CAUTION!**

#### **Possible hearing damage**

The device can produce volume levels that may cause temporary or permanent hearing impairment. Over an extended period of time, even levels that seem to be uncritical can cause hearing damage. Decrease the volume level immediately if you experience ringing in your ears or hearing impairment. If this is not possible, keep a greater distance or use sufficient ear protectors.



### **NOTICE!**

#### **Risk of fire**

Do not block areas of ventilation. Do not install the device near any direct heat source. Keep the device away from naked flames.



### **NOTICE!**

#### **Operating conditions**

This device has been designed for indoor use only. To prevent damage, never expose the device to any liquid or moisture. Avoid direct sunlight, heavy dirt, and strong vibrations. Only operate the device within the ambient conditions specified in the chapter 'Technical specifications' of this user manual. Avoid heavy temperature fluctuations and do not switch the device on immediately after it was exposed to temperature fluctuations (for example after transport at low outside temperatures). Dust and dirt inside can damage the unit. When operated in harmful ambient conditions (dust, smoke, nicotine, fog, etc.), the unit should be maintained by qualified service personnel at regular intervals to prevent overheating and other malfunction.



**NOTICE!**

**Power supply**



Before connecting the device, ensure that the input voltage (AC outlet) matches the voltage rating of the device and that the AC outlet is protected by a residual current circuit breaker. Failure to do so could result in damage to the device and possibly injure the user. Unplug the device before electrical storms occur and when it is unused for long periods of time to reduce the risk of electric shock or fire.



**NOTICE!**

**Possible damage due to installation of a wrong fuse**



The use of different types of fuses can cause serious damage to the unit. Fire hazard! Only fuses of the same type may be used.



**NOTICE!**

**Possible staining**



The plasticiser contained in the rubber feet of this product may possibly react with the coating of your parquet, linoleum, laminate or PVC floor and after some time cause permanent dark stains. In case of doubt, do not put the rubber feet directly on the floor, but use felt-pad floor protectors or a carpet.

### 3 Features

- Active mini speaker with 4" woofers and 1" tweeter
- Including L-bracket, M6 thread
- Optional wall mount available
- Black textured paint
- Power saving mode

When the box receives no signal for 60 minutes, it switches to standby mode. As soon as the unit receives a signal, it switches automatically back to normal mode.

## 4 Installation

Unpack and check carefully there is no transportation damage before using the unit. Keep the equipment packaging. To fully protect the product against vibration, dust and moisture during transportation or storage use the original packaging or your own packaging material suitable for transport or storage, respectively.

Create all connections while the device is off. Use the shortest possible high-quality cables for all connections. Take care when running the cables to prevent tripping hazards.



### **WARNING!**

#### **Risk of injury caused by falling objects**

Make sure that the installation complies with the standards and rules that apply in your country. Always secure the device with a secondary safety attachment, such as a safety cable or a safety chain.



### **NOTICE!**

#### **Possible property damage by magnetic fields**

Loudspeakers produce a static magnetic field. Therefore, maintain an appropriate distance to devices that can be adversely affected or damaged by an external magnetic field.



### **NOTICE!**

#### **Use of stands**

When mounting the device onto a stand, ensure that the stand is in a safe and stable position and that the weight of the device does not exceed the maximum permissible load capacity of the stand.

## 4.1 Tips on handling speakers

We recommend you to set up the speakers in a way, that the sound signals can reach the audience unobstructedly. It will often be helpful to mount the speakers on tripods. Thus, the sound will be evenly spread with maximum range throughout the audience area.

Always use high grade cable to connect your equipment. Otherwise you won't reach maximum sound quality.

If you notice distortion during operation, the active speaker is overloaded. This may permanently damage the device. Always reduce the volume as soon as you hear distortion.

## 5 Connections and operating elements

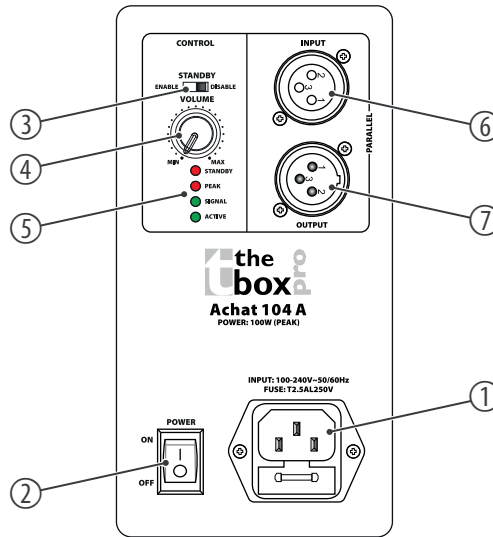



1	<p>Connection for the supply voltage IEC chassis plug for power supply with fuse holder</p>
2	<p><i>[POWER ON/OFF]</i> Use this switch (power switch) to turn the unit on and off.</p>
3	<p><i>[DISABLE/ENABLE]</i> Slide switch to enable or disable the power saving mode. If the speaker box is in power save mode and receives no signal for 60 minutes, it switches to standby mode. As soon as the unit receives a signal, it switches automatically back to normal mode.</p>
4	<p><i>[VOLUME]</i> Volume control</p>
5	<p><i>[STANDBY]</i> Standby operation. This LED lights up when the box – on activated power save mode – switches to Standby mode and turns off when the box is switched back to normal operation.</p>
	<p><i>[PEAK]</i> Indicates overload. If the LED flickers or is lit, the input signal level is too high.</p>

	<p><i>[SIGNAL]</i></p> <p>Indicates that an input signal is present.</p>
	<p><i>[ACTIVE]</i></p> <p>Power indicator. This LED lights up continuously in normal operation and turns off when the box – on activated power save mode – switches to standby mode.</p>
6	<p><i>[INPUT]</i></p> <p>Line signal input designed as XLR chassis socket</p>
7	<p><i>[OUTPUT]</i></p> <p>Line output for connecting further speakers, designed as XLR plug</p>

## 6 Technical specifications

Speaker	1 × 4" woofer, 1 × 1" textile dome tweeter	
Input connections	LINE IN	1 × XLR chassis socket
	Power supply	IEC chassis plug C14
Input impedance	XLR socket: 20 kΩ (balanced), 10 kΩ (unbalanced)	
Output connections	LINE OUT	1 × XLR chassis plug
Output power	RMS: 50 W	
	Peak: 100 W	
Frequency range	100 Hz ... 20 kHz	
Crossover frequency	1,8 kHz	
Signal-to-noise ratio	Woofer: ≥85 dB	
	Tweeter: ≥80 dB	

## Technical specifications

---

Sound pressure level (SPL), max.	109 dB	
Dispersion angle (H × V)	90° × 90°	
Power consumption	3.5 W	
Supply voltage	100 - 240 V ~ 50/60 Hz	
Fuse	5 mm × 20 mm, 2 A, 250 V, slow-blow	
Dimensions (W × H × D)	144 mm × 214 mm × 146 mm	
Weight	2.5 kg	
Ambient conditions	Temperature range	0 °C...40 °C
	Relative humidity	20 %...80 % (non-condensing)

**Further information**

Ways	2-way
Monitor inclination	No
Simultaneous inputs	1
Mic Preamps	0
Channel tone per channel	No
Bluetooth Play	No
USB player	No
Low Cut	No
Fan	No
Housing	Wood
Colour	Black

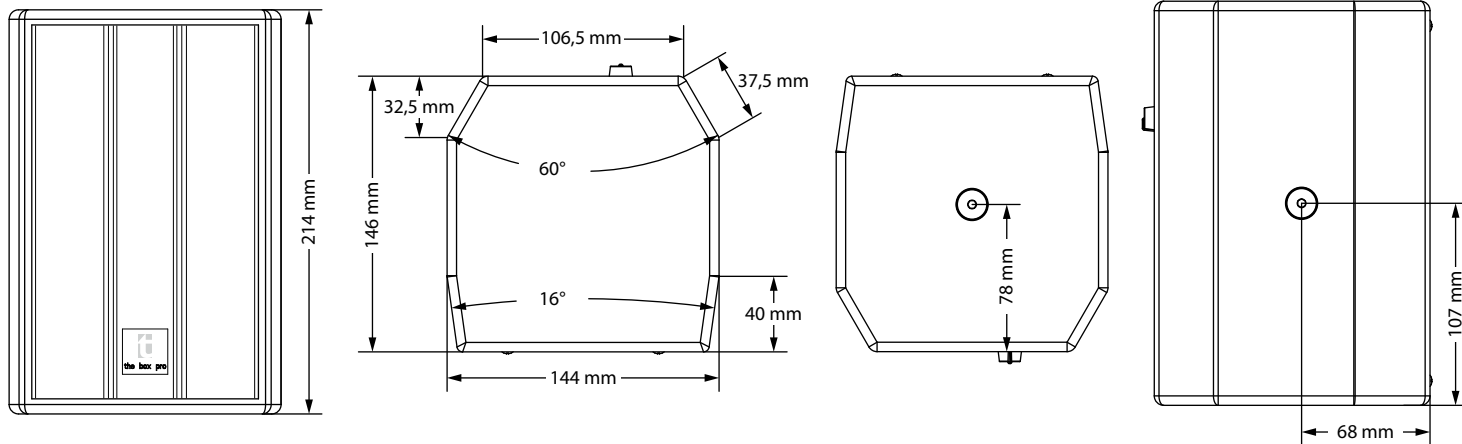

## 7 Plug and connection assignment

### Introduction

This chapter will help you select the right cables and plugs to connect your valuable equipment in such a way that a perfect sound experience is ensured.

Please note these advices, because especially in 'Sound & Light' caution is indicated: Even if a plug fits into the socket, an incorrect connection may result in a destroyed power amp, a short circuit or 'just' in poor transmission quality!

### Balanced and unbalanced transmission

Unbalanced transmission is mainly used in semi-professional environment and in hifi use. Instrument cables with two conductors (one core plus shielding) are typical representatives of the unbalanced transmission. One conductor is ground and shielding while the signal is transmitted through the core.

Unbalanced transmission is susceptible to electromagnetic interference, especially at low levels, such as microphone signals and when using long cables.

In a professional environment, therefore, the balanced transmission is preferred, because this enables an undisturbed transmission of signals over long distances. In addition to the conductors 'Ground' and 'Signal', in a balanced transmission a second core is added. This also transfers the signal, but phase-shifted by 180°.

Since the interference affects both cores equally, by subtracting the phase-shifted signals, the interfering signal is completely neutralized. The result is a pure signal without any noise interference.

### XLR plug (balanced)

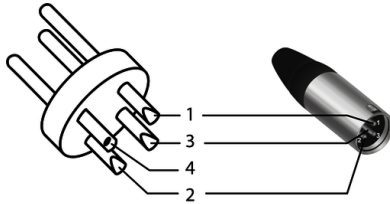

1	Ground, shielding
2	Signal (in phase, +)
3	Signal (out of phase, -)
4	Shielding on plug housing (option)



**XLR plug (unbalanced)**

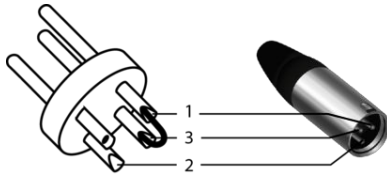

1	Ground, shielding
2	Signal
3	Bridged to pin 1

## 8 Protecting the environment

### Disposal of the packaging material



For the transport and protective packaging, environmentally friendly materials have been chosen that can be supplied to normal recycling.

Ensure that plastic bags, packaging, etc. are properly disposed of.

Do not just dispose of these materials with your normal household waste, but make sure that they are collected for recycling. Please follow the notes and markings on the packaging.

### Disposal of your old device



This product is subject to the European Waste Electrical and Electronic Equipment Directive (WEEE) in its currently valid version. Do not dispose with your normal household waste.

Dispose of this device through an approved waste disposal firm or through your local waste facility. When discarding the device, comply with the rules and regulations that apply in your country. If in doubt, consult your local waste disposal facility.



Musikhaus Thomann · Hans-Thomann-Straße 1 · 96138 Burgebrach · Germany · [www.thomann.de](http://www.thomann.de)