

FS-x75
LED Follow Spot DMX
follow spot

Musikhaus Thomann
Thomann GmbH
Hans-Thomann-Straße 1
96138 Burgebrach
Germany
Telephone: +49 (0) 9546 9223-0
E-mail: info@thomann.de
Internet: www.thomann.de

13.08.2015, ID: 333373

Table of contents

1	General information	5
	1.1 Further information.....	6
	1.2 Notational conventions.....	7
	1.3 Symbols and signal words.....	7
2	Safety instructions	10
3	Features	15
4	Installation	16
5	Starting up	20
6	Connections and operating elements	22
7	Operating	29
	7.1 Main menu.....	29
	7.2 Functions in DMX mode.....	31
8	Technical specifications	33
9	Plug and connection assignments	34

10	Troubleshooting.....	35
11	Cleaning.....	37
12	Protecting the environment.....	38

1 General information

This manual contains important instructions for the safe operation of the unit. Read and follow the safety instructions and all other instructions. Keep the manual for future reference. Make sure that it is available to all those using the device. If you sell the unit please make sure that the buyer also receives this manual.

Our products are subject to a process of continuous development. Thus, they are subject to change.

1.1 Further information

On our website (www.thomann.de) you will find lots of further information and details on the following points:

Download	This manual is also available as PDF file for you to download.
Keyword search	Use the search function in the electronic version to find the topics of interest for you quickly.
Online guides	Our online guides provide detailed information on technical basics and terms.
Personal consultation	For personal consultation please contact our technical hotline.
Service	If you have any problems with the device the customer service will gladly assist you.

1.2 Notational conventions

This manual uses the following notational conventions:

Letterings

The letterings for connectors and controls are marked by square brackets and italics.

Examples: *[VOLUME]* control, *[Mono]* button.



Displays

Texts and values displayed on the device are marked by quotation marks and italics.

Examples: *'24ch'*, *'OFF'*.

1.3 Symbols and signal words

In this section you will find an overview of the meaning of symbols and signal words that are used in this manual.

Signal word	Meaning
DANGER!	This combination of symbol and signal word indicates an immediate dangerous situation that will result in death or serious injury if it is not avoided.
WARNING!	This combination of symbol and signal word indicates a possible dangerous situation that can result in death or serious injury if it is not avoided.
NOTICE!	This combination of symbol and signal word indicates a possible dangerous situation that can result in material and environmental damage if it is not avoided.
Warning signs	Type of danger
	Warning – high-voltage.
	Warning – suspended load.

Warning signs	Type of danger
	Warning – danger zone.

2 Safety instructions

Intended use

This device is intended to be used as an electronic illumination effect using LED technics. The device is designed for professional use and is not suitable for use in households. Use the device only as described in this user manual. Any other use or use under other operating conditions is considered to be improper and may result in personal injury or property damage. No liability will be assumed for damages resulting from improper use.

This device may be used only by persons with sufficient physical, sensorial, and intellectual abilities and having corresponding knowledge and experience. Other persons may use this device only if they are supervised or instructed by a person who is responsible for their safety.

Safety



DANGER!

Danger for children

Ensure that plastic bags, packaging, etc. are disposed of properly and are not within reach of babies and young children. Choking hazard!

Ensure that children do not detach any small parts (e.g. knobs or the like) from the unit. They could swallow the pieces and choke!

Never let children unattended use electrical devices.



DANGER!

Electric shock caused by high voltages inside

Within the device there are areas where high voltages may be present. Never remove any covers.

There are no user-serviceable parts inside.



DANGER!

Electric shock caused by short-circuit

Always use proper ready-made insulated mains cabling (power cord) with a protective contact plug. Do not modify the mains cable or the plug. Failure to do so could result in electric shock/death or fire. If in doubt, seek advice from a registered electrician.



WARNING!

Eye damage caused by high light intensity

Never look directly into the light source.



WARNING!

Risk of epileptic shock

Strobe lighting can trigger seizures in photosensitive epilepsy. Sensitive persons should avoid looking at strobe lights.



NOTICE!

Risk of fire

Do not cover the device nor any ventilation slots. Do not place the device near any direct heat source. Keep the device away from naked flames.



NOTICE!

Operating conditions

This device has been designed for indoor use only. To prevent damage, never expose the device to any liquid or moisture. Avoid direct sunlight, heavy dirt, and strong vibrations.



NOTICE!

Power supply

Before connecting the device, ensure that the input voltage (AC outlet) matches the voltage rating of the device and that the AC outlet is protected by a residual current circuit breaker. Failure to do so could result in damage to the device and possibly injure the user.

Unplug the device before electrical storms occur and when it is unused for long periods of time to reduce the risk of electric shock or fire.

3 Features

The follow spot is particularly suitable for professional lighting tasks, for example at events, on rock stages, in theatres and musicals or in discotheques.

Special features of the device:

- Control via DMX (3 channels) and via buttons and display on the unit
- 8 colours directly selectable
- Electronic dimmer
- Mechanical focus
- Shutter frequency: 0...20 Hz
- Removable colour filter frame

4 Installation

Unpack and carefully check that there is no transportation damage before using the unit. Keep the equipment packaging. To fully protect the device against vibration, dust and moisture during transportation or storage use the original packaging or your own packaging material suitable for transport or storage, respectively.

You can install the unit on a follow spot tripod, on the ceiling or a crossbeam. Mounting bracket included.



WARNING!

Risk of injury caused by falling objects

Make sure that the installation complies with the standards and rules that apply in your country. Always secure the device with a secondary safety attachment, such as a safety cable or a safety chain.



NOTICE!

Risk of overheating

Always ensure sufficient ventilation.

The ambient temperature must always be below 40 °C (104 °F).



NOTICE!

Use of stands

When mounting the device onto a stand, ensure that the stand is in a safe and stable position and that the weight of the device does not exceed the maximum permissible load capacity of the stand.



NOTICE!

Possible data transmission errors

For error-free operation make use of dedicated DMX cables and do not use ordinary microphone cables.

Never connect the DMX input or output to audio devices such as mixers or amplifiers.



Please note that this device must not be connected to a dimmer.

Colour filter

The removable colour filter frame allows you to attach a colour foil as a colour filter on the unit. This lets you realise all desired colours. Suitable colour foils can be found in our Cyberstore (www.thomann.de).

To insert a colour foil, turn the power off first. Unscrew the thumbscrew (2) completely and pull the colour filter frame upwards out of the device. Clamp the properly tailored colour foil (about 115 mm × 115 mm) between the two plates of the frame and slide the frame back into the machine. Fix the colour filter frame, then tighten the thumbscrew.

5 Starting up

Establish all connections as long as the unit is switched off. Use the shortest possible high-quality cables for all connections.

Connections in DMX mode

Connect the DMX input of the device to the DMX output of a DMX controller or another DMX device. Connect the output of the first DMX device to the input of the second one, and so on to form a daisy chain. Always ensure that the output of the last DMX device in the daisy chain is terminated with a resistor ($110\ \Omega$, $\frac{1}{4}\text{ W}$).

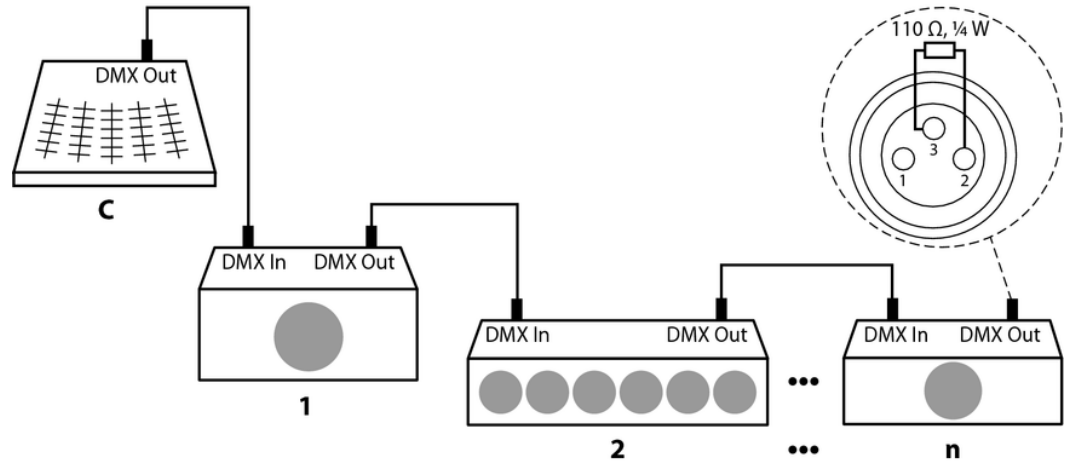

6 Connections and operating elements

Righthand view

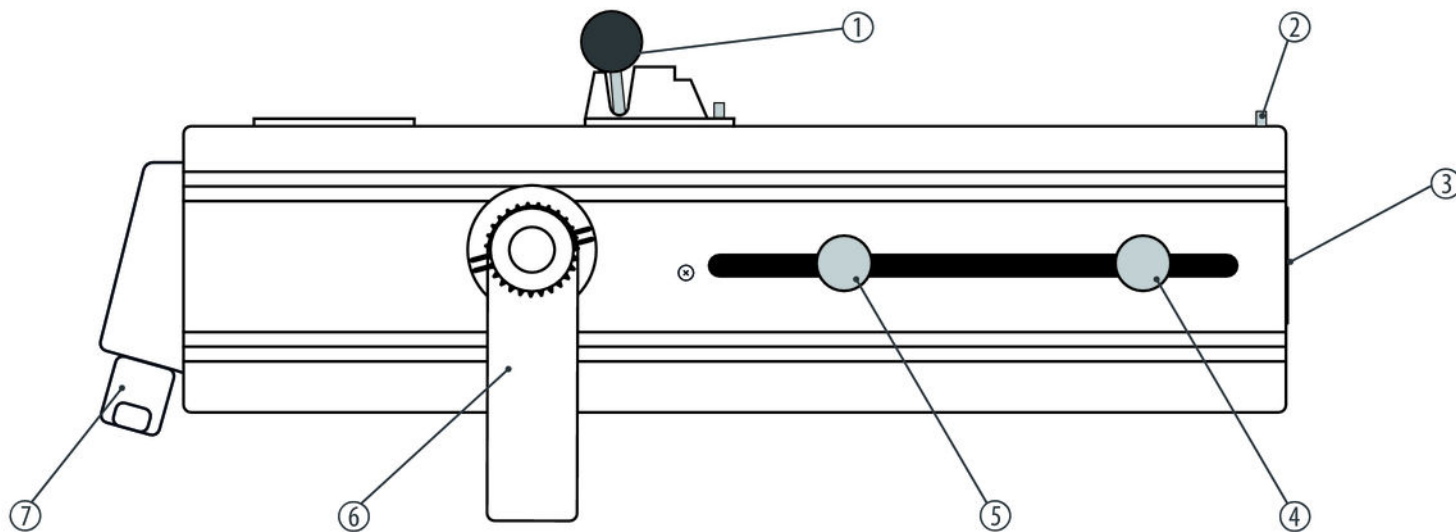

1	Lever for adjusting the iris. This lets you adjust the diameter of the light beam steplessly.
2	Fixing screw for the removable colour frame.
3	Light exit.
4	Fixable lever for shifting the lens lengthways along the optical axis. This sets the edge of the light beam sharp or soft.
5	Fixable lever for shifting the circular aperture lengthways along the optical axis. Use this lever to focus or widen the light beam.
6	Steplessly adjustable mounting bracket for installing the unit on a follow spot tripod stand. The bracket can be mounted rotated by 180 degrees to attach the unit to the ceiling or a crossbeam.
7	Swivel bracket.

Lefthand view

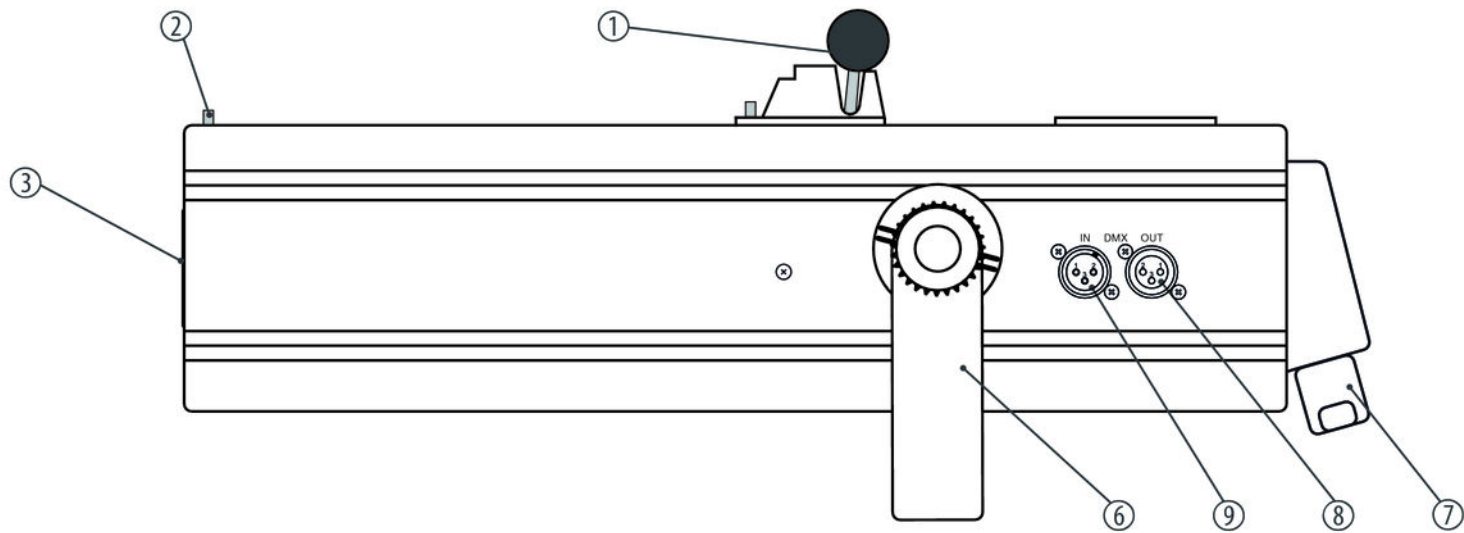

1	Lever for adjusting the iris. This lets you adjust the diameter of the light beam steplessly.
2	Fixing screw for the removable colour frame.
3	Light exit.
6	Steplessly adjustable mounting bracket for installing the unit on a follow spot tripod stand. The bracket can be mounted rotated by 180 degrees to attach the unit to the ceiling or a crossbeam.
7	Swivel bracket.
8	<i>[DMX OUT]</i> DMX output.
9	<i>[DMX IN]</i> DMX input.

Rear panel

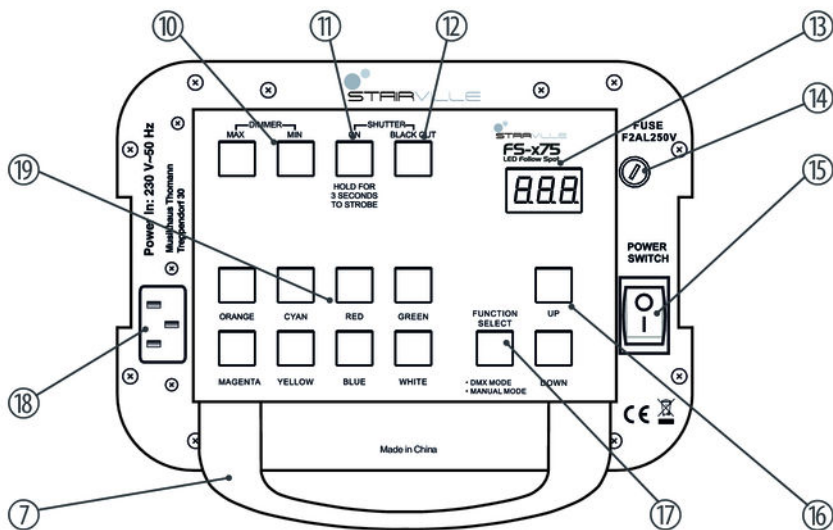

10	Buttons <i>[DIMMER MAX]</i> , <i>[DIMMER MIN]</i> Increase or decrease the brightness.
11	Button <i>[SHUTTER ON]</i> A short key press opens the shutter when the unit was blackouted before. Press the button for about three seconds to turn on the strobe effect. A short key press turns the strobe effect off again.
12	Button <i>[SHUTTER BLACK OUT]</i> Blackouts the unit.
13	Display.
14	Fuse holder.
15	<i>[POWER SWITCH]</i> Main switch. Turns the device on and off.
16	Buttons <i>[UP]</i> , <i>[DOWN]</i> To increase / decrease the displayed value by one.

17	Button <i>[FUNCTION SELECT]</i> Toggles the mode between direct operation on the unit and DMX control.
18	<i>[POWER IN]</i> IEC chassis plug for the power cable. Beneath, the range of the allowable operating voltage is specified.
19	Buttons <i>[ORANGE], [CYAN], [RED], [GREEN], [MAGENTA], [YELLOW], [BLUE], [WHITE]</i> Selects one of the seven preset colours or white from the colour wheel.

7 Operating

7.1 Main menu

Starting the device

Connect the device to the power grid. Switch the unit on with the main switch to start operation. After a few seconds, the fan starts and the display indicates that a reset is in progress. The device is then ready for use.

Press *[FUNCTION SELECT]* to activate the main menu and select an operating mode.

Direct control

Repeatedly press *[FUNCTION SELECT]* until the display shows 'Nan'. The device is now in manual mode and can no longer be controlled via DMX.

Use the buttons *[DIMMER MAX]* or *[DIMMER MIN]* to set the brightness. The display shows the set brightness in percent between '0' and '100'.

You can directly set the colour of the light beam using the buttons *[ORANGE]*, *[CYAN]*, *[RED]*, *[GREEN]*, *[MAGENTA]*, *[YELLOW]*, *[BLUE]*, *[WHITE]*. This will rotate the built-in colour wheel to the corresponding position.

Use the button *[SHUTTER BLACK OUT]* to blackout the unit without altering other settings. Press *[SHUTTER ON]* briefly to return to the previous light mood.

Press *[SHUTTER ON]* about three seconds to turn the strobe effect on. A short key press turns the strobe effect off again.

DMX mode

Repeatedly press *[FUNCTION SELECT]* until the display shows 'dxxx'. The device is now in DMX mode and can no longer be controlled using the buttons.

You can set the number of the first DMX channel to be used by the device (DMX address). Use *[UP]* and *[DOWN]* to select a value between 1 and 512. The set value is applied automatically. Make sure that this number matches the configuration of your DMX controller.

The set value is retained when the power is turned off.

7.2 Functions in DMX mode

Channel	Value	Function
1	0...255	Dimmer (0 %...100 %)
2	Colour selection	
	0...31	White
	32...63	Dark blue
	64...95	Yellow
	96...127	Magenta
	128...159	Green
	160...191	Red
	192...223	Cyan
	224...255	Orange
3	Shutter	

Channel	Value	Function
	0...3	Closed (blackout)
	4...7	Open
	8...215	Strobe effect, increasing speed
	216...255	Open

8 Technical specifications

Number of DMX channels	3
LED module	75 W
Operating supply voltage	AC 230 V ~, 50 Hz
Power consumption	120 W
Fuse	5 mm × 20 mm, 2 A, 250 V, fast-acting
Dimensions (W × D × H)	200 mm × 565 mm × 190 mm
Weight	7.6 kg

9 Plug and connection assignments

Introduction

This chapter will help you select the right cables and plugs to connect your valuable equipment so that a perfect light experience is guaranteed.

Please take our tips, because especially in 'Sound & Light' caution is indicated: Even if a plug fits into a socket, the result of an incorrect connection may be a destroyed DMX controller, a short circuit or 'just' a not working light show!

DMX connections

The unit offers a 3-pin XLR socket for DMX output and a 3-pin XLR plug for DMX input. Please refer to the drawing and table below for the pin assignment of a suitable XLR plug.



Pin	Configuration
1	Ground, shielding
2	Signal inverted (DMX-, 'cold signal')
3	Signal (DMX+, 'hot signal')

10 Troubleshooting



NOTICE!

Possible data transmission errors

For error-free operation make use of dedicated DMX cables and do not use ordinary microphone cables.

Never connect the DMX input or output to audio devices such as mixers or amplifiers.

In the following we list a few common problems that may occur during operation. We give you some suggestions for easy troubleshooting:

Symptom	Remedy
The unit does not work, no light, the fan does not run	Check the mains connection and the main fuse.
No response to the DMX controller	1. Check the DMX connectors and cables for proper connection.
	2. Check the address settings and the DMX polarity.
	3. Try using another DMX controller.
	4. Check to see if the DMX cables run near or alongside to high voltage cables that may cause damage or interference to DMX interface circuits.

If the procedures recommended above do not succeed, please contact our Service Center. You can find the contact information at www.thomann.de.

11 Cleaning

Optical lenses

Clean the optical lenses, that are accessible from the outside, regularly in order to optimize the light output. The frequency of cleaning depends on the operating environment: wet, smoky or particularly dirty surroundings can cause more accumulation of dirt on the optics of the device.

- Clean with a soft cloth using our lamp and lens cleaner (item no. 280122).
- Always dry the parts carefully.

Fan grids

The fan grids of the device must be cleaned on a regular basis to remove dust and dirt. Before cleaning, switch off the device and disconnect AC-powered devices from the mains. Use a lint-free damp cloth for cleaning. Never use solvents or alcohol for cleaning.

12 Protecting the environment

Disposal of the packaging material



For the transport and protective packaging, environmentally friendly materials have been chosen that can be supplied to normal recycling.

Ensure that plastic bags, packaging, etc. are properly disposed of.

Do not just dispose of these materials with your normal household waste, but make sure that they are collected for recycling. Please follow the notes and markings on the packaging.

Disposal of your old device



This product is subject to the European Waste Electrical and Electronic Equipment Directive (WEEE). Do not dispose with your normal household waste.

Dispose of this device through an approved waste disposal firm or through your local waste facility. When discarding the device, comply with the rules and regulations that apply in your country. If in doubt, consult your local waste disposal facility.



