



SYRINCS

S3A, S4A
User manual



Musikhaus Thomann

Thomann GmbH

Hans-Thomann-Straße 1

96138 Burgebrach

Germany

Telephone: +49 (0) 9546 9223-0

E-mail: info@thomann.de

Internet: www.thomann.de

22.03.2016

Issue 1



Table of contents

1	General information about this manual	4
2	For your safety	5
3	Features	8
4	Installation	9
5	Connections and controls	11
6	Technical specifications	14
7	Plug and connection assignment	17
8	Protecting the environment	20



1 General information about this manual

This user manual contains important instructions for the safe operation of the unit. Read and follow the safety instructions and all other instructions. Keep the manual for future reference. Make sure that it is available to all those using the device. If you sell the unit, please make sure that the buyer also receives this manual.



Our products are subject to a process of continuous development. Thus, they are subject to change.

Signal words used

All precautions in this manual are clearly highlighted. The following signal words are used for precautions:

DANGER	This warns of dangers that can result in severe injuries or death if the instructions are not followed.
WARNING	This warns of dangers that can result in severe injuries or death and/or cause considerable material damage if the instructions are not followed.
CAUTION	This warns of dangers that can result in reversible injuries and/or considerable material damage if the instructions are not followed.
NOTICE	This warns of dangers that can result to faults during operation and/or considerable material damage. Environmental damage may also occur if the instructions are not followed.

Symbols used

	General warning of a dangerous location
	Notice



2 For your safety

Intended use

This device is designed as a PA system. Use the device only as described in this user manual. Any other use or use under other operating conditions is considered to be improper and may result in personal injury or property damage. No liability will be assumed for damages resulting from improper use.

This device may be used only by persons with sufficient physical, sensorial, and intellectual abilities and having corresponding knowledge and experience. Other persons may use this device only if they are supervised or instructed by a person who is responsible for their safety.

Safety instructions



DANGER

Danger for children

Ensure that plastic bags, packaging, etc. are properly disposed of and are not in the reach of babies and young children. Choking hazard!

- Ensure that children do not detach any small parts (e.g. knobs or the like) from the product. They could swallow the pieces and choke!
- Never let children play unattended with the electrical devices.



DANGER

Electric shock caused by high voltages inside

Within the device there are areas where high voltages may be present.

- Never remove any covers. There are no user-serviceable parts inside.



DANGER

Electric shock caused by short circuit

- Always use properly insulated, tripe-core mains cable. Do not modify the mains cable. Failure to do so may result in electric shock and lead to a fire hazard and risk of death. If in doubt, seek advice from a registered electrician.



CAUTION

Possible hearing damage

The device can produce volume levels that may cause temporary or permanent hearing impairment. Over an extended period of time, even levels that seem to be uncritical can cause hearing damage.

- Decrease the volume level immediately if you experience ringing in your ears or hearing impairment. If this is not possible, keep a greater distance or use sufficient ear protectors.



NOTICE

Operating conditions

This device has been designed for indoor use only.

- To prevent damage, never expose the device to any liquid or moisture. Avoid direct sunlight, heavy dirt, and strong vibrations.



NOTICE

Power supply

- Before connecting the device, ensure that the input voltage (AC outlet) matches the voltage rating of the device and that the AC outlet is protected by a residual current circuit breaker. Failure to do so could result in damage to the device and possibly the user.
 - Unplug the device before electrical storms occur and when it is unused for long periods of time to reduce the risk of electric shock or fire.
-



3 Features

Special features of this active 2-way, full-range speaker:

- XLR/1/4" jack combo-socket and RCA installation socket for signal input
- XLR chassis connector for signal output
- Integrated digital amplifier with sound processor (DSP)
- Setting options and display for delay time and volume
- Switchable pattern for adapting to operating mode, set-up arrangement and type of presentation
- Power supply via locking powerCON input
- Multiplex housing
- Fixture on the bottom for SM 707 rotating, tilting speaker flange from Adam Hall
- Two M10 threaded attachment points for flying bracket mounting on the top



4 Installation

Unpack the device and check carefully that there is no transportation damage before using the unit. Keep the equipment packaging. To fully protect the product against vibration, dust and moisture during transportation or storage use the original packaging or your own packaging material suitable for transport or storage, respectively.

Create all connections while the device is off. Use the shortest possible high-quality cables for all connections.



NOTICE

Possible property damage by magnetic fields

Loudspeakers produce a static magnetic field.

→ Therefore maintain an appropriate distance to devices that can be adversely affected or damaged by an external magnetic field.



NOTICE

Use of stands

→ When mounting the device onto a stand, ensure that the stand is in a safe and stable position and that the weight of the device does not exceed the maximum permissible load capacity of the stand.

We recommend you to set up the speakers in a way, that their sound signals can reach the audience unobstructedly. It will often be helpful to mount the speakers on tripods. Thus, the sound will be evenly spread with maximum range throughout the audience area.

Always use high grade cables to connect your equipment. Otherwise you won't reach maximum sound quality.

For optimum results both impedance and power rating of the speaker must match the requirements of the amplifier / input signal. Consider the technical specifications of the speakers connected. The overall impedance of the con-



nected loudspeakers shall not be less than the minimum output impedance of the amp. The amps max. RMS output power should be 50 % above the power handling capacity of the connected speakers.

If you notice distortion during operation, either the amp or the speaker is overloaded. This may permanently damage the amp or the speaker. Always reduce the volume as soon as you notice distortion.



5 Connections and controls

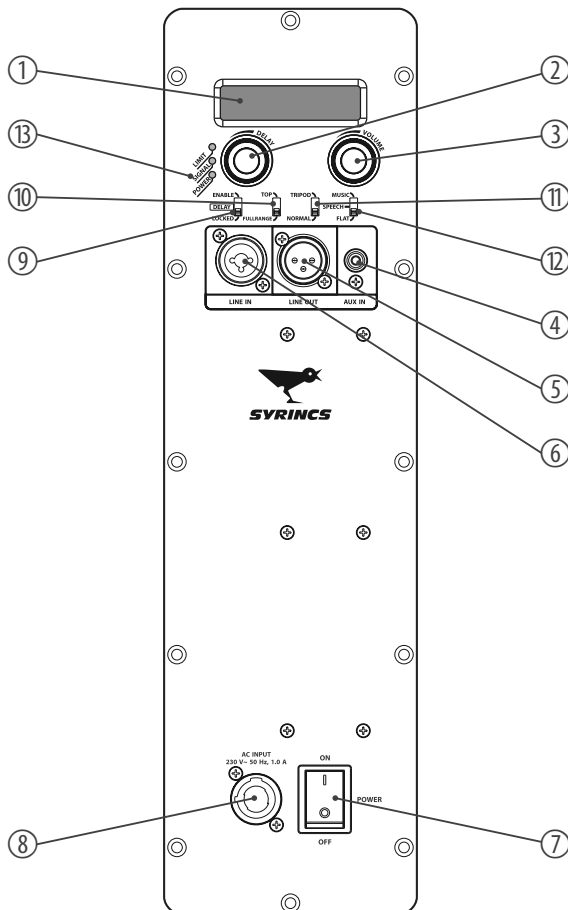



1	Display. Shows the set values for delay time, crossover frequency and volume.
2	<i>DELAY</i> Control for adjusting delay time. This allows you to balance out time differences when speakers are arranged at an offset.
3	<i>VOLUME</i> Volume control.
4	<i>AUX IN</i> Signal input for additional audio devices like MP3 or CD players.
5	<i>LINE OUT</i> Line output for connecting further speakers, designed as XLR chassis plug.
6	<i>LINE IN</i> Line signal input, designed as XLR / 1/4" combo socket.
7	<i>POWER</i> Main switch. Turns the device on and off.
8	<i>AC INPUT</i> Power supply input powerCON (NAC3FA).
9	<i>DELAY</i> Switch for locking delay time setting. In the <i>ENABLE</i> position, the delay time can be set using the <i>DELAY</i> (2) control. In the <i>DISABLE</i> position, the last delay time set is maintained.
10	Switch for operating mode selection. Select <i>TOP</i> mode if the speaker box is to be used as the top part and operated in conjunction with a subwoofer. If the speaker box is to be used by itself, select <i>FULLRANGE</i> mode.



Connections and controls

11	Switch for adapting the pattern to the set-up arrangement. Select <i>TRIPOD</i> if the speaker box is positioned on a tripod and <i>NORMAL</i> for all other set-up arrangements.
12	Switch for adjusting the sound. <ul style="list-style-type: none">– <i>MUSIC</i>: for musical presentations, base tones are emphasized.– <i>SPEECH</i>: for speech recordings, mids are highlighted.– <i>FLAT</i>: for uniform playback of all frequencies.
13	Control LEDs <ul style="list-style-type: none">– <i>LIMIT</i>: The red LED indicates that the limiter has been triggered.– <i>SIGNAL</i>: The green LED indicates that a signal is present at the input.– <i>POWER</i>: The green LED lights up when the device is turned on.



6 Technical specifications

S3A

Configuration	10" woofer 1" tweeter
Power handling	450 W (RMS)
Maximal sound pressure	121 dB (1 m) 127 dB (peak)
Frequency range	90 Hz ... 20 kHz (-3 dB)
Dimensions (W × H × D)	310 mm × 460 mm × 295 mm
Weight	12 kg

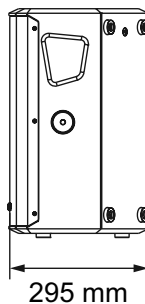
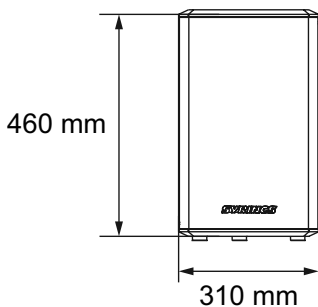
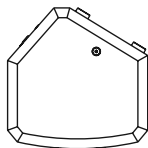



S4A

Configuration	12" woofer 1.4" tweeter
Power handling	1000 W (RMS)
Maximal sound pressure	123 dB (1 m) 129 dB (peak)
Frequency range	70 Hz ... 20 kHz (-3 dB)
Dimensions (W × H × D)	360 mm × 620 mm × 355 mm
Weight	21 kg

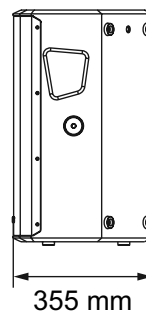
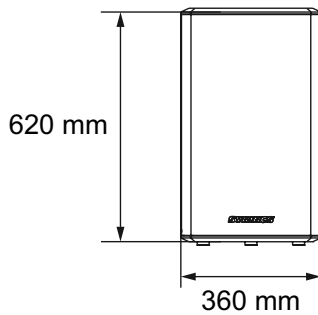
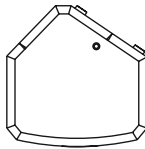



Frequency response S3A

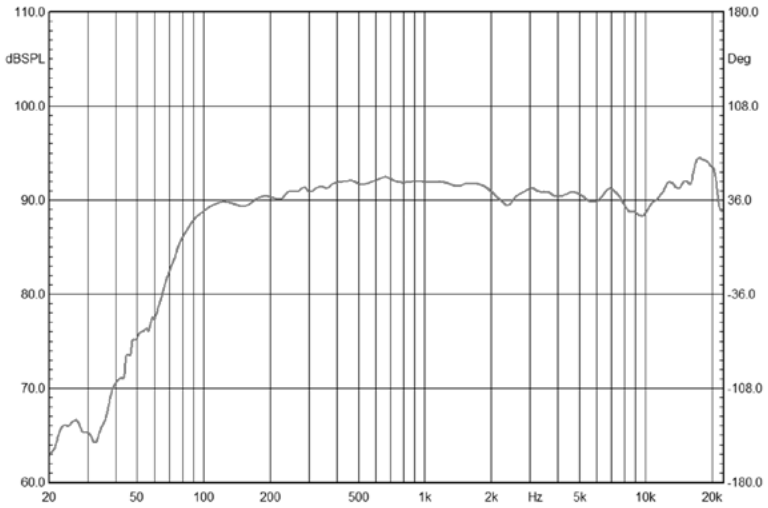

Frequency response S4A

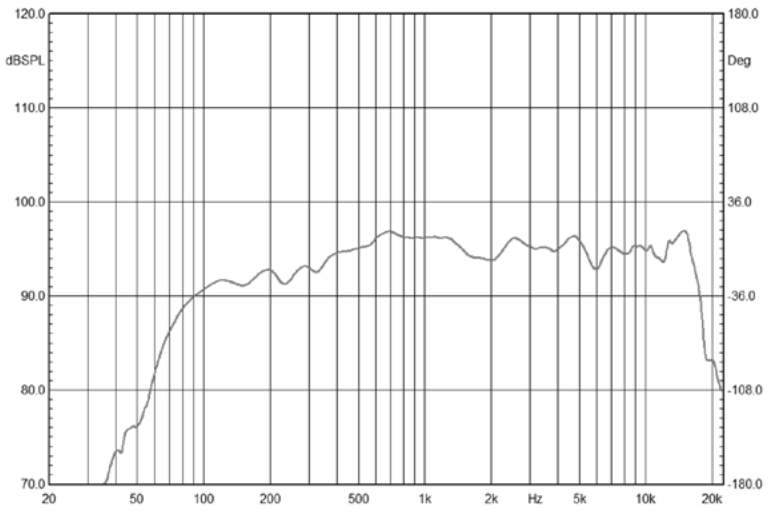



7 Plug and connection assignment

Introduction

This chapter will help you select the right cables and plugs to connect your valuable equipment in such a way that a perfect sound experience is ensured.

Please follow these tips, because special care is required when dealing with sound and light: Even if a plug fits into the socket, an incorrect connection may result in a destroyed power amp, a short circuit or just in poor transmission quality!

Balanced and unbalanced transmission

Unbalanced transmission is mainly used in semi-professional environment and in Hi-Fi use. Instrument cables with two conductors (one core plus shielding) are typical representatives of the unbalanced transmission. One conductor is ground and shielding while the signal is transmitted through the core.

Unbalanced transmission is susceptible to electromagnetic interference, especially at low levels, such as microphone signals and when using long cables.

In a professional environment, therefore, the balanced transmission is preferred, because this enables an undisturbed transmission of signals over long distances. In addition to the conductors 'Ground' and 'Signal', in a balanced transmission a second core is added. This also transfers the signal, but phase-shifted by 180°.

Since the interference affects both cores equally, by subtracting the phase-shifted signals, the interfering signal is completely neutralized. The result is a pure signal without any noise interference.

1/4" TS phone plug (mono, unbalanced)

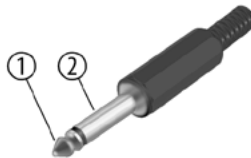

1	Signal
2	Ground



1/4" TRS phone plug (mono, balanced)

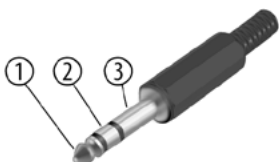

1	Signal (in phase, +)
2	Signal (out of phase, -)
3	Ground

XLR connector (balanced)

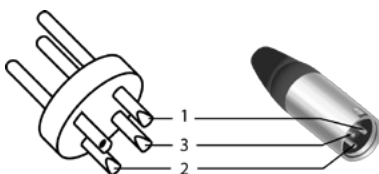

1	Ground, shielding
2	Signal (in phase, +)
3	Signal (out of phase, -)



XLR connector (unbalanced)

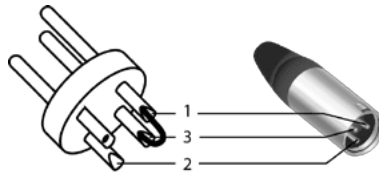

1	Ground, shielding
2	Signal
3	Jumpered with pin 1

RCA connections

The figure and the table show the pin assignment of an RCA connector.

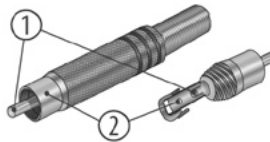

1	Signal
2	Ground



8 Protecting the environment

Packaging



For the packaging, environmentally friendly materials have been chosen that can be supplied to normal recycling. Ensure that plastic bags, packaging, etc. are properly disposed of.

Do not just dispose of these materials with your normal household waste, but make sure that they are collected for recycling. Please follow the notes and markings on the packaging.

Disposal of your old device



This product is subject to the European Waste Electrical and Electronic Equipment Directive (WEEE) in its currently valid version. Do not dispose with your normal household waste.

Dispose of this device through an approved waste disposal firm or through your local waste facility. When discarding the device, comply with the rules and regulations that apply in your country. If in doubt, consult your local waste disposal facility.



Notes





Notes

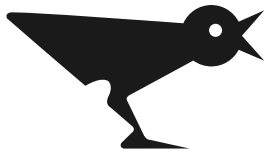

SYRINCS