



xBrick Quad 16×8W RGBW

LED Floodlight

Thomann GmbH

Hans-Thomann-Straße 1

96138 Burgebrach

Germany

Telephone: +49 (0) 9546 9223-0

Internet: www.thomann.de

29.07.2022, ID: 385641 (V4)

Table of contents

1	General information	6
	1.1 Further information.....	7
	1.2 Notational conventions.....	7
	1.3 Symbols and signal words.....	8
2	Safety instructions	11
3	Features	14
4	Installation	15
5	Starting up	19
6	Connections and controls	21
7	Operating	26
	7.1 Operating mode 'Manual'.....	26
	7.2 Operating mode 'Auto Run Mode'.....	29
	7.3 Operating mode 'Sound Mode'.....	29
	7.4 Operating mode 'DMX'.....	30
	7.5 Operating mode 'Slave'.....	38
	7.6 Operating mode 'Static Colour'.....	39
	7.7 Menu overview.....	40
	7.8 Control via optional remote control.....	42
	7.9 Checking the operating temperature.....	44

	7.10 Reset to factory defaults.....	44
8	Technical specifications.....	45
9	Plug and connection assignments.....	47
10	Troubleshooting.....	48
11	Cleaning.....	50
12	Protecting the environment.....	51



xBrick Quad 16×8W RGBW
LED Floodlight

1 General information

This user manual contains important information on the safe operation of the device. Read and follow all safety notes and all instructions. Save this manual for future reference. Make sure that it is available to all persons using this device. If you sell the device to another user, be sure that they also receive this manual.

Our products and user manuals are subject to a process of continuous development. We therefore reserve the right to make changes without notice. Please refer to the latest version of the user manual which is ready for download under www.thomann.de.

1.1 Further information

On our website (www.thomann.de) you will find lots of further information and details on the following points:

Download	This manual is also available as PDF file for you to download.
Keyword search	Use the search function in the electronic version to find the topics of interest for you quickly.
Online guides	Our online guides provide detailed information on technical basics and terms.
Personal consultation	For personal consultation please contact our technical hotline.
Service	If you have any problems with the device the customer service will gladly assist you.

1.2 Notational conventions

This manual uses the following notational conventions:

Letterings

The letterings for connectors and controls are marked by square brackets and italics.

Examples: *[VOLUME]* control, *[Mono]* button.

Displays



Texts and values displayed on the device are marked by quotation marks and italics.

Examples: '24*ch*', 'OFF'.

Instructions



The individual steps of an instruction are numbered consecutively. The result of a step is indented and highlighted by an arrow.

Example:

1.  Switch on the device.
2.  Press *[Auto]*.
 - ⇒ Automatic operation is started.
3.  Switch off the device.

1.3 Symbols and signal words

In this section you will find an overview of the meaning of symbols and signal words that are used in this manual.

Signal word	Meaning
DANGER!	This combination of symbol and signal word indicates an immediate dangerous situation that will result in death or serious injury if it is not avoided.
WARNING!	This combination of symbol and signal word indicates a possible dangerous situation that can result in death or serious injury if it is not avoided.
NOTICE!	This combination of symbol and signal word indicates a possible dangerous situation that can result in material and environmental damage if it is not avoided.
Warning signs	Type of danger
	Warning – high-voltage.
	Warning – dangerous optical radiation.
	Warning – suspended load.

Warning signs	Type of danger
	Warning – danger zone.

2 Safety instructions

Intended use

This device is intended for use as an electronic lighting effect by means of LED technology. The device is designed for professional use only and is not suitable for use in households. Use the device only as described in this user manual. Any other use or use under other operating conditions is considered to be improper and may result in personal injury or property damage. No liability will be assumed for damages resulting from improper use.

This device may be used only by persons with sufficient physical, sensorial, and intellectual abilities and having corresponding knowledge and experience. Other persons may use this device only if they are supervised or instructed by a person who is responsible for their safety.



Extend the operating life of the device by regular breaks and by avoiding frequent switching on and off. The device is not suitable for continuous operation.

Safety



DANGER!

Danger for children

Ensure that plastic bags, packaging, etc. are disposed of properly and are not within reach of babies and young children. Choking hazard! Ensure that children do not detach any small parts (e.g. knobs or the like) from the unit. They could swallow the pieces and choke! Never let children unattended use electrical devices.



DANGER!

Electric shock caused by high voltages inside

Within the device there are areas where high voltages may be present. Never remove any covers. There are no user-serviceable parts inside. Do not use the device if covers, protectors or optical components are missing or damaged.



DANGER!

Electric shock caused by short-circuit

Always use proper ready-made insulated mains cabling (power cord) with a protective contact plug. Do not modify the mains cable or the plug. Failure to do so could result in electric shock/death or fire. If in doubt, seek advice from a registered electrician.



WARNING!

Eye damage caused by high light intensity

Never look directly into the light source.



WARNING!

Risk of epileptic shock

Strobe lighting can trigger seizures in photosensitive epilepsy. Sensitive persons should avoid looking at strobe lights.



NOTICE!

Risk of fire

Do not block areas of ventilation. Do not install the device near any direct heat source. Keep the device away from naked flames.

**NOTICE!****Operating conditions**

This device has been designed for indoor use only. To prevent damage, never expose the device to any liquid or moisture. Avoid direct sunlight, heavy dirt, and strong vibrations. Only operate the device within the ambient conditions specified in the chapter 'Technical specifications' of this user manual. Avoid heavy temperature fluctuations and do not switch the device on immediately after it was exposed to temperature fluctuations (for example after transport at low outside temperatures). Dust and dirt inside can damage the unit. When operated in harmful ambient conditions (dust, smoke, nicotine, fog, etc.), the unit should be maintained by qualified service personnel at regular intervals to prevent overheating and other malfunction.

**NOTICE!****Power supply**

Before connecting the device, ensure that the input voltage (AC outlet) matches the voltage rating of the device and that the AC outlet is protected by a residual current circuit breaker. Failure to do so could result in damage to the device and possibly injure the user. Unplug the device before electrical storms occur and when it is unused for long periods of time to reduce the risk of electric shock or fire.

**NOTICE!****Possible damage due to installation of a wrong fuse**

The use of different types of fuses can cause serious damage to the unit. Fire hazard! Only fuses of the same type may be used.

3 Features

The LED floodlight is particularly suitable for professional lighting tasks, for example at events, on rock stages and in theatres and musicals. The device is characterised by excellent colour mixing properties and very high light output.

Special features of the device:

- 16 quad-colour LEDs (red, green, blue, white), 8 W each
- Control via DMX (five different modes), via buttons and display on the device and IR remote control (item no. 354223, optionally available)
- 23 preprogrammed automatic shows
- Sound control
- Master / slave mode
- Robust metal housing

For technological reasons, the light output of LEDs decreases over their lifetime. This effect increases with higher operating temperature. You can extend the service life of the illuminants by providing adequate ventilation and operating the LEDs with the lowest possible brightness.

4 Installation

Unpack and check carefully there is no transportation damage before using the unit. Keep the equipment packaging. To fully protect the product against vibration, dust and moisture during transportation or storage use the original packaging or your own packaging material suitable for transport or storage, respectively.



WARNING!

Risk of injury caused by falling objects

Make sure that the installation complies with the standards and rules that apply in your country. Always secure the device with a secondary safety attachment, such as a safety cable or a safety chain.



NOTICE!

Risk of overheating

The distance between light output and the illuminated surface must be more than 1.5 m (19.7in).

Provide sufficient ventilation.

The ambient temperature must always be below 40 °C (104 °F).



NOTICE!

Use of stands

When mounting the device onto a stand, ensure that the stand is in a safe and stable position and that the weight of the device does not exceed the maximum permissible load capacity of the stand.



NOTICE!

Possible data transmission errors

For error-free operation make use of dedicated DMX cables and do not use ordinary microphone cables.

Never connect the DMX input or output to audio devices such as mixers or amplifiers.



Please note that this device must not be connected to a dimmer.

Mounting options

You can install the unit in hanging or standing position. When in use, the device must always be attached to a solid surface or an approved truss. Use the openings provided on the two-piece bracket for attaching.

Always work from a stable platform whenever installing, moving or servicing the unit. In doing so, the area underneath the unit must be cordoned off.

Additionally secure the device by a safety cable against falling.

Inserting the battery into the remote control

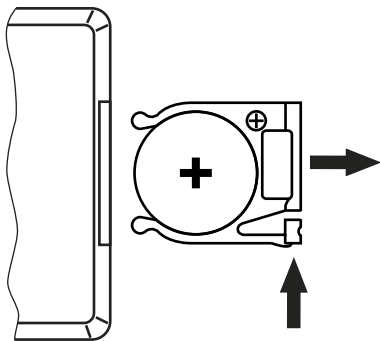

Press the lock of the battery holder to the centre of the housing and pull out the battery holder like a drawer. Insert the battery. The battery is correct if the positive pole points to the housing base of the remote control. Slide the battery holder back into the remote until it clicks into place.

When shipping, the battery is already installed in the remote and protected against discharge by a transparent plastic foil. Remove the plastic foil prior to first use.



NOTICE!

Risk of fire due to incorrect polarity

Incorrectly inserted batteries may destroy the device or the batteries.

Ensure that proper polarity is observed when inserting batteries.



NOTICE!

Possible damage by leaking batteries

Leaking batteries can cause permanent damage to the device.

Take batteries out of the device if it is not going to be used for a longer period.

5 Starting up

Create all connections while the device is off. Use the shortest possible high-quality cables for all connections. Take care when running the cables to prevent tripping hazards.

Connections in DMX mode

Connect the DMX input of the device to the DMX output of a DMX controller or another DMX device. Connect the output of the first DMX device to the input of the second one, and so on to form a daisy chain. Always ensure that the output of the last DMX device in the daisy chain is terminated with a resistor ($110\ \Omega$, $\frac{1}{4}\text{ W}$).

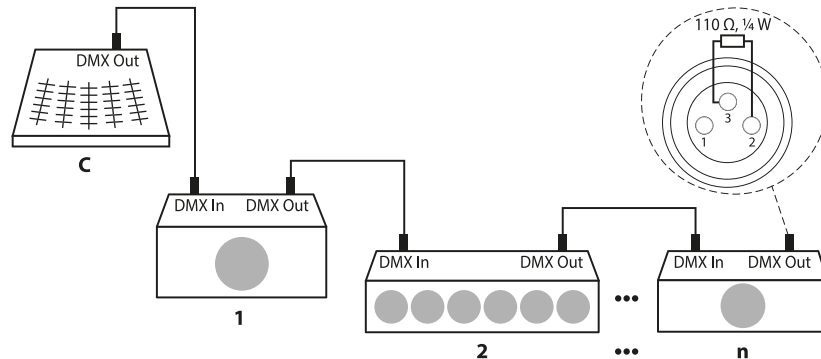

Connections in master/slave mode

When you configure a group of devices in master/slave mode, the first unit will control the other units for an automatic, sound-activated, synchronized show. This function is ideal when you want to start a show immediately. Connect the DMX output of the master device to the DMX input of the first slave device. Then connect the DMX output of the first slave device to the DMX input of the second slave device and so on.

6 Connections and controls

Rear panel

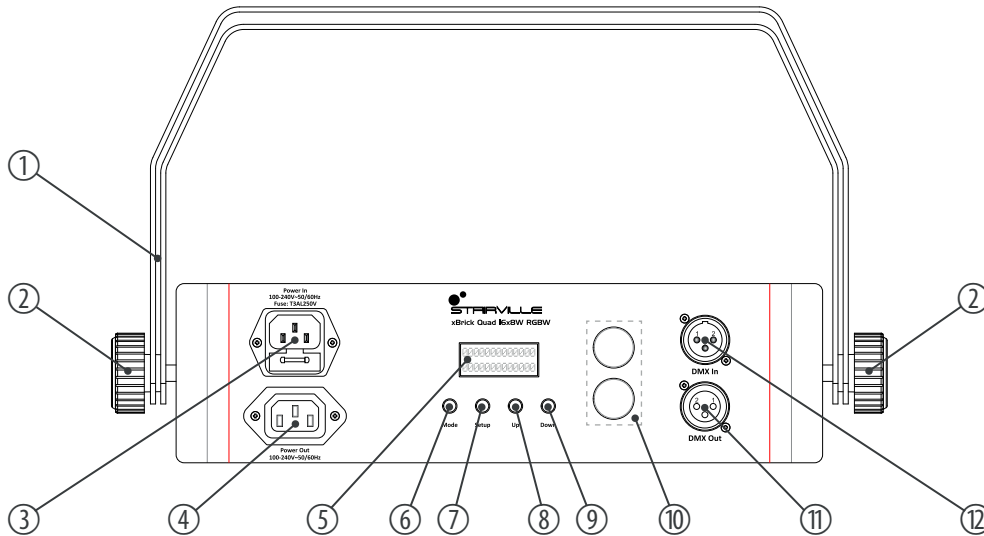

1	Bracket for floor placement or hanging
2	Locking screws for the brackets.
3	<i>[Power In]</i> IEC chassis plug for power supply with fuse holder
4	<i>[Power Out]</i> IEC chassis socket for the power supply of further devices
5	Display
6	<i>[Mode]</i> activates the main menu, saves changes
7	<i>[Setup]</i> selects an option of the respective operating mode
8	<i>[Up]</i> increases the displayed value by one
9	<i>[Down]</i> decreases the displayed value by one
10	Openings for fastening a safety rope
11	<i>[DMX Out]</i> DMX output
12	<i>[DMX In]</i> DMX input

Front panel

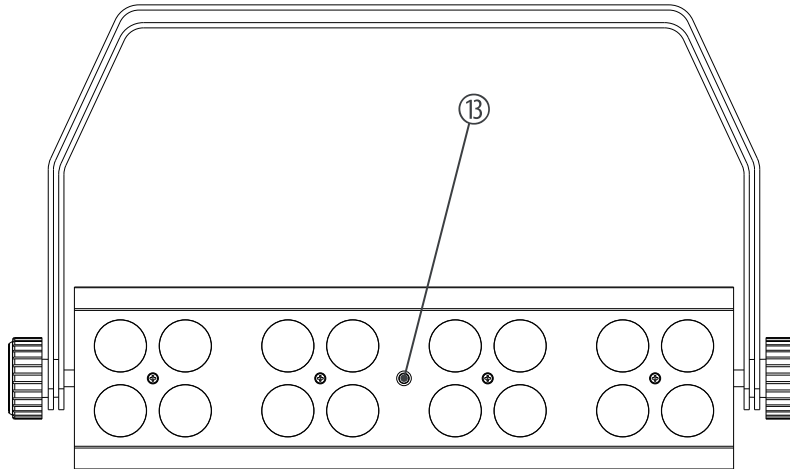

13 Infrared sensor for optionally available remote control

Infrared remote control (item no. 354223, optionally available)



Since the universal remote control can be used for several device types, some buttons may not be assigned and therefore have no function.

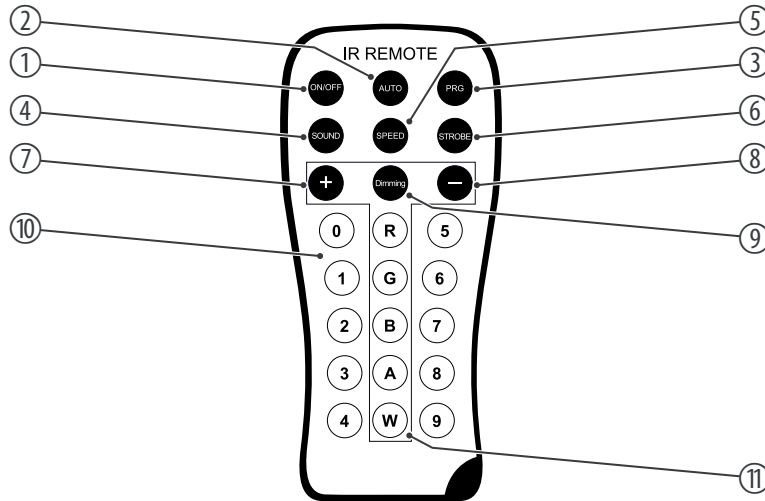

1	<i>[ON/OFF]</i> turns the device on and off.
2	<i>[AUTO]</i> activates the 'Automatic' mode.
3	<i>[PRG]</i> activates the operating mode 'Preprogrammed automatic show'. Select the desired programme with <i>[+]</i> and <i>[-]</i> .
4	<i>[SOUND]</i> activates the 'Sound-control' mode. Set the sensitivity of the built-in microphone with <i>[+]</i> and <i>[-]</i> .
5	<i>[SPEED]</i> activates the setting mode for the programme speed. Adjust the speed using <i>[+]</i> and <i>[-]</i> .
6	<i>[STROBE]</i> activates the setting mode for the Strobe speed. Adjust the speed using <i>[+]</i> and <i>[-]</i> .
7	<i>[+]</i> increases the set value.
8	<i>[-]</i> decreases the set value.
9	<i>[Dimming]</i> activates the dimming function for fixed colours. Set the value for each fixed colour using <i>[+]</i> and <i>[-]</i> .
10	<i>[0 ... 9]</i> numeric buttons for direct selection of a fixed colour.
11	<i>[R], [G], [B], [A], [W]</i> buttons to select the colour shade in dimmer mode.

7 Operating

Connect the device to the power supply to start operation. After a few seconds, the display indicates that a reset is in progress. The device is then ready for use.

Press *[Mode]* to activate the main menu and select an operating mode. Use *[Setup]* to select further options. Use *[Up]* and *[Down]* to change the respectively displayed value. The unit instantly applies the displayed value, you don't need to push a button for confirmation.

If you don't press any button for about 20 seconds, the current setting will be automatically applied and the display turns off. The set values are retained as long as the device is connected to the mains power supply.

7.1 Operating mode 'Manual'

This operating mode can only be activated when the unit is operating in stand alone mode or as master in a master / slave combination. This setting is only relevant if the device is not controlled via DMX.

1. ➤ Press *[Mode]*, use *[Up]* and *[Down]* to select the menu option 'Program Mode' and confirm with *[Setup]*.
2. ➤ Use *[Up]* and *[Down]* to select the desired programme (01 ... 23) and confirm with *[Setup]*.

Settings for programme 01

If you have selected programme 01, you can use *[Up]* and *[Down]* to select one of 15 static colour settings for all LEDs, see the following table.

Colour	Display
Cyan	'00'
Purple	'01'
Pink	'02'
Orange	'03'
Cold white	'04'
Light red	'05'
Light green	'06'
Bright blue	'07'
Yellow	'08'
Warm white	'09'
Red	'10'
Green	'11'
Blue	'12'

Colour	Display
Amber	'13'
All	'14'
Blackout	'15'

Settings for programmes 02 ... 23

When you have selected one of programmes 02 ... 23 you can adjust the following settings:

1. ➤ After selecting the programme, press *[Setup]* again and set the programme running speed with *[Up]* and *[Down]* in a range from '001' ... '100' (slow ... fast).
2. ➤ Press *[Setup]* again and set the flashing speed for the strobe effect with *[Up]* and *[Down]* in a range from '001' ... '100' (slow ... fast).

7.2 Operating mode 'Auto Run Mode'

A preprogrammed automatic show can only be activated when the unit is operating in stand-alone mode or as master in a master / slave combination. This setting is only relevant if the device is not controlled via DMX.

1. ➤ Press *[Mode]*, use *[Up]* and *[Down]* to select the menu option 'Auto Run Mode' and confirm with *[Setup]*.
2. ➤ Use *[Up]* and *[Down]* to set the programme running speed in a range from '001' ... '100' (slow ... fast) and confirm with *[Setup]*.
3. ➤ Use *[Up]* and *[Down]* to set the flashing speed for the strobe effect in a range from '001' ... '100' (slow ... fast) and confirm with *[Setup]*.
4. ➤ Use *[Up]* and *[Down]* to set the number of runs in a range from '001' ... '100' (slow ... fast) and confirm with *[Setup]* to exit the menu.

7.3 Operating mode 'Sound Mode'

This setting is only relevant if the device is working as Slave in a Master / Slave configuration and is not controlled via DMX. In this operating mode, the device responds to acoustic pulses which are recorded by the integrated microphone.

1. ➤ Press *[Mode]*, use *[Up]* and *[Down]* to select the menu option 'Sound Mode' and confirm with *[Setup]*.
2. ➤ Use *[Up]* and *[Down]* to set the sensitivity of the built-in microphone in a range from '00' ... '31' (minimum ... maximum brightness) and confirm with *[Setup]*.
3. ➤ Use *[Up]* and *[Down]* to select one of the options 'Scene 1' for slow or 'Scene 2' for fast transitions between the programmed shows and confirm with *[Setup]* to exit the menu.

7.4 Operating mode 'DMX'

This setting is only relevant if the device is controlled via a DMX controller.

1. ➤ Press *[Mode]*, use *[Up]* and *[Down]* to select the menu option 'DMX 512 Mode' and confirm with *[Setup]*.
2. ➤ Use *[Up]* and *[Down]* to assign a DMX address in a range from '001' ... '512' to the device and confirm with *[Setup]*.

3. ▶ Press *[Up]* and *[Down]* to select the desired DMX mode:

Mode	Highest possible DMX address
4-channel	509
6-channel	507
8-channel	505
16-channel	497
18-channel	495

4. ▶ Confirm with *[Setup]*.

7.4.1 Functions in 4-channel DMX mode

Channel	Value	Function
1	0...255	Intensity red (0 % to 100 %)
2	0...255	Intensity green (0 % to 100 %)
3	0...255	Intensity blue (0 % to 100 %)
4	0...255	Intensity white (0 % to 100 %)

7.4.2 Functions in 6-channel DMX mode

Channel	Value	Function
1	0...255	Intensity red (0 % to 100 %)
2	0...255	Intensity green (0 % to 100 %)
3	0...255	Intensity blue (0 % to 100 %)
4	0...255	Intensity white (0 % to 100 %)
5	0...255	Dimmer (0 % to 100 %)
6	0...255	Stroboscope effect (0 % to 100 %)

7.4.3 Functions in 8-channel DMX mode

Channel	Value	Function
1	0 ... 255	Intensity red (0 % to 100 %), if channel 7 = 0 ... 4
2	0 ... 255	Intensity green (0 % to 100 %), if channel 7 = 0 ... 4
3	0 ... 255	Intensity blue (0 % to 100 %), if channel 7 = 0 ... 4
4	0 ... 255	Intensity white (0 % to 100 %), if channel 7 = 0 ... 4

Channel	Value	Function
5	0 ... 255	Dimmer (0 % bis 100 %), if channel 7 = 5 ... 233
6	0 ... 255	Stroboscope effect (0 % to 100 %), if channel 7 = 5 ... 233
7	0 ... 4	No function
	5 ... 9	Intensity cyan (0 % to 100 %)
	10 ... 14	Intensity purple (0 % to 100 %)
	15 ... 19	Intensity pink (0 % to 100 %)
	20 ... 24	Intensity orange (0 % to 100 %)
	25 ... 29	Intensity cold white (0 % to 100 %)
	30 ... 34	Intensity bright red (0 % to 100 %)
	35 ... 39	Intensity bright green (0 % to 100 %)
	40 ... 44	Intensity bright blue (0 % to 100 %)
	45 ... 49	Intensity yellow (0 % to 100 %)
	50 ... 54	Intensity warm white (0 % to 100 %)
	55 ... 59	Intensity red (0 % to 100 %)
	60 ... 64	Intensity green (0 % to 100 %)
	65 ... 69	Intensity blue (0 % to 100 %)

Channel	Value	Function
	70 ... 74	Intensity amber (0 % to 100 %)
	75 ... 79	All
	80 ... 86	Programme 02
	87 ... 93	Programme 03
	94 ... 100	Programme 04
	101 ... 107	Programme 05
	108 ... 114	Programme 06
	115 ... 121	Programme 07
	122 ... 128	Programme 08
	129 ... 135	Programme 09
	136 ... 142	Programme 10
	143 ... 149	Programme 11
	150 ... 156	Programme 12
	157 ... 163	Programme 13
	164 ... 170	Programme 14
	171 ... 177	Programme 15

Channel	Value	Function
	178 ... 184	Programme 16
	185 ... 191	Programme 17
	192 ... 198	Programme 18
	199 ... 205	Programme 19
	206 ... 212	Programme 20
	213 ... 219	Programme 21
	220 ... 226	Programme 22
	227 ... 233	Programme 23
	234 ... 240	Sound-controlled operation, slow transition programmes 02 to 23
	241 ... 255	Sound-controlled operation, fast transition programmes 02 to 23
8		No function, if channel 7 = 0 ... 79
	0 ... 255	Programme speed, if channel 7 = 80 ... 233
	0 ... 255	Microphone sensitivity, if channel 7 = 234 ... 255

7.4.4 Functions in 16-channel DMX mode

Channel	Value	Function
1	0 ... 255	Intensity red (0 % to 100 %), segment 1
2	0 ... 255	Intensity green (0 % to 100 %), segment 1
3	0 ... 255	Intensity blue (0 % to 100 %), segment 1
4	0 ... 255	Intensity white (0 % to 100 %), segment 1
5	0 ... 255	Intensity red (0 % to 100 %), segment 2
6	0 ... 255	Intensity green (0 % to 100 %), segment 2
7	0 ... 255	Intensity blue (0 % to 100 %), segment 2
8	0 ... 255	Intensity white (0 % to 100 %), segment 2
9	0 ... 255	Intensity red (0 % to 100 %), segment 3
10	0 ... 255	Intensity green (0 % to 100 %), segment 3
11	0 ... 255	Intensity blue (0 % to 100 %), segment 3
12	0 ... 255	Intensity white (0 % to 100 %), segment 3
13	0 ... 255	Intensity red (0 % to 100 %), segment 4
14	0 ... 255	Intensity green (0 % to 100 %), segment 4

Channel	Value	Function
15	0 ... 255	Intensity blue (0 % to 100 %), segment 4
16	0 ... 255	Intensity white (0 % to 100 %), segment 4

7.4.5 Functions in 18-channel DMX mode

Channel	Value	Function
1	0 ... 255	Intensity red (0 % to 100 %), segment 1
2	0 ... 255	Intensity green (0 % to 100 %), segment 1
3	0 ... 255	Intensity blue (0 % to 100 %), segment 1
4	0 ... 255	Intensity white (0 % to 100 %), segment 1
5	0 ... 255	Intensity red (0 % to 100 %), segment 2
6	0 ... 255	Intensity green (0 % to 100 %), segment 2
7	0 ... 255	Intensity blue (0 % to 100 %), segment 2
8	0 ... 255	Intensity white (0 % to 100 %), segment 2
9	0 ... 255	Intensity red (0 % to 100 %), segment 3
10	0 ... 255	Intensity green (0 % to 100 %), segment 3

Channel	Value	Function
11	0 ... 255	Intensity blue (0 % to 100 %), segment 3
12	0 ... 255	Intensity white (0 % to 100 %), segment 3
13	0 ... 255	Intensity red (0 % to 100 %), segment 4
14	0 ... 255	Intensity green (0 % to 100 %), segment 4
15	0 ... 255	Intensity blue (0 % to 100 %), segment 4
16	0 ... 255	Intensity white (0 % to 100 %), segment 4
17	0 ... 255	Dimmer (0 % to 100 %)
18	0 ... 255	Stroboscope effect (0 % to 100 %)

7.5 Operating mode 'Slave'

This setting is only relevant if the device is working as Slave in a Master / Slave configuration and is not controlled via DMX. For enabling the operating mode, press *[Mode]* repeatedly until the display shows 'Slave'.

7.6 Operating mode 'Static Colour'

This setting is only relevant if the device is working in Stand Alone mode and is not controlled via DMX. In this mode you have the option to select a solid colour for continuous operation and to set the flash frequency for all LEDs.

1. ➤ Press *[Mode]*, use *[Up]* and *[Down]* to select the menu option 'Static Colour Mode' and confirm with *[Setup]*.
2. ➤ Use *[Up]* and *[Down]* to specify the intensity of the colour red in a range from '000' ... '255' (bright ... dark) and confirm with *[Setup]*.
3. ➤ Use *[Up]* and *[Down]* to specify the intensity of the colour green in a range from '000' ... '255' (bright ... dark) and confirm with *[Setup]*.
4. ➤ Use *[Up]* and *[Down]* to specify the intensity of the colour blue in a range from '000' ... '255' (bright ... dark) and confirm with *[Setup]*.
5. ➤ Use *[Up]* and *[Down]* to specify the intensity of the colour white in a range from '000' ... '255' (bright ... dark) and confirm with *[Setup]*.
6. ➤ Use *[Up]* and *[Down]* to specify the flashing speed of the LEDs in a range from '000' ... '255' (slow ... fast) and confirm with *[Setup]* to exit the menu.

7.7 Menu overview

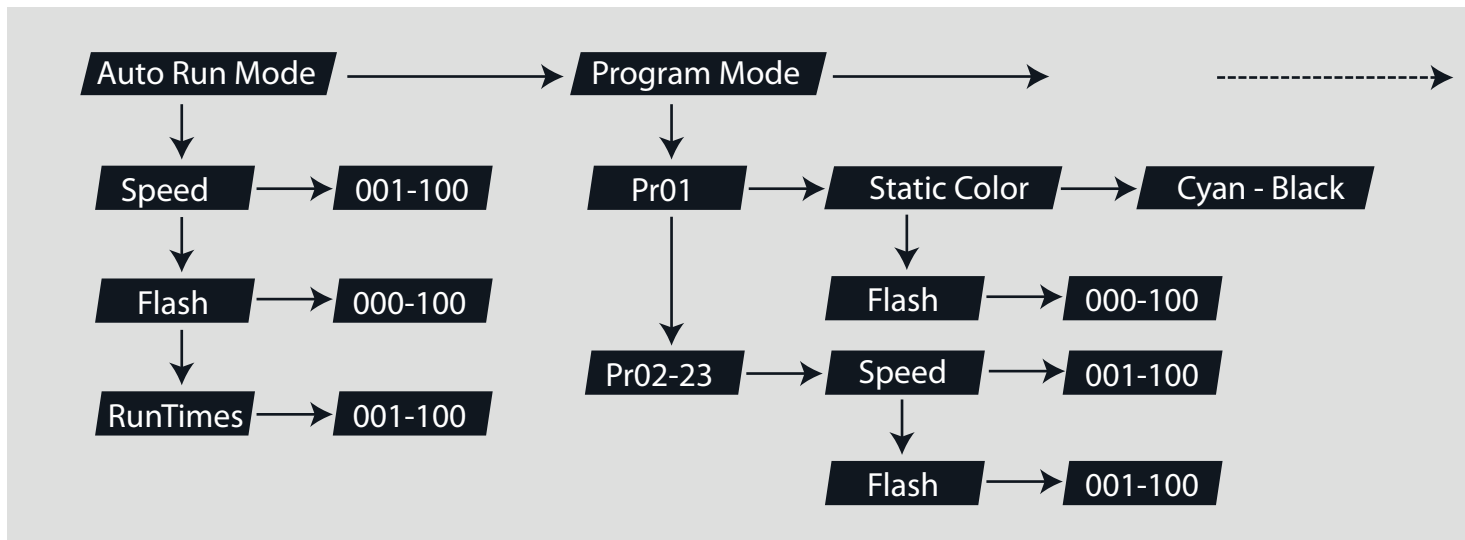

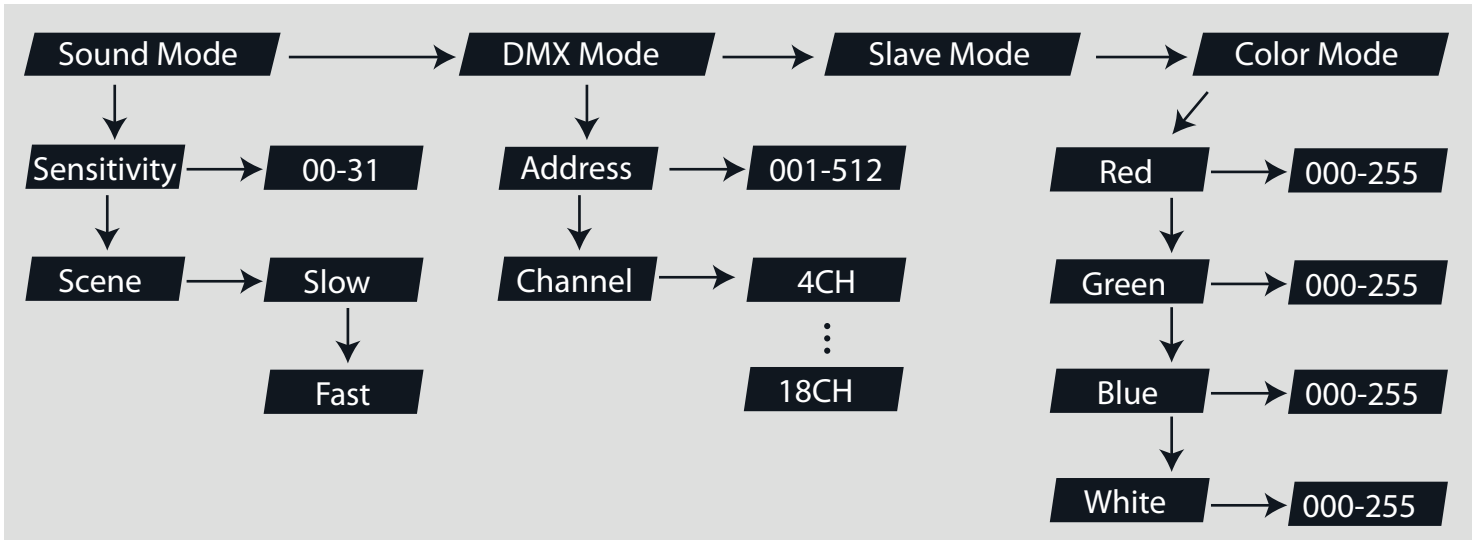

7.8 Control via optional remote control

If the device neither is working as Slave in a Master / Slave configuration nor is not controlled via DMX you can control it using the remote control.

Switching on / off

Use *[ON/OFF]* to switch the device on and off.

Operating mode 'Automatic'

Press *[AUTO]*. The playback of 'Pr02' to 'Pr23' starts automatically.

Operating mode 'Preprogrammed automatic show'

Press *[PRG]*. Use *[+]* and *[-]* to select a value between 'Pr.01' and 'Pr.23'.

In the 'Preprogrammed automatic show' mode, you can activate the strobe effect. Press *[STROBE]* and use *[+]* and *[-]* to select a value between '001' (slow) and '100' (fast). Press again *[STROBE]* to disable the Strobe effect.

For the programmes 'Pr.02' and 'Pr.23', it is possible to adjust the process speed. Press *[SPEED]* and use *[+]* and *[-]* to select a value between '001' (slow) and '100' (fast).

Sound control

Press *[SOUND]*. This activates a sound controlled automatic show.

Use *[+]* and *[-]* to adjust the sensitivity of the sound control in a range from 'SV.00' to 'SV.31' and confirm with *[Setup]*.

Use *[Up]* and *[Down]* to select one of the options 'Scene 1' for fast or 'Scene 2' for slow transitions between the programmed shows.

Dimming

Press *[Dimming]* to adjust the brightness level of the primary colours. Press *[R]* (red), *[G]* (green), or *[B]* (blue) and use *[+]* and *[-]* to select a value between 0 and 255.

Colour selection

Use the coloured buttons to select a colour tone in any mode. The following assignment applies:

Button	Colour	Button	Colour	Button	Colour
0	Cyan	5	Light red	R	Red
1	Purple	6	Light green	G	Green
2	Magenta	7	Bright blue	B	Blue
3	Orange	8	Yellow	A	Amber
4	Cold white	9	Warm white	W	White

Resetting to factory defaults

To reset the device, press *[OFF]* and subsequently *[9]*, *[8]*, and *[7]*.

7.9 Checking the operating temperature

To check the operating temperature, first turn the device off. Keep the button *[Mode]* pressed and turn the device on again. If the permissible operating temperature is exceeded, the display shows *Tr:Er'*.

In this case, switch the device off and let it cool down for some time.

7.10 Reset to factory defaults

To reset all values to their factory default settings press simultaneously *[Mode]* and *[Setup]*.

8 Technical specifications

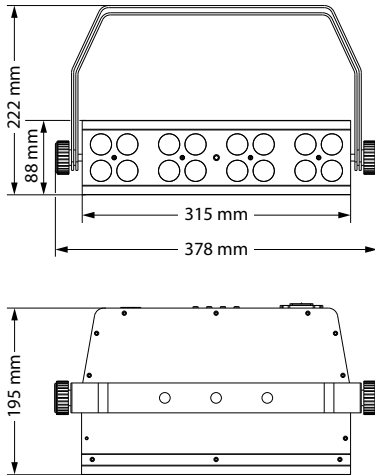

Light source		16 × 4in1 RGBW, 8 W
Optical properties	Beam angle	25 °
Control		DMX
		IR remote control (optional)
Number of DMX channels		4, 6, 8, 16, 18
Input connections	Power supply	IEC chassis plug C14
	DMX control	XLR chassis plug, 3-pin
Output connections	Power supply	IEC chassis socket C13
	DMX control	XLR chassis socket, 3-pin
Power consumption		125 W
Supply voltage		100 - 240 V ~ 50/60 Hz
Fuse		5 mm × 20 mm, 3 A, 250 V, slow-blow
Battery remote control		Lithium-ion button cell CR2025, 3 V
Degree of protection		IP20
Mounting options		Hanging, standing

Dimensions (W × H × D)		315 mm × 88 mm × 195 mm (without bracket) 378 mm × 222 mm × 195 mm (incl. bracket)
Weight		4.3 kg
Ambient conditions	Temperature range	0 °C...40 °C
	Relative humidity	20 %...80 % (non-condensing)

Further information

Suitable for outdoor use	no
Design	Flat PAR
Colour mixture	RGBW
LED type	x-in-1
fanless	no
Housing colour	black
Separately controllable LEDs	yes

9 Plug and connection assignments

Introduction

This chapter will help you select the right cables and plugs to connect your valuable equipment so that a perfect light experience is guaranteed.

Please take our tips, because especially in 'Sound & Light' caution is indicated: Even if a plug fits into a socket, the result of an incorrect connection may be a destroyed DMX controller, a short circuit or 'just' a not working light show!

DMX connections

The unit offers a 3-pin XLR socket for DMX output and a 3-pin XLR plug for DMX input. Please refer to the drawing and table below for the pin assignment of a suitable XLR plug.



Pin	Configuration
1	Ground, shielding
2	Signal inverted (DMX-, 'cold signal')
3	Signal (DMX+, 'hot signal')

10 Troubleshooting



NOTICE!

Possible data transmission errors

For error-free operation make use of dedicated DMX cables and do not use ordinary microphone cables.

Never connect the DMX input or output to audio devices such as mixers or amplifiers.

In the following we list a few common problems that may occur during operation. We give you some suggestions for easy troubleshooting:

The unit does not work, no light, the fan does not run



Check the mains connection and main fuse.

No response to the DMX controller

1. ▶ Check the DMX connectors and cables for proper connection
2. ▶ Check the address settings and the DMX polarity.
3. ▶ Try using another DMX controller.
4. ▶ Check whether the DMX cables run near or parallel to high-voltage cables that may cause damage or interference to a DMX interface circuit.

If the procedures recommended above do not succeed, please contact our Service Center. You can find the contact information at www.thomann.de.

11 Cleaning

Optical lenses

Clean the optical lenses, that are accessible from the outside, regularly in order to optimize the light output. The frequency of cleaning depends on the operating environment: wet, smoky or particularly dirty surroundings can cause more accumulation of dirt on the optics of the device.

- Clean with a soft cloth using our lamp and lens cleaner (item no. 280122).
- Always dry the parts carefully.

Fan grids

The fan grids of the device must be cleaned of any contamination, such as dust, etc. on a regular basis. Before cleaning, switch off the device and disconnect mains-operated devices from the mains. Only use pH-neutral, solvent-free and non-abrasive cleaning agents. Clean the unit with a slightly damp lint-free cloth.

12 Protecting the environment

Disposal of the packaging material



For the packaging, environmentally friendly materials have been chosen that can be supplied to normal recycling.

Ensure that plastic bags, packaging, etc. are properly disposed of.

Do not just dispose of these materials with your normal household waste, but make sure that they are collected for recycling. Please follow the notes and markings on the packaging.

Disposal of batteries



Batteries must not be thrown away or incinerated; they must be disposed of in accordance with local regulations for the disposal of hazardous waste. Use the existing collection points for this.

Only dispose of lithium batteries when they are discharged. Remove replaceable lithium batteries from the device before disposal. Protect used lithium batteries against short circuits, for example by covering the poles with adhesive tape. Permanently built-in lithium batteries must be disposed of together with the device. Please inquire about an appropriate collection point.

Disposal of your old device



This product is subject to the European Waste Electrical and Electronic Equipment Directive (WEEE) in its currently valid version. Do not dispose with your normal household waste.

Dispose of this device through an approved waste disposal firm or through your local waste facility. When discarding the device, comply with the rules and regulations that apply in your country. If in doubt, consult your local waste disposal facility.

