



Outdoor Stage PAR
12 × 4W Quad IR RGBW,
12 × 3W Quad IR UV
LED PAR

Musikhaus Thomann
Thomann GmbH
Hans-Thomann-Straße 1
96138 Burgebrach
Germany
Telephone: +49 (0) 9546 9223-0
E-mail: info@thomann.de
Internet: www.thomann.de

10.03.2017, ID: 387911, 387902

Table of contents

1	General notes	5
1.1	Further information.....	6
1.2	Notational conventions.....	7
1.3	Symbols and signal words.....	8
2	Safety instructions	11
3	Features	16
4	Installation	17
5	Starting up	21
6	Connections and controls	24
7	Operating	30
7.1	Operating mode 'Auto Run Mode'.....	31
7.2	Operating mode 'Manual' (only 12×4W Quad IR RGBW).....	32
7.3	Operating mode 'Static Colour' (12×4W Quad IR RGBW).....	35
7.4	Operating mode 'Static Colour' (12×3W Quad IR UV).....	36
7.5	Operating mode 'DMX' (12×4W Quad IR RGBW).....	36

7.6	Operating mode 'DMX' (12×3W Quad IR UV).....	42
7.7	Operating mode 'Slave'.....	45
7.8	Remote control (optional, 12×4W Quad IR RGBW).....	45
7.9	Remote control (optional, 12×3W Quad IR UV).....	48
8	Technical specifications.....	50
9	Plug and connection assignments.....	52
10	Troubleshooting.....	53
11	Cleaning.....	55
12	Protecting the environment.....	56

1 General notes

This manual contains important instructions for the safe operation of the unit. Read and follow the safety instructions and all other instructions. Keep the manual for future reference. Make sure that it is available to all those using the device. If you sell the unit please make sure that the buyer also receives this manual.

Our products are subject to a process of continuous development. Thus, they are subject to change.

1.1 Further information

On our website (www.thomann.de) you will find lots of further information and details on the following points:

Download	This manual is also available as PDF file for you to download.
Keyword search	Use the search function in the electronic version to find the topics of interest for you quickly.
Online guides	Our online guides provide detailed information on technical basics and terms.
Personal consultation	For personal consultation please contact our technical hotline.
Service	If you have any problems with the device the customer service will gladly assist you.

1.2 Notational conventions

This manual uses the following notational conventions:

Letterings

The letterings for connectors and controls are marked by square brackets and italics.

Examples: *[VOLUME]* control, *[Mono]* button.

Displays

Texts and values displayed on the device are marked by quotation marks and italics.

Examples: *'24ch'*, *'OFF'*.

Instructions



The individual steps of an instruction are numbered consecutively. The result of a step is indented and highlighted by an arrow.



Example:

- 1.** ▶ Switch on the device.
- 2.** ▶ Press *[Auto]*.
⇒ Automatic operation is started.
- 3.** ▶ Switch off the device.

1.3 Symbols and signal words

In this section you will find an overview of the meaning of symbols and signal words that are used in this manual.

Signal word	Meaning
DANGER!	This combination of symbol and signal word indicates an immediate dangerous situation that will result in death or serious injury if it is not avoided.
WARNING!	This combination of symbol and signal word indicates a possible dangerous situation that can result in death or serious injury if it is not avoided.
NOTICE!	This combination of symbol and signal word indicates a possible dangerous situation that can result in material and environmental damage if it is not avoided.
Warning signs	Type of danger
	Warning – high-voltage.
	Warning – hot surface.

Warning signs	Type of danger
 A yellow triangular warning sign with a black border, depicting a crane hook lifting a rectangular load.	Warning – suspended load.
 A yellow triangular warning sign with a black border, featuring a large black exclamation mark.	Warning – danger zone.

2 Safety instructions

Intended use

This device is intended to be used as an electronic illumination effect using LED technics. The device is designed for professional use and is not suitable for use in households. Use the device only as described in this user manual. Any other use or use under other operating conditions is considered to be improper and may result in personal injury or property damage. No liability will be assumed for damages resulting from improper use.

This device may be used only by persons with sufficient physical, sensorial, and intellectual abilities and having corresponding knowledge and experience. Other persons may use this device only if they are supervised or instructed by a person who is responsible for their safety.

Safety



DANGER!

Danger for children

Ensure that plastic bags, packaging, etc. are disposed of properly and are not within reach of babies and young children. Choking hazard!

Ensure that children do not detach any small parts (e.g. knobs or the like) from the unit. They could swallow the pieces and choke!

Never let children unattended use electrical devices.



DANGER!

Electric shock caused by short-circuit

Do not modify the mains cable or the plug. Failure to do so could result in electric shock/death or fire. If in doubt, seek advice from a registered electrician.



DANGER!

Electric shock caused by high voltages inside

Within the device there are areas where high voltages may be present. Never remove any covers.

There are no user-serviceable parts inside.



WARNING!

Eye damage caused by high light intensity

Never look directly into the light source.



WARNING!

Risk of epileptic shock

Strobe lighting can trigger seizures in photosensitive epilepsy. Sensitive persons should avoid looking at strobe lights.



WARNING!

Risk of burns

The surface of the device can become very hot during operation.

Do not touch the device with bare hands during operation, and after switching off wait for at least 15 minutes.



NOTICE!

Risk of fire

Do not cover the device nor any ventilation slots. Do not place the device near any direct heat source. Keep the device away from naked flames.



NOTICE!

Power supply

Before connecting the device, ensure that the input voltage (AC outlet) matches the voltage rating of the device and that the AC outlet is protected by a residual current circuit breaker. Failure to do so could result in damage to the device and possibly injure the user.

Unplug the device before electrical storms occur and when it is unused for long periods of time to reduce the risk of electric shock or fire.

3 Features

Due to its sturdy and weather-proof housing made of die-cast aluminium, the Outdoor Stage PAR is especially suitable for outdoor use. The very bright UV or quad-colour LEDs make it particularly suitable for professional lighting tasks.

- LED configuration
 - **Outdoor Stage PAR 12x4W Quad IR RGBW** with 12 Quad-Color LEDs
 - **Outdoor Stage PAR 12x3W Quad IR UV** with 12 UV LEDs
- Control via DMX (3 different modes), buttons and display on the unit or via IR remote control (optional, not included)
- preprogrammed automatic shows
- Master / Slave operation
- rugged die-cast aluminium housing
- IP65 (suitable for outdoor use)
- Connectors for power supply and DMX control via splashproof screw-mountable plugs and couplings
- sturdy double bracket for secure attachment to trusses or firm footing on the ground

4 Installation

Unpack and carefully check that there is no transportation damage before using the unit. Keep the equipment packaging. To fully protect the device against vibration, dust and moisture during transportation or storage use the original packaging or your own packaging material suitable for transport or storage, respectively.



WARNING!

Risk of injury caused by falling objects

Make sure that the installation complies with the standards and rules that apply in your country. Always secure the device with a secondary safety attachment, such as a safety cable or a safety chain.



NOTICE!

Risk of overheating

Always ensure sufficient ventilation.

The ambient temperature must not exceed the limits stated in the chapter Technical Specifications of the User Manual.



NOTICE!

Use of stands

When mounting the device onto a stand, ensure that the stand is in a safe and stable position and that the weight of the device does not exceed the maximum permissible load capacity of the stand.

**NOTICE!****Possible data transmission errors**

For error-free operation make use of dedicated DMX cables and do not use ordinary microphone cables.

Never connect the DMX input or output to audio devices such as mixers or amplifiers.

Mounting options

You can install the device standing or hanging upside down. When in use, the device must be mounted at a solid surface or clamped to an approved truss. Use the openings of the two-piece bracket provided for mounting.

Work from a stable platform whenever you install or move the device or when you perform any kind of maintenance. Block access under the work area.

The safety cable must be attached to the bracket.



Please note that this device must not be connected to a dimmer.

5 Starting up

Create all connections while the device is off. Use the shortest possible high-quality cables for all connections. Take care when running the cables to prevent tripping hazards.

Connections in DMX mode

Connect the DMX input of the device to the DMX output of a DMX controller or another DMX device. Connect the output of the first DMX device to the input of the second one, and so on to form a daisy chain. Always ensure that the output of the last DMX device in the daisy chain is terminated with a resistor ($110\ \Omega$, $\frac{1}{4}\text{ W}$).

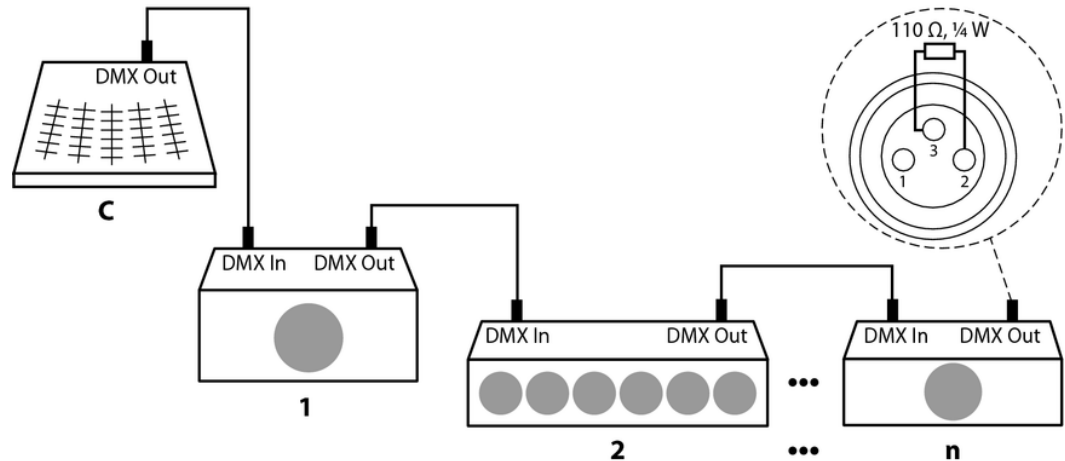

Connections in master/slave mode

When you configure a group of devices in master/slave mode, the first unit will control the other units for an automatic, sound-activated, synchronized show. This function is ideal when you want to start a show immediately. Connect the DMX output of the master device to the DMX input of the first slave device. Then connect the DMX output of the first slave device to the DMX input of the second slave device and so on.

6 Connections and controls

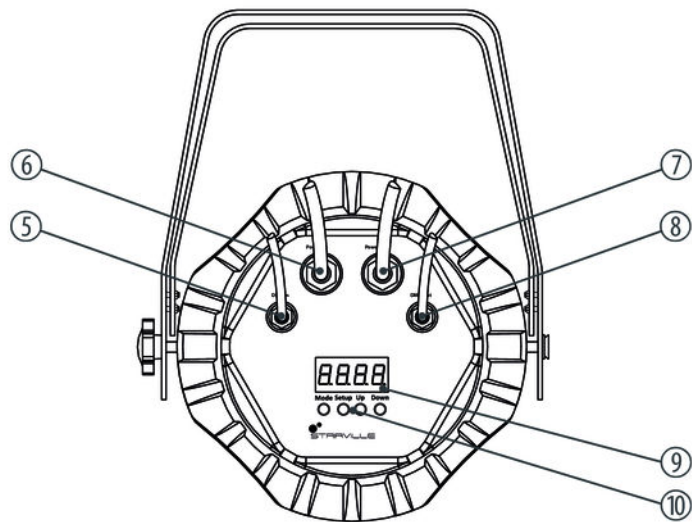
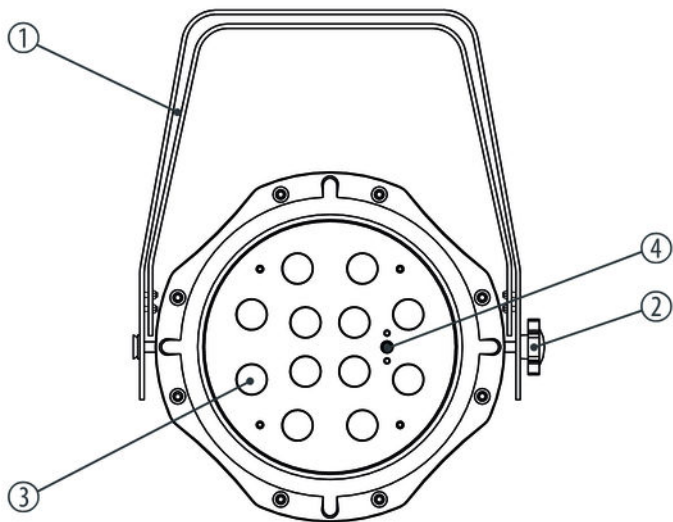

1	Two-piece bracket for hanging or installation and for securing the safety-rope.
2	Locking screws.
3	LEDs.
4	Infrared sensor for optionally available remote control.
5	<i>[DMX IN]</i> DMX input cable.
6	<i>[Power In]</i> Mains cable for the power supply of the device.
7	<i>[Power Out]</i> Power cord for the voltage supply of a connected device.
8	<i>[DMX OUT]</i> DMX output cable.

9 Display.

10 Control buttons

[Mode]: Activates the main menu and toggles between menu items.

[Setup]: Selects an option of the respective operating mode.

[Up]: Increases the displayed value by one.

[Down]: Decreases the displayed value by one.

Remote control (optional)

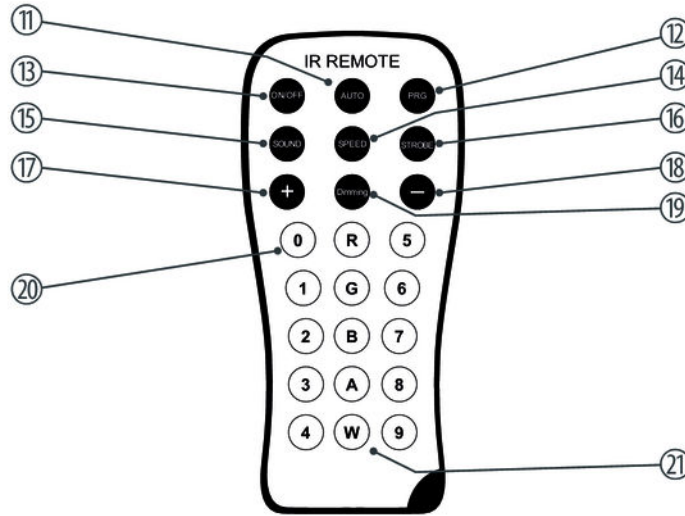

Outdoor Stage PAR 12 × 4W Quad IR RGBW, 12 × 3W Quad IR UV

11	<i>[AUTO]</i> Activates the 'Automatic' mode.
12	<i>[PRG]</i> Activates the operating mode 'Preprogrammed automatic show'. Select the desired programme with the buttons <i>[+]</i> and <i>[-]</i> .
13	<i>[ON/OFF]</i> Activates / deactivates the device.
14	<i>[SPEED]</i> Activates the setting mode for the programme speed. Adjust the speed using the buttons <i>[+]</i> and <i>[-]</i> .
15	<i>[SOUND]</i> No function.
16	<i>[STROBE]</i> Turns the strobe effect on / off.
17	<i>[+]</i> Increases the set value.

18	<i>[-]</i> Decreases the set value.
19	<i>[Dimming]</i> Enables the dimmer function.
20	<i>[0 ... 9]</i> Numeric buttons for direct selection of a fixed colour.
21	<i>[R], [G], [B], [A], [W]</i> Buttons to select a colour tone for the dimmer mode.

7 Operating

Connect the device to the power supply to start operation. After a few seconds, the display indicates that a reset is in progress. The device is then ready for use.

Press *[Mode]* to activate the main menu and select an operating mode. Use *[Setup]* to select further options. Use *[Up]* and *[Down]* to change the respectively indicated value. The unit instantly applies the displayed value, you don't need to push a button for confirmation.

If you don't press any button for about 20 seconds, the current setting will be automatically applied and the display turns off. The set values are retained as long as the device is connected to the mains power supply.

7.1 Operating mode 'Auto Run Mode'

In automatic mode, all programmed shows are played sequentially in an endless loop.

A preprogrammed automatic show can only be activated when the unit is operating in stand-alone mode or as master in a master / slave combination. This setting is only relevant if the device is not controlled via DMX.

1. ➤ Press *[Mode]*, use *[Up]* and *[Down]* to select the menu option 'Auto' and confirm with *[Setup]*.
2. ➤ Adjust the programme speed with *[Up]* and *[Down]* in a range from 'SP.01' ... 'SP.FL' (slow ... fast) and confirm with *[Setup]*.
3. ➤ Adjust the frequency of the strobe effect with *[Up]* and *[Down]* in a range from 'F5.00' ... 'F5.99' (slow ... fast) and confirm with *[Setup]*.

7.2 Operating mode 'Manual' (only 12×4W Quad IR RGBW)

This operating mode can only be activated when the unit is operating in stand alone mode or as master in a master / slave combination. This setting is only relevant if the device is not controlled via DMX.

1. ➤ Press *[Mode]*, use *[Up]* and *[Down]* to select the menu option 'Pro' and confirm with *[Setup]*.
2. ➤ Use *[Up]* and *[Down]* to select the desired programme (01 ... 07) and confirm with *[Setup]*.

Settings for program 01

When you have selected programme 01, you can use *[Setup]* to access the settings. Now use *[Up]* and *[Down]* to select one of 15 static colour settings for all LEDs, see the following chart.

Colour	Display
Cyan	'00'
Purple	'01'
Pink	'02'
Orange	'03'
Cold white	'04'
Bright red	'05'
Bright green	'06'
Bright blue	'07'
Yellow	'08'
Warm white	'09'

Colour	Display
Red	'10'
Green	'11'
Blue	'12'
Amber	'13'
All	'14'
Blackout	'15'

Settings for programmes 02 ... 07

When you have selected one of programmes 02 ... 07 you can adjust the following settings:

- After selecting the programme, press again *[Setup]* and adjust the programme speed with *[Up]* and *[Down]* in a range from 'SP.01' ... 'SP.FL' (slow ... fast) and confirm with *[Setup]*.
- Press again *[Setup]* and adjust the frequency of the strobe effect with *[Up]* and *[Down]* in a range from 'F5.00' ... 'F5.99' (slow ... fast) and confirm with *[Setup]*.

7.3 Operating mode 'Static Colour' (12×4W Quad IR RGBW)

This setting is only relevant if the device is working in Stand Alone mode and is not controlled via DMX. In this mode you have the option to select a solid colour for continuous operation and to set the flash frequency for all LEDs.

1. ➤ Press *[Mode]*, use *[Up]* and *[Down]* to select the menu option 'Colr' and confirm with *[Setup]*.
2. ➤ Use *[Up]* and *[Down]* to set the intensity for the red colour in a range from 'r.000' ... 'r.255' (bright ... dark) and confirm with *[Setup]*.
3. ➤ Use *[Up]* and *[Down]* to set the intensity for the green colour in a range from 'g.000' ... 'g.255' (bright ... dark) and confirm with *[Setup]*.
4. ➤ Use *[Up]* and *[Down]* to set the intensity for the blue colour in a range from 'b.000' ... 'b.255' (bright ... dark) and confirm with *[Setup]*.
5. ➤ Use *[Up]* and *[Down]* to set the intensity for the white colour in a range from 'u.000' ... 'u.255' (bright ... dark) and confirm with *[Setup]*.
6. ➤ Use *[Up]* and *[Down]* to set the frequency of the strobe effect in a range from 'F5.00' ... 'F5.99' (off, slow ... fast) and confirm with *[Setup]*.

7.4 Operating mode 'Static Colour' (12×3W Quad IR UV)

This setting is only relevant if the device is working in Stand Alone mode and is not controlled via DMX. In this mode you have the option to select a solid colour for continuous operation and to set the flash frequency for all LEDs.

1. ➤ Press *[Mode]*, use *[Up]* and *[Down]* to select the menu option 'Colr' and confirm with *[Setup]*.
2. ➤ Use *[Up]* and *[Down]* to set the brightness of the LEDs in a range from '1.000' ... '1.255' (bright ... dark) and confirm with *[Setup]*.
3. ➤ Use *[Up]* and *[Down]* to set the frequency of the strobe effect in a range from 'F5.00' ... 'F5.99' (off, slow ... fast) and confirm with *[Setup]*.

7.5 Operating mode 'DMX' (12×4W Quad IR RGBW)

This setting is only relevant if the device is controlled via a DMX controller.

1. ▶ Press *[Mode]*, use *[Up]* and *[Down]* to select the menu option 'DMX' and confirm with *[Setup]*.
2. ▶ Use *[Up]* and *[Down]* to assign a DMX address in the range from 'd.001' ... 'd.512' to the device and confirm with *[Setup]*.
3. ▶ Use *[Up]* and *[Down]* to select the desired DMX mode:

Mode	Display	Highest possible DMX address
4-channel	'4-ch'	509
6-channel	'6-ch'	507
8-channel	'8-ch'	505

4. ▶ Confirm twice with *[Setup]*.

7.5.1 Functions in 4-channel DMX mode

Channel	Value	Function
1	0...255	Intensity red (0 % to 100 %)
2	0...255	Intensity green (0 % to 100 %)
3	0...255	Intensity blue (0 % to 100 %)
4	0...255	Intensity white (0 % to 100 %)

7.5.2 Functions in 6-channel DMX mode

Channel	Value	Function
1	0...255	Dimmer (0 % to 100 %)
2	0...255	Intensity red (0 % to 100 %)
3	0...255	Intensity green (0 % to 100 %)

Channel	Value	Function
4	0...255	Intensity blue (0 % to 100 %)
5	0...255	Intensity white (0 % to 100 %)
6	0...255	Stroboscope effect (0 % to 100 %)

7.5.3 Functions in 8-channel DMX mode

Channel	Value	Function
1	0 ... 255	Dimmer (0 % to 100 %)
2	0 ... 255	Intensity red (0 % to 100 %), if channel 6 = 0 ... 35
3	0 ... 255	Intensity green (0 % to 100 %), if channel 6 = 0 ... 35
4	0 ... 255	Intensity blue (0 % to 100 %), if channel 6 = 0 ... 35
5	0 ... 255	Intensity white (0 % to 100 %), if channel 6 = 0 ... 35

Channel	Value	Function
6	Programme selection	
	0 ... 35	No function
	36 ... 71	Programme 01
	72 ... 107	Programme 02
	108 ... 143	Programme 03
	144 ... 179	Programme 04
	180 ... 215	Programme 05
	216 ... 251	Programme 06
	252 ... 255	Programme 07
7	Colour selection, if channel 6 = 36 ... 71	
	Speed, if channel 6 = 72 ... 255	
	0 ... 16	Blackout
	17 ... 33	Cyan

Channel	Value	Function
	34 ... 50	Purple
	51 ... 67	Pink
	68 ... 84	Orange
	85 ... 101	Cold white
	102 ... 118	Light red
	119 ... 135	Light green
	136 ... 152	Light blue
	153 ... 169	Yellow
	170 ... 186	Warm white
	187 ... 203	Red
	204 ... 220	Green
	221 ... 237	Blue
	238 ... 254	Amber

Outdoor Stage PAR 12 × 4W Quad IR RGBW, 12 × 3W Quad IR UV

Channel	Value	Function
	255	All
	0 ... 255	Programme progress speed
8	19 ... 255	Strobe effect

7.6 Operating mode 'DMX' (12×3W Quad IR UV)

This setting is only relevant if the device is controlled via a DMX controller.

1. ➤ Press *[Mode]*, use *[Up]* and *[Down]* to select the menu option 'DMX' and confirm with *[Setup]*.
2. ➤ Use *[Up]* and *[Down]* to assign a DMX address in the range from 'd.001' ... 'd.512' to the device and confirm with *[Setup]*.

3. ▶ Use *[Up]* and *[Down]* to select the desired DMX mode:

Mode	Display	Highest possible DMX address
1-channel	'1-ch'	512
2-channel	'2-ch'	511
5-channel	'5-ch'	508

4. ▶ Confirm twice with *[Setup]*.

7.6.1 Functions in 1-channel DMX mode

Channel	Value	Function
1	0...255	Intensity UV light (0 % to 100 %)

7.6.2 Functions in 2-channel DMX mode

Channel	Value	Function
1	0...255	Intensity UV light (0 % to 100 %)
2	0...255	Stroboscope effect (0 % to 100 %)

7.6.3 Functions in 5-channel DMX mode

Channel	Value	Function
1	0 ... 255	Dimmer (0 % to 100 %)
2	0 ... 255	Intensity UV light (0 % to 100 %)
3	10 ... 255	Fade in / out
4	0 ... 255	Programme speed (0 % to 100 %)
5	19 ... 255	Stroboscope effect (0 % to 100 %)

7.7 Operating mode 'Slave'

This setting is only relevant if the device is working as Slave in a Master / Slave configuration and is not controlled via DMX. To activate the operating mode, repeatedly press *[Mode]* until the display shows 'SLAV'.

7.8 Remote control (optional, 12×4W Quad IR RGBW)

The device can only be remote controlled if it's neither working in a Master / Slave configuration nor DMX-controlled.

Switching on / off

Use *[ON/OFF]* to turn the device on or off.

Operating mode 'Automatic'

Press *[AUTO]*. The playback of programmes 'Pr02' to 'Pr14' starts automatically.

Operating mode 'Preprogrammed automatic show'

Press *[PRO]*. Use *[+]* and *[-]* to select a value between 'Pr01' and 'Pr07'.

In the 'Preprogrammed automatic show' mode, you can activate the strobe effect. To do so, press *[STROBE]* and then use *[+]* and *[-]* to select a value between 'FS00' (slow) and 'FS99' (fast). Press *[STROBE]* again to disable the Strobe effect.

Dimming

Press *[Dimming]* to adjust the brightness of the primary colours. Press *[R]* (red), *[G]* (green) *[W]* (white) or *[B]* (blue) and then use *[+]* and *[-]* to select a value between 0 and 255.

Colour selection

You can use the coloured buttons to directly select a colour for programmes 'Pr01' and 'Pr09'. The following assignment applies:

Button	Colour	Button	Colour	Button	Colour
0	Cyan	5	Bright red	R	Red
1	Purple	6	Bright green	G	Green
2	Magenta	7	Bright blue	B	Blue
3	Orange	8	Yellow	A	Amber
4	Cold white	9	Warm white	W	White

Resetting to factory defaults

To reset the device to factory default settings, press [OFF] and the successively [9], [8] and [7].

7.9 Remote control (optional, 12×3W Quad IR UV)

The device can only be remote controlled if it's neither working in a Master / Slave configuration nor DMX-controlled.

Switching on / off

Use *[ON/OFF]* to turn the device on or off.

Operating mode 'Automatic'

Press *[AUTO]*. The playback of the programmes starts automatically.

Press *[SPEED]* and use *[+]* and *[-]* to set the programme speed in a range from 'SP01' (slow) to 'SPFL' (fast).

Press *[STROBE]* and use *[+]* and *[-]* to set the flash frequency in a range from 'FS00' (slow) to 'FS99' (fast). Press *[STROBE]* again to disable the Strobe effect.

Dimming

Press *[Dimming]* and set the brightness of the LED with *[+]* and *[-]* in a range from '1.000' to '1.255'.

Resetting to factory defaults

To reset the device to factory default settings, press *[OFF]* and the successively *[9]*, *[8]* and *[7]*.

8 Technical specifications

	Outdoor Stage Par 12×4W Quad IR RGBW	Outdoor Stage Par 12×3W Quad IR UV
Item no.	387902	387911
LED configuration:	12 × Quad IR RGBW LED, 4 W	12 × Quad IR UV LED, 3 W
Number of DMX channels:	4, 6, 8	1, 2, 5
Beam angle	25 °	
DMX input, DMX output	XLR 3-pin	
Power consumption	61 W	47 W
Operating supply voltage	100 – 240 V ~ 50/60 Hz	
Protection class	IP65	
Permitted ambient temperature	–20 ... 40 °C	

	Outdoor Stage Par 12×4W Quad IR RGBW	Outdoor Stage Par 12×3W Quad IR UV
Dimensions (W × H × D)	184 mm × 184 mm × 170 mm	
Weight	3.5 kg	

Outdoor Stage PAR 12 × 4W Quad IR RGBW, 12 × 3W Quad IR UV

9 Plug and connection assignments

Introduction

This chapter will help you select the right cables and plugs to connect your valuable equipment so that a perfect light experience is guaranteed.

Please take our tips, because especially in 'Sound & Light' caution is indicated: Even if a plug fits into a socket, the result of an incorrect connection may be a destroyed DMX controller, a short circuit or 'just' a not working light show!

DMX connections

The unit offers a 3-pin XLR socket for DMX output and a 3-pin XLR plug for DMX input. Please refer to the drawing and table below for the pin assignment of a suitable XLR plug.



Pin	Configuration
1	Ground, shielding
2	Signal inverted (DMX-, 'cold signal')
3	Signal (DMX+, 'hot signal')

10 Troubleshooting



NOTICE!

Possible data transmission errors

For error-free operation make use of dedicated DMX cables and do not use ordinary microphone cables.

Never connect the DMX input or output to audio devices such as mixers or amplifiers.

In the following we list a few common problems that may occur during operation. We give you some suggestions for easy troubleshooting:

Symptom	Remedy
The unit does not work, no light.	Check the mains connection and the fuse.
No response to the DMX controller.	1. Check the DMX ports and cables for proper connection.
	2. Check the address settings and the DMX polarity.
	3. Try using another DMX controller.
	4. Check to see if the DMX cables run near or alongside to high voltage cables that may cause damage or interference to DMX interface circuits.

If the procedures recommended above do not succeed, please contact our Service Center. You can find the contact information at www.thomann.de.

11 Cleaning

Optical lenses

Clean the optical lenses, that are accessible from the outside, regularly in order to optimize the light output. The frequency of cleaning depends on the operating environment: wet, smoky or particularly dirty surroundings can cause more accumulation of dirt on the optics of the device.

- Clean with a soft cloth using our lamp and lens cleaner (item no. 280122).
- Always dry the parts carefully.

12 Protecting the environment

Disposal of the packaging material



For the transport and protective packaging, environmentally friendly materials have been chosen that can be supplied to normal recycling.

Ensure that plastic bags, packaging, etc. are properly disposed of.

Do not just dispose these materials with your normal household waste, but make sure that they are fed to a recovery. Please follow the notes and markings on the packaging.

Disposal of batteries



Batteries must not be disposed of as domestic waste or thrown into fire. Dispose of the batteries according to national or local regulations regarding hazardous waste. To protect the environment, dispose of empty batteries at your retail store or at appropriate collection sites.

Disposal of your old device



This product is subject to the European Waste Electrical and Electronic Equipment Directive (WEEE). Do not dispose with your normal household waste.

Dispose this device through an approved waste disposal firm or through your local waste facility. When discarding the device, comply with the rules and regulations that apply in your country. If in doubt, consult your local waste disposal facility.



