



TL 110

active subwoofer

Musikhaus Thomann
Thomann GmbH
Hans-Thomann-Straße 1
96138 Burgebrach
Germany
Telephone: +49 (0) 9546 9223-0
E-mail: info@thomann.de
Internet: www.thomann.de

29.03.2019, ID: 452287

Table of contents

1	General information	4
	1.1 Further information.....	5
	1.2 Notational conventions.....	6
	1.3 Symbols and signal words.....	6
2	Safety instructions	8
3	Features	14
4	Installation	15
	4.1 Mounting variants.....	17
	4.2 Tips on handling speakers.....	22
5	Connections and operating elements	23
6	Technical specifications	26
7	Plug and connection assignment	29
8	Protecting the environment	32

1 General information

This user manual contains important information on the safe operation of the device. Read and follow all safety notes and all instructions. Save this manual for future reference. Make sure that it is available to all persons using this device. If you sell the device to another user, be sure that they also receive this manual.

Our products and user manuals are subject to a process of continuous development. We therefore reserve the right to make changes without notice. Please refer to the latest version of the user manual which is ready for download under www.thomann.de.

1.1 Further information

On our website (www.thomann.de) you will find lots of further information and details on the following points:

Download	This manual is also available as PDF file for you to download.
Keyword search	Use the search function in the electronic version to find the topics of interest for you quickly.
Online guides	Our online guides provide detailed information on technical basics and terms.
Personal consultation	For personal consultation please contact our technical hotline.
Service	If you have any problems with the device the customer service will gladly assist you.

1.2 Notational conventions

This manual uses the following notational conventions:

Letterings

The letterings for connectors and controls are marked by square brackets and italics.

Examples: *[VOLUME]* control, *[Mono]* button.

1.3 Symbols and signal words

In this section you will find an overview of the meaning of symbols and signal words that are used in this manual.

Signal word	Meaning
DANGER!	This combination of symbol and signal word indicates an immediate dangerous situation that will result in death or serious injury if it is not avoided.
CAUTION!	This combination of symbol and signal word indicates a possible dangerous situation that can result in minor injury if it is not avoided.
NOTICE!	This combination of symbol and signal word indicates a possible dangerous situation that can result in material and environmental damage if it is not avoided.
Warning signs	Type of danger
	Warning – high-voltage.
	Warning – danger zone.

2 Safety instructions

Intended use

This device is designed for sound reinforcement. Use the device only as described in this user manual. Any other use or use under other operating conditions is considered to be improper and may result in personal injury or property damage. No liability will be assumed for damages resulting from improper use.

This device may be used only by persons with sufficient physical, sensorial, and intellectual abilities and having corresponding knowledge and experience. Other persons may use this device only if they are supervised or instructed by a person who is responsible for their safety.

Safety



DANGER!

Danger for children

Ensure that plastic bags, packaging, etc. are disposed of properly and are not within reach of babies and young children. Choking hazard!

Ensure that children do not detach any small parts (e.g. knobs or the like) from the unit. They could swallow the pieces and choke!

Never let children unattended use electrical devices.



DANGER!

Electric shock caused by high voltages inside

Within the device there are areas where high voltages may be present. Never remove any covers.

There are no user-serviceable parts inside.

Do not use the device if covers, protectors or optical components are missing or damaged.



DANGER!

Electric shock caused by short-circuit

Always use proper ready-made insulated mains cabling (power cord) with a protective contact plug. Do not modify the mains cable or the plug. Failure to do so could result in electric shock/death or fire. If in doubt, seek advice from a registered electrician.



CAUTION!

Possible hearing damage

The device can produce volume levels that may cause temporary or permanent hearing impairment. Over an extended period of time, even levels that seem to be uncritical can cause hearing damage.

Decrease the volume level immediately if you experience ringing in your ears or hearing impairment. If this is not possible, keep a greater distance or use sufficient ear protectors.



NOTICE!

Risk of fire

Do not block areas of ventilation. Do not install the device near any direct heat source. Keep the device away from naked flames.

**NOTICE!****Operating conditions**

This device has been designed for indoor use only. To prevent damage, never expose the device to any liquid or moisture. Avoid direct sunlight, heavy dirt, and strong vibrations.

Only operate the device within the ambient conditions specified in the chapter 'Technical specifications' of this user manual. Avoid heavy temperature fluctuations and do not switch the device on immediately after it was exposed to temperature fluctuations (for example after transport at low outside temperatures).

Dust and dirt inside can damage the unit. When operated in harmful ambient conditions (dust, smoke, nicotine, fog, etc.), the unit should be maintained by qualified service personnel at regular intervals to prevent overheating and other malfunction.



NOTICE!

Possible staining

The plasticiser contained in the rubber feet of this product may possibly react with the coating of your parquet, linoleum, laminate or PVC floor and after some time cause permanent dark stains.

In case of doubt, do not put the rubber feet directly on the floor, but use felt-pad floor protectors or a carpet.



NOTICE!

Power supply

Before connecting the device, ensure that the input voltage (AC outlet) matches the voltage rating of the device and that the AC outlet is protected by a residual current circuit breaker. Failure to do so could result in damage to the device and possibly injure the user.

Unplug the device before electrical storms occur and when it is unused for long periods of time to reduce the risk of electric shock or fire.



NOTICE!

Possible damage due to installation of a wrong fuse

The use of different types of fuses can cause serious damage to the unit. Fire hazard!

Only fuses of the same type may be used.

3 Features

Special features of the device:

- Active subwoofer with DSP
- Inputs: 1 × XLR combo socket
- Outputs: 2 × XLR chassis socket, 1 × Speaker Twist
- 10" woofer
- Built-in limiter circuit
- Speaker flange 25 mm
- Connection of top units and bass possible via TL click system

4 Installation

Unpack and check carefully there is no transportation damage before using the unit. Keep the equipment packaging. To fully protect the product against vibration, dust and moisture during transportation or storage use the original packaging or your own packaging material suitable for transport or storage, respectively.

For operation, the device must be placed on the rubber feet from the side provided with a protective edge. Do not operate the device when it is standing on the casters. There is a risk of overheating and the possibility that the device may move uncontrolled on the casters.

Create all connections while the device is off. Use the shortest possible high-quality cables for all connections. Take care when running the cables to prevent tripping hazards.



CAUTION!

Risk of injury due to heavy weight

Due to the heavy weight of the device, at least two persons are required for transport and installation.



NOTICE!

Possible property damage by magnetic fields

Loudspeakers produce a static magnetic field. Therefore, maintain an appropriate distance to devices that can be adversely affected or damaged by an external magnetic field.

4.1 Mounting variants

The box pro TL system consists of the subwoofer the box pro TL 110 (item number 452287), the column speaker the box pro TL 63 (item number 452285), and the speaker pole the box pro TL Pole (item number 452289). The individual elements can be connected to each other with the TL click system. The following mounting variants are possible:

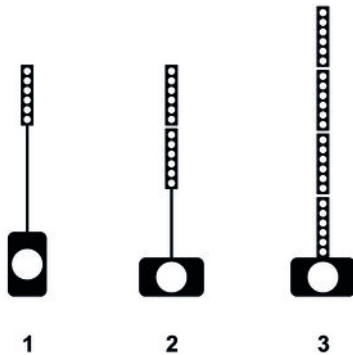

1	1 × the box pro TL 110, 1 × the box pro TL 63, 1 × the box pro TL Pole
2	1 × the box pro TL 110, 2 × the box pro TL 63, 1 × the box pro TL Pole
3	1 × the box pro TL 110, 4 × the box pro TL 63

Connecting the subwoofer directly to the column speaker

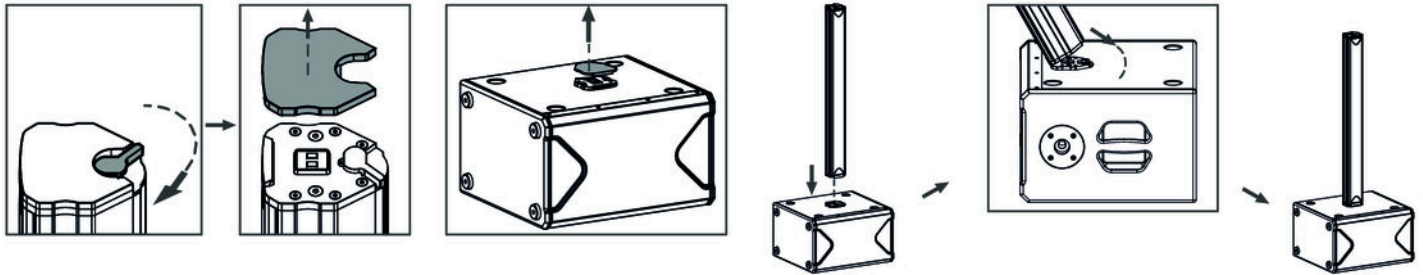

1. ➤ Activate the positioner by pressing the release button on the head of the column speaker.
2. ➤ Release the protective cap on top of the column speaker by turning the lever.
3. ➤ Remove the protective cap on top of the column speaker.
4. ➤ Remove the protective cap from the side of the subwoofer.

5. ▶ Place the column speaker on the subwoofer. Make sure that the connector sockets are positioned exactly on top of each other.
⇒ The positioner will lock in place. The column speaker is connected to the subwoofer.

Connecting column loudspeakers to each other

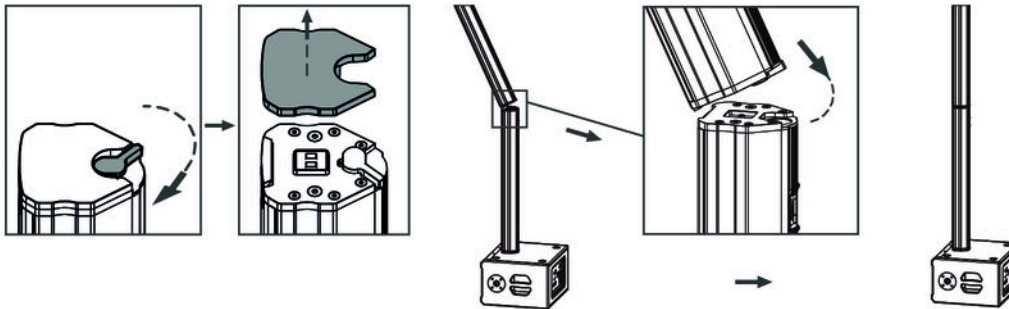

1. ▶ Activate the positioner by pressing the release button on the head of the column speaker.
2. ▶ Release the protective cap on top of the column speaker by turning the lever.

3. ➤ Remove the protective cap on top of the column speaker.
4. ➤ Repeat steps 1 to 3 for the second column speaker.
5. ➤ Place the first column speaker on the second column speaker. Make sure that the connector sockets are positioned exactly on top of each other.
 - ⇒ The positioner will lock in place. The column speakers are connected to each other.

Connecting the subwoofer to the column speaker via speaker pole

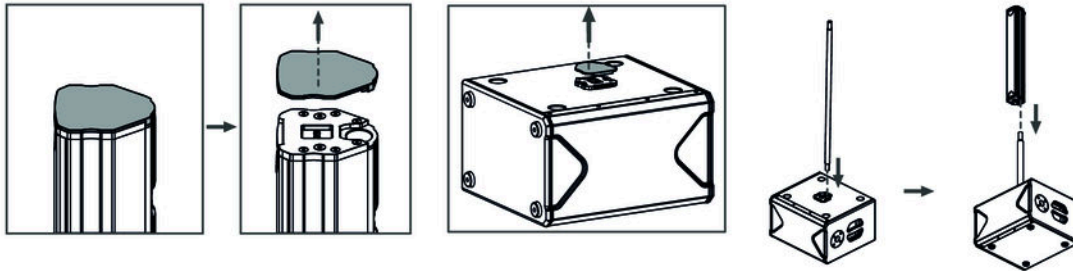

- 1.** ▶ Activate the positioner by pressing the release button on the head of the column speaker.
- 2.** ▶ Release the protective cap on top of the column speaker by turning the lever.
- 3.** ▶ Remove the protective cap on top of the column speaker.
- 4.** ▶ Remove the protective cap from the side of the subwoofer.
- 5.** ▶ Insert the speaker pole into the flange of the subwoofer.
- 6.** ▶ Place the column speaker with the 25 mm speaker flange on the speaker pole.
- 7.** ▶ Connect the subwoofer and column speaker with a speaker twist cable.
 - ⇒ Subwoofer and column speaker are now connected to each other.

4.2 Tips on handling speakers

We recommend you to set up the speakers in a way, that the sound signals can reach the audience unobstructedly. It will often be helpful to mount the speakers on tripods. Thus, the sound will be evenly spread with maximum range throughout the audience area.

Always use high grade cable to connect your equipment. Otherwise you won't reach maximum sound quality.

For optimum results both impedance and power handling of the speakers must match the requirements of the amplifier. Always follow the technical specifications of the speakers! The overall impedance of the connected loudspeakers must not exceed the minimum output impedance of the amp. The amps max. RMS output power should be 50 % above the power handling capacity of the connected speakers.

If you notice distortion during operation, either the amp or the speaker is overloaded. This may permanently damage the amp or the speaker. Always reduce the volume when you hear distortion.

5 Connections and operating elements

Rear panel

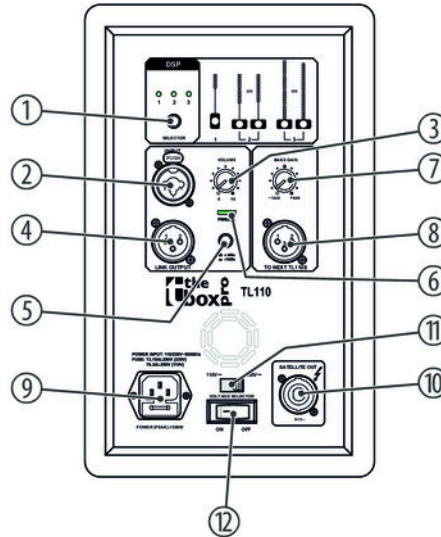

TL 110

1	<i>[DSP SELECTOR]</i> DSP selector switch to select mounting variants 1 ... 3. The LED of the selected mounting variant lights up.
2	<i>[INPUT]</i> Line input, designed as XLR combo socket.
3	<i>[VOLUME]</i> Rotary volume control
4	<i>[LINK OUTPUT]</i> Signal output for connection to another active bass module, designed as 3-pin XLR socket.
5	<i>[GAIN]</i> Button pressed: -10 dBu Button not pressed: +4 dBu
6	<i>[PWR/LIM]</i> Power supply / limiter indication LED lights up green: The unit is powered. LED lights up red: The signal is overdriven.

7	<i>[BASS GAIN]</i> Increases or decreases the bass level in relation to the overall signal in the range of -12 dB ... +6 dB.
8	<i>[TO NEXT TL 110S]</i> Output socket for connection to another bass module, designed as 3-pin XLR socket.
9	Plug for mains cable with fuse holder
10	Speaker Twist chassis connector for connecting a column speaker
11	Mains voltage selector
12	Main switch. Turns the device on and off.

6 Technical specifications

Speaker		1 × 10" woofer
Input connections	Voltage supply	IEC chassis plug C14
	Line in	1 × XLR combo socket
Output connections	Connection of additional sub-woofers	1 × XLR chassis socket, 3-pin
	Line Out	1 × XLR chassis socket, 3-pin
	Connection mid-range speaker/tweeter	1 × speaker twist output socket
Output power		RMS: 250 W Sub RMS: 250 W mid-range speaker/tweeter Peak: 1500 W
Frequency range		50 Hz ... 200 Hz, -10 dB
Crossover frequency		200 Hz, 24 dB

Sound pressure level (SPL), max.	115 dB	
Supply voltage	AC 100/230 V ~ 50/60 Hz	
Fuse	230 V: 5 mm × 20 mm, 3,15 A, 250 V, slow-blow	
	110 V: 5 mm × 20 mm, 6,3 A, 250 V, slow-blow	
Mounting options	Speaker flange 25 mm	
Dimensions (W × H × D)	500 mm × 450 mm × 310 mm	
Weight	17 kg	
Ambient conditions	Temperature range	0 °C...40 °C
	Relative humidity	50 %, non-condensing

Further information

Design	Bandpass filter
Truss-capable	No
Stand mounting	Yes
Casters	No
Built-in mixer	No
Housing colour	Black
Housing material	Multilayer plywood

7 Plug and connection assignment

Introduction

This chapter will help you select the right cables and plugs to connect your valuable equipment in such a way that a perfect sound experience is ensured.

Please note these advices, because especially in 'Sound & Light' caution is indicated: Even if a plug fits into the socket, an incorrect connection may result in a destroyed power amp, a short circuit or 'just' in poor transmission quality!

Balanced and unbalanced transmission

Unbalanced transmission is mainly used in semi-professional environment and in hifi use. Instrument cables with two conductors (one core plus shielding) are typical representatives of the unbalanced transmission. One conductor is ground and shielding while the signal is transmitted through the core.

Unbalanced transmission is susceptible to electromagnetic interference, especially at low levels, such as microphone signals and when using long cables.

In a professional environment, therefore, the balanced transmission is preferred, because this enables an undisturbed transmission of signals over long distances. In addition to the conductors 'Ground' and 'Signal', in a balanced transmission a second core is added. This also transfers the signal, but phase-shifted by 180°.

Since the interference affects both cores equally, by subtracting the phase-shifted signals, the interfering signal is completely neutralized. The result is a pure signal without any noise interference.

1/4" TS phone plug (mono, unbalanced)



1	Signal
2	Ground, shielding

1/4" TRS phone plug (mono, balanced)



1	Signal (in phase, +)
2	Signal (out of phase, -)
3	Ground

XLR plug (balanced)

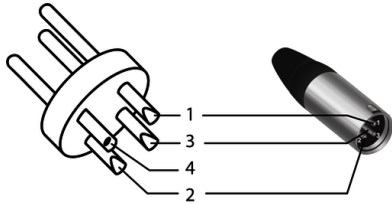

1	Ground, shielding
2	Signal (in phase, +)
3	Signal (out of phase, -)
4	Shielding on plug housing (option)

Speaker Twist chassis connector



1, +	Signal 1 (in phase)
1, -	Signal 1 (out of phase)
2, +	Signal 2 (in phase)
2, -	Signal 2 (out of phase)

8 Protecting the environment

Disposal of the packaging material



For the transport and protective packaging, environmentally friendly materials have been chosen that can be supplied to normal recycling.

Ensure that plastic bags, packaging, etc. are properly disposed of.

Do not just dispose of these materials with your normal household waste, but make sure that they are collected for recycling. Please follow the notes and markings on the packaging.

Disposal of your old device



This product is subject to the European Waste Electrical and Electronic Equipment Directive (WEEE) in its currently valid version. Do not dispose with your normal household waste.

Dispose of this device through an approved waste disposal firm or through your local waste facility. When discarding the device, comply with the rules and regulations that apply in your country. If in doubt, consult your local waste disposal facility.

TL 110



