

# PEARL DRUM PEDAL

## P-3000D

### Instruction Manual

Congratulations on your purchase!  
To get optimum performance of your "P-3000D" Drum Pedal,  
please read this Instruction Manual before playing.

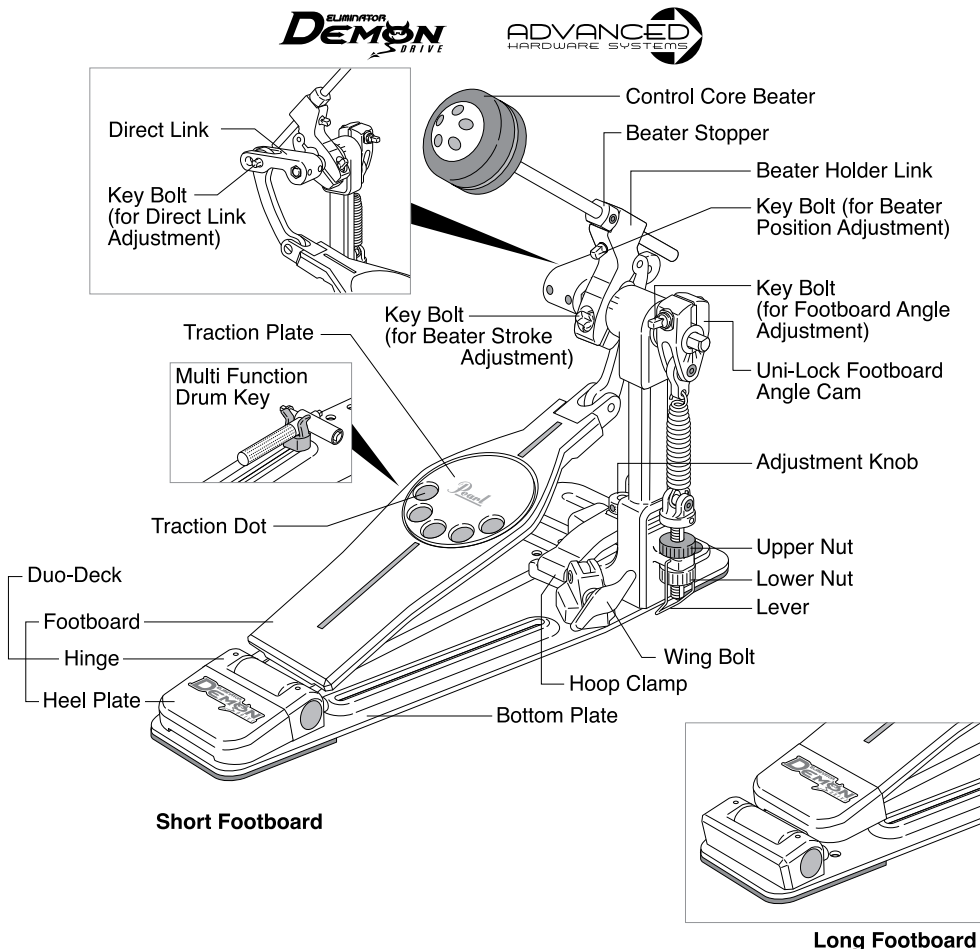

#### Attachments

NiijA Oil, Velcro Tape (x3), Allen Wrench (4mm, 3mm, 2.5mm)

## Control Core Beater Setting

Insert the Control Core Beater into the Beater Holder Link until it stops against the Beater Setting Stopper, and tighten the key bolt with the provided Multi Function Drum Key (Fig.1-A). Make sure that the Beater Setting Stopper is flush against the Beater Holder Link with the flat face square against the Notch (Fig.1-B).

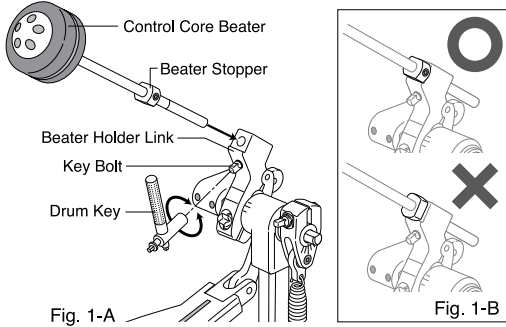

### Note

You'll notice that the Index Mark is centered in the Window as shown (Fig. 2). The initial setting is where this Index Mark and the line on the shaft is aligned.

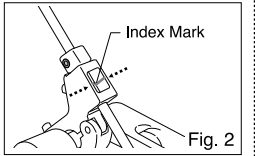

To change to a higher or shorter beater height, loosen the Allen screw on the Beater Setting Stopper with the provided Multi-Function Drum Key or Allen wrench(3mm) then loosen the Key Bolt on the Beater Holder Link (Fig. 3). Set the beater to the desired height and re-tighten the Key Bolt. Reset the Beater Setting Stopper flush against the Beater Holder Link per the instructions above.

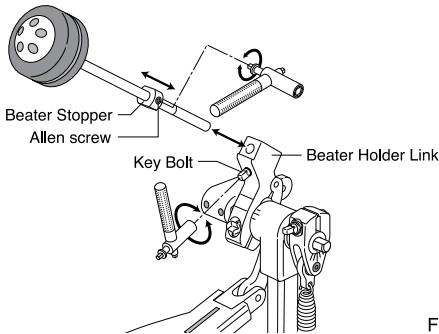

### Note

The Beater Setting Stopper preserves the height setting if the beater is removed when transporting the pedal.

## Beater Stroke Adjustment

The P-3000D Demon Drive Pedal features our exclusive two-position Beater Holder that can be positioned closer or further from the drum head for Finesse "A" Position setting or Power "B" Position setting respectively.

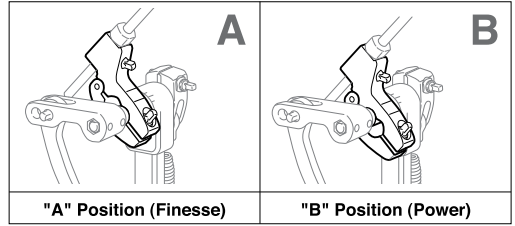

It also rotates infinitely for perfect beater angle without changing the footboard height.

### Note

The Beater Holder is set at the factory in the Finesse "A" Position.

## Changing the Beater Holder Position

To change to Power setting, loosen the Key Bolt to open the clamp and slide the Beater Holder to the Power setting position (Fig.4-A, 4-B). There is no need to remove the key bolt from the clamp.

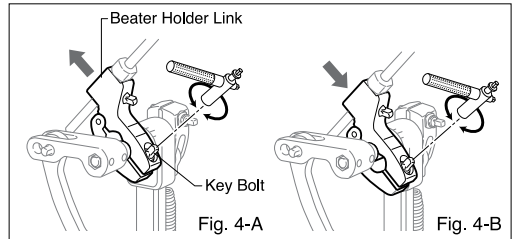

## Beater Angle Adjustment

To change the angle of the beater, loosen the Key Bolt and set the angle to your preference and re-tighten the Key Bolt (Fig.5).

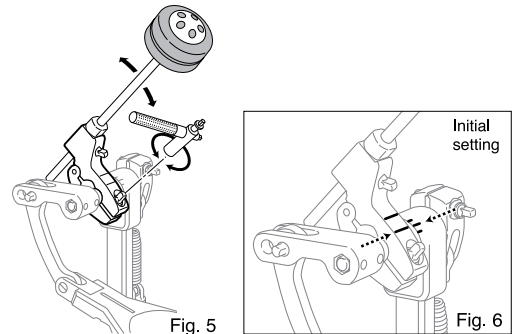

### Note

Indicator marks are provided for referencing beater angle settings (Fig.6).

## Direct Link Adjustment

The Direct Link can be adjusted to provide a Heavier or a Lighter feel.

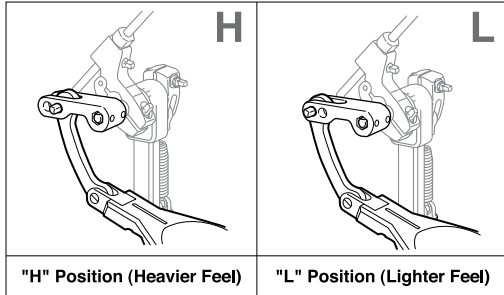

"H" Position (Heavier Feel)

"L" Position (Lighter Feel)

### Note

The Direct Link is set at the factory in the Heavier Feel "H" Position.

To change to a Lighter feel, remove the Key Bolt with the Multi-Function Drum Key as shown. Move the Direct Link to the forward set of holes and re-attach the Key Bolt. To change back to a Heavier feel, remove the Key Bolt and attach the Direct Link to the rear set of holes (Fig. 7-A, 7-B).

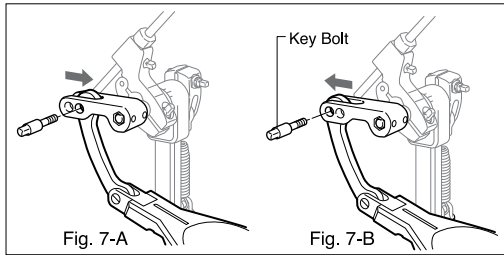

Fig. 7-A

Fig. 7-B

## Footboard Angle Adjustment

The Footboard Angle can be adjusted by loosening the Key Bolt on the Uni-Lock Footboard Angle Cam and adjusting it to the desired angle (Fig.8-A). Re-tighten the key bolt to secure the angle. A gauge on the side of the Angle Cam is provided to reference Footboard angle settings (Fig.8-B).

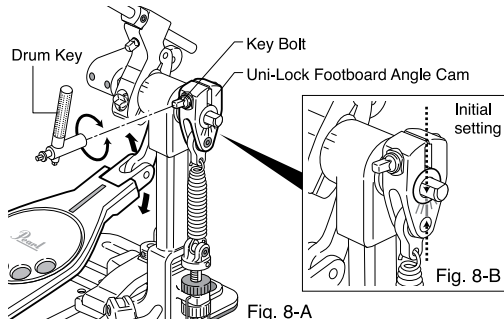
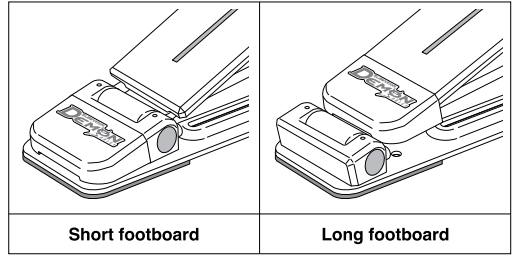

Fig. 8-A

Fig. 8-B

## Duo-Deck Footboard

The P-3000D features the Duo-Deck Footboard, the world's first convertible Short / Long footboard.



Short footboard

Long footboard

### Note

The Duo-Deck is set at the factory in the Short-Board setting.

To convert the Duo-Deck to a Long-Board, turn the pedal over and remove the four Flat Head Screws with the provided Multi-Function Drum Key or Allen wrench(3mm) as shown and remove the Heel Plate and the Hinge from the Bottom Plate (Fig.9).

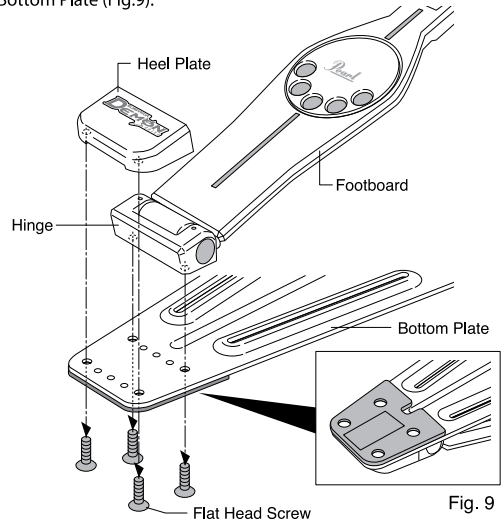

Fig. 9

Lift the footboard and remove the four 3-piece screws with the provided Multi-Function Drum Key or Allen wrench (3mm) as shown, and remove the Hinge from the Footboard (Fig.10).

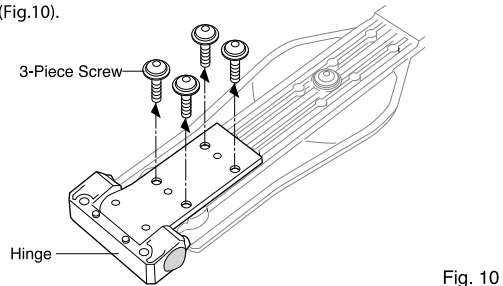

Fig. 10

Reattach the Hinge to the Footboard in the position shown with two 3-Piece Screws using the provided Multi-Function drum key or Allen wrench(3mm) (Fig.11).

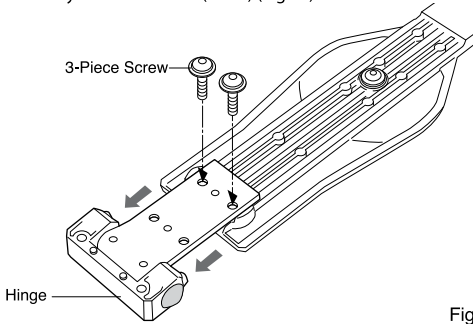

Fig. 11

Place the Heel Plate between the Footboard and the Hinge (Fig.12) and attach the Heel Plate with the remaining two 3-Piece screws using the Mutli-Function Drum Key or Allen wrench(3mm). Attach the Hinge to the Bottom Plate with the Flat Head Screw using the Multi-Function Drum Key or Allen wrench(3mm) (Fig.12). The Hinge is now located at the back of the Footboard to achieve a Long-Board.

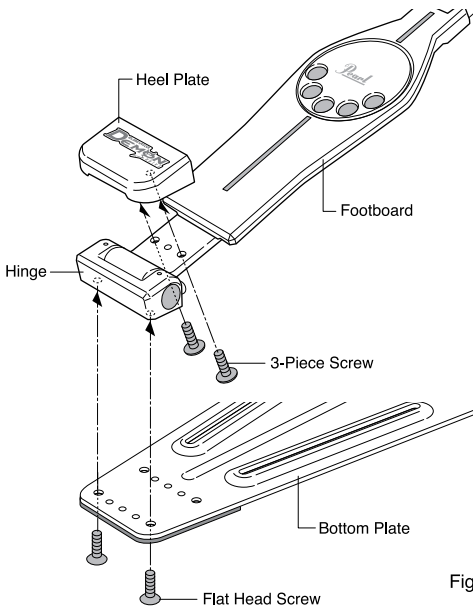



Fig. 12

**CAUTION**

The Duo-Deck Footboard uses two different types of screws. Make sure to use the correct screws.



Flat Head Screw



3-Piece Screw

## Spring Tension Adjustment

The P-3000D Demon Drive Pedals feature our exclusive Click Lock spring tension retention system. To increase the spring tension, disable the Click Lock by lifting the lever upward, loosen the Upper Nut and tighten the Lower Nut until the desired tension is achieved (Fig.13-A). To decrease spring tension, disable the Click Lock by lifting the lever upward, loosen the Upper Nut and loosen the Lower Nut until the desired tension is achieved. When the desired spring tension is achieved, tighten the Upper Nut to keep the spring tension from loosening then press the Click Lock lever down to engage the grooves around the Lower Nut until you feel the lever "Click" (Fig.13-B). Before playing, make sure that both Upper and Lower Nuts are tight and the Click Lock lever is in a vertical position with both sides of the lever engaged in the grooves around the Lower Nut.

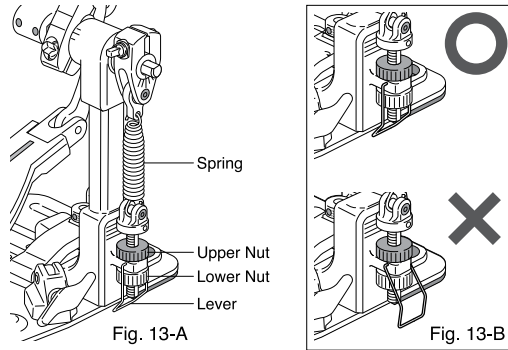

Fig. 13-A

Fig. 13-B

## Hoop Clamp System

The P-3000D Hoop Clamp System is designed with Spherical Rubber Grips allowing the front of the bass drum to be raised while keeping the pedal flush on the floor. Insert the bass drum hoop into the clamp, and turn the wing bolt to secure.

The clamp comes preset from the factory to accommodate most bass drum hoops but if necessary it can be adjusted to fit thicker or narrower hoops. Loosen the Allen screw on the Adjustment Knob with the provided Allen wrench (2.5mm) as shown and tighten or loosen the Adjustment Knob until proper fit is achieved then re-tighten the Allen screw (Fig.14). If the heel plate of the pedal lifts while playing, try loosening the Adjustment Knob to change the angle of the Hoop Clamp until the pedal remains flat.

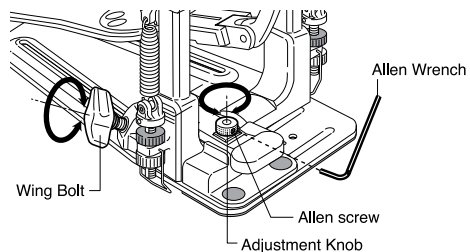

Fig. 14

Reattach the Hinge to the Footboard in the position shown with two 3-Piece Screws using the provided Multi-Function drum key or Allen wrench(3mm) (Fig.11).

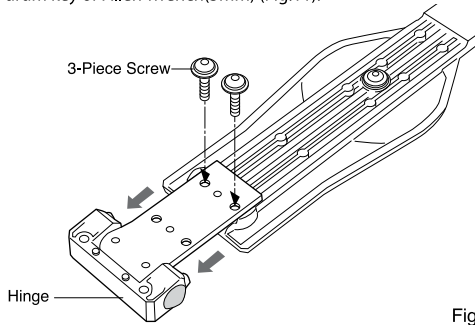

Fig. 11

Place the Heel Plate between the Footboard and the Hinge (Fig.12) and attach the Heel Plate with the remaining two 3-Piece screws using the Mutli-Function Drum Key or Allen wrench(3mm). Attach the Hinge to the Bottom Plate with the Flat Head Screw using the Multi-Function Drum Key or Allen wrench(3mm) (Fig.12). The Hinge is now located at the back of the Footboard to achieve a Long-Board.

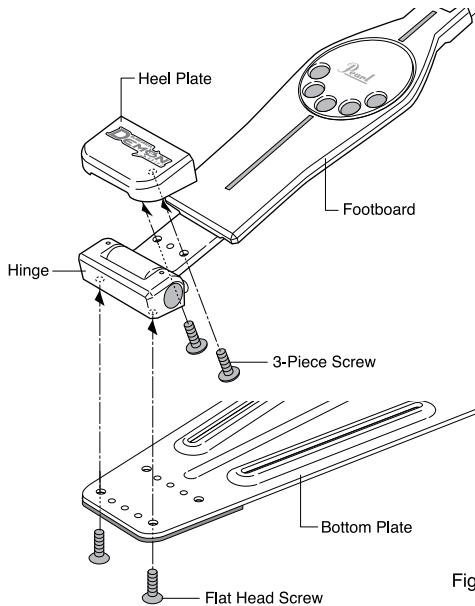



Fig. 12

**CAUTION**  
The Duo-Deck Footboard uses two different types of screws. Make sure to use the correct screws.

	
Flat Head Screw	3-Piece Screw

## Spring Tension Adjustment

The P-3000D Demon Drive Pedals feature our exclusive Click Lock spring tension retention system. To increase the spring tension, disable the Click Lock by lifting the lever upward, loosen the Upper Nut and tighten the Lower Nut until the desired tension is achieved (Fig.13-A). To decrease spring tension, disable the Click Lock by lifting the lever upward, loosen the Upper Nut and loosen the Lower Nut until the desired tension is achieved. When the desired spring tension is achieved, tighten the Upper Nut to keep the spring tension from loosening then press the Click Lock lever down to engage the grooves around the Lower Nut until you feel the lever "Click" (Fig.13-B). Before playing, make sure that both Upper and Lower Nuts are tight and the Click Lock lever is in a vertical position with both sides of the lever engaged in the grooves around the Lower Nut.

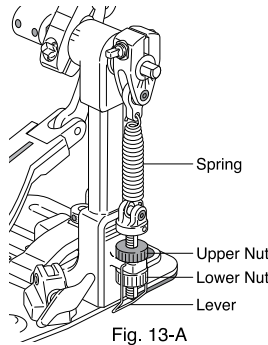

Fig. 13-A

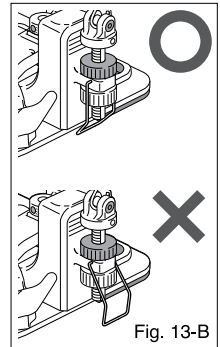

Fig. 13-B

## Hoop Clamp System

The P-3000D Hoop Clamp System is designed with Spherical Rubber Grips allowing the front of the bass drum to be raised while keeping the pedal flush on the floor. Insert the bass drum hoop into the clamp, and turn the wing bolt to secure.

The clamp comes preset from the factory to accommodate most bass drum hoops but if necessary it can be adjusted to fit thicker or narrower hoops. Loosen the Allen screw on the Adjustment Knob with the provided Allen wrench (2.5mm) as shown and tighten or loosen the Adjustment Knob until proper fit is achieved then re-tighten the Allen screw (Fig.14). If the heel plate of the pedal lifts while playing, try loosening the Adjustment Knob to change the angle of the Hoop Clamp until the pedal remains flat.

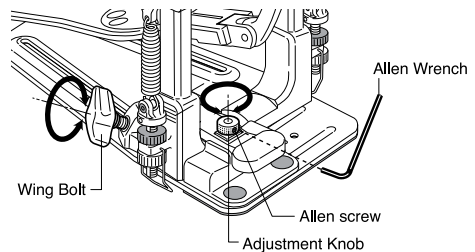

Fig. 14

## Traction Plate / Traction Dots

The Traction Plate adjusts to a variety of grip/slide configurations. To change the position of the Traction Dots, use the Multi-Function Drum Key or Allen wrench(3mm) to remove the 3-Piece Screw beneath the footboard and remove the Traction Plate (Fig.15). Rearrange the Traction Dots to your preference and replace the Traction Plate.

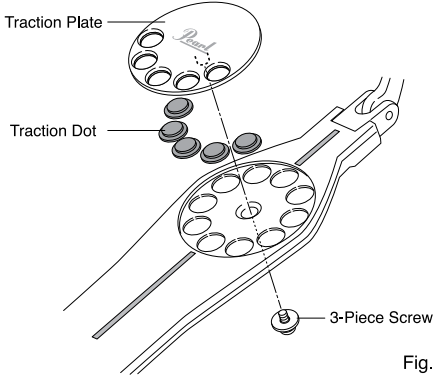
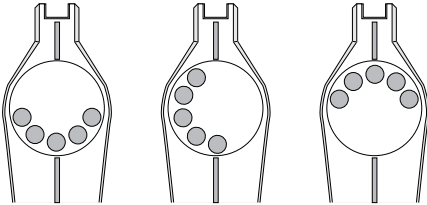

Fig. 15

### Note

#### Setting Examples



The Aluminum Traction Dots can be replaced with optional NP-283N/7 Rubber Dots for more traction.

## Velcro Strips for Slip Prevention

Velcro Strips are provided with the P-3000D pedal to help prevent slipping when used on carpeted floors. To apply, peel off the backing on the Velcro Strips and apply them in the locations shown. Clean the surfaces thoroughly with alcohol and dry completely for best adhesion (Fig.16).

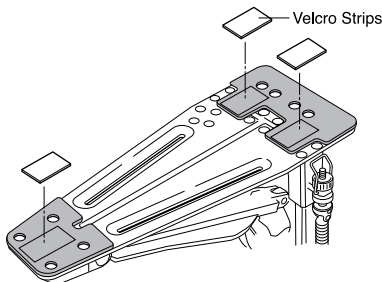
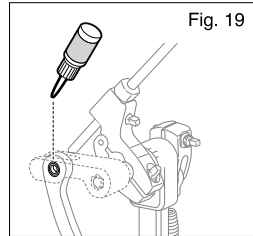
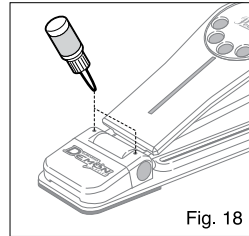
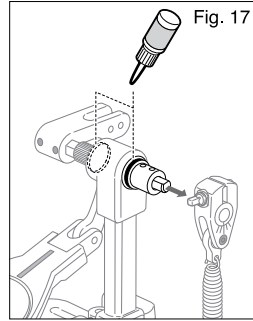

Fig. 16

## NiNJA™ Oil

The P-3000D features precision NiNJA bearings for incredible speed and smoothness. To keep them functioning at their maximum speed and performance it's recommended that you apply genuine NiNJA Oil at regular intervals (Fig.17). NiNJA Oil is also ideal for use on footboard hinges and Direct Link bearing to maintain "like-new" performance (Fig.18, 19).



### CAUTION

Do not apply other than genuine NiNJA Oil.

## Optional Items (sold separately)

- Control Core Wood Beater (B-300W)
- Traction Rubber Grip (NP-283N/7)

### CAUTION

- ◆ Check all Key Bolts and Allen screws for tightness before performance, and tighten them with the provided Multi-Function Drum Key or Allen wrenches as needed.

**Pearl**

<http://www.pearldrums.com>

Products and specifications are subject to change without notice.

Printed in Taiwan.

-0901-