

# Pressure Points

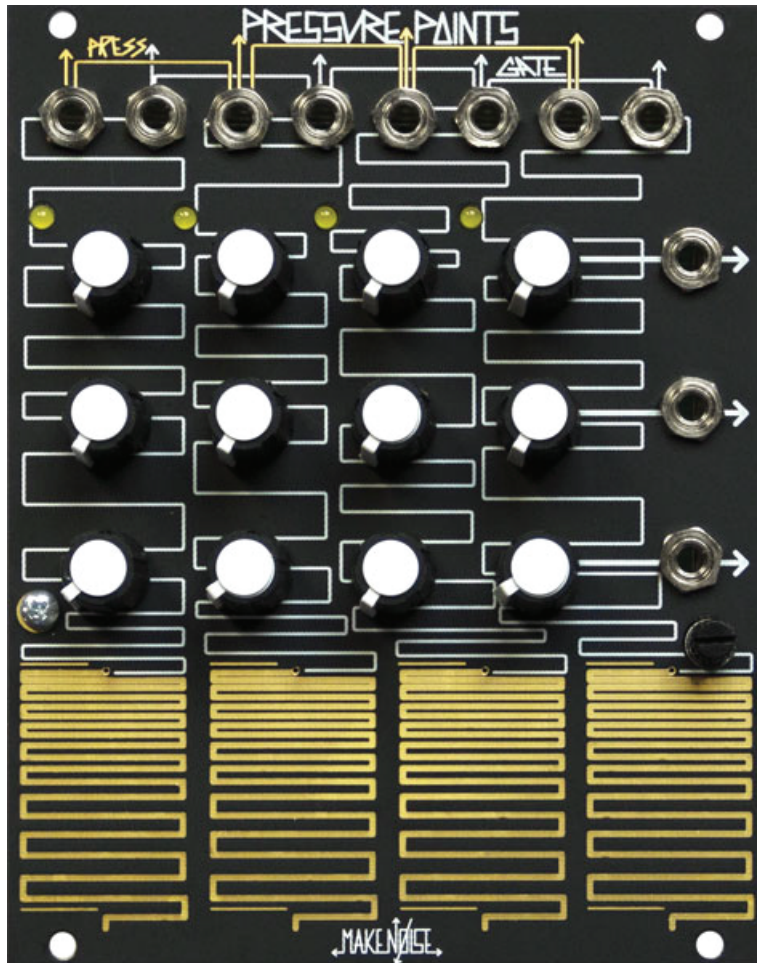

v. 2.4

**Pressure Points**

FCC:-----2  
Limited Warranty: -----3  
Installation: -----4  
Jumper and Cable Connections: -----5  
Panel Controls: -----7  
Overview:-----8  
Tips & Tricks: -----9

---



This device complies with Part 15 of the FCC Rules. Operation is subject to the following two conditions: (1) this device may not cause harmful interference, and (2) this device must accept any interference received, including interference that may cause undesired operation.

Changes / modifications not approved by the Make Noise Co. could void the user's authority to operate the equipment.

This equipment has been tested and found to comply with the limits for a Class A digital device, pursuant to part 15 of the FCC Rules. These limits are designed to provide reasonable protection against harmful interference when the equipment is operated in a commercial environment. This equipment generates, uses, and can radiate radio frequency energy and, if not installed and used in accordance with the instruction manual, may cause harmful interference to radio communications.

[makenoisemusic.com](http://makenoisemusic.com)

Make Noise Co., 414 Haywood Road, Asheville, NC 28806

Make Noise warrants this product to be free of defects in materials or construction for a period of one year from the date of purchase (proof of purchase/invoice required).

Malfunction resulting from wrong power supply voltages, backwards or reversed eurorack bus board cable connection, abuse of the product or any other causes determined by Make Noise to be the fault of the user are not covered by this warranty, and normal service rates will apply.

During the warranty period, any defective products will be repaired or replaced, at the option of Make Noise, on a return-to-Make Noise basis with the customer paying the transit cost to Make Noise. Please contact [technical@makenoisemusic.com](mailto:technical@makenoisemusic.com) for Return To Manufacturer Authorization.

Make Noise implies and accepts no responsibility for harm to person or apparatus caused through operation of this product.

Please contact [technical@makenoisemusic.com](mailto:technical@makenoisemusic.com) with any questions, needs & comments, otherwise... go MAKE NOISE!

<http://www.makenoisemusic.com>



### **About This Manual:**

Written by Tony Rolando

Edited by Walker Farrell

Illustrated by W.Lee Coleman

## Electrocution Hazard!

Always turn the Eurorack case off and unplug the power cord before plugging or un-plugging any Eurorack bus board connection cable.

Do not touch any electrical terminals when attaching any Eurorack bus board cable.

The Make Noise Pressure Points is an electronic music module requiring 20 mA of +12VDC and 0mA of -12VDC regulated voltage and a properly formatted distribution receptacle to operate. It must be properly installed into a Eurorack format modular synthesizer system case.

Go to <http://www.makenoisemusic.com/systems.shtml> for examples of Eurorack Systems and Cases.

To install, find 20HP in your Eurorack synthesizer case, confirm proper installation of included eurorack bus board connector cable on backside of module (see picture below), plug the bus board connector cable into the Eurorack style bus board, minding the polarity so that the RED stripe on the cable is oriented to the NEGATIVE 12 Volt line on both the module and the bus board. On the Make Noise 6U or 3U Busboard, the negative 12 Volt line is indicated by the white stripe.

**The Pressure Points module is not compatible with power solutions using the MeanWell brand AC Adapters. The Pressure Points module will not work on power solution using the MeanWell brand AC Adapters. Make Noise will not be able to provide support for Pressure Points modules used on power solutions using the MeanWell brand AC Adapters.**

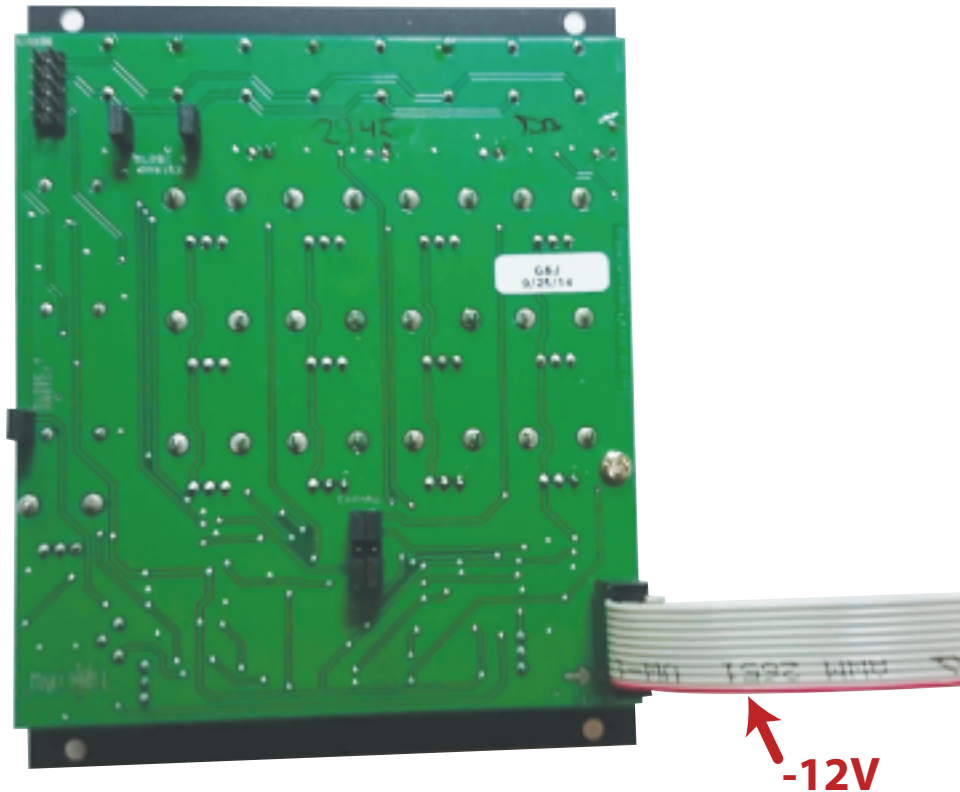

**Please refer to your case manufacturers' specifications for location of the negative supply.**

## Jumper and Cable Connections:

Note: Power connections for each module not shown for clarity

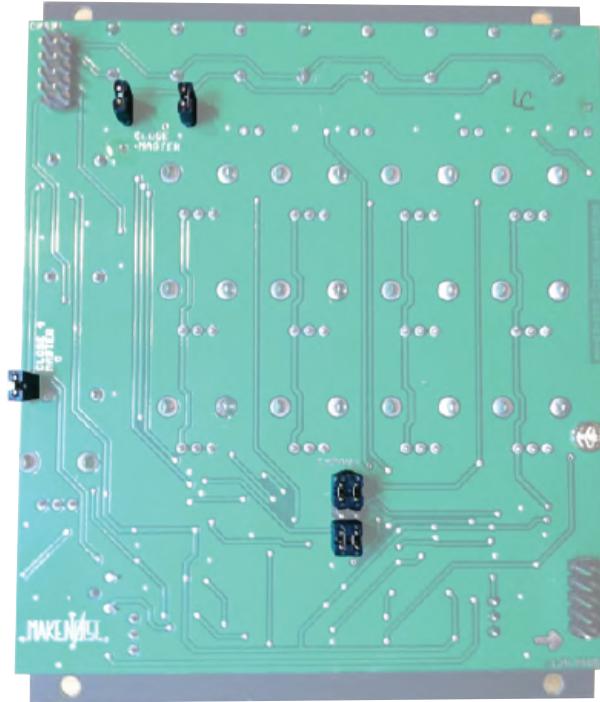

Single Pressure Points with no BRAINS attached. Note all the "Close 4 Master" locations are closed, as well as the Expand headers.

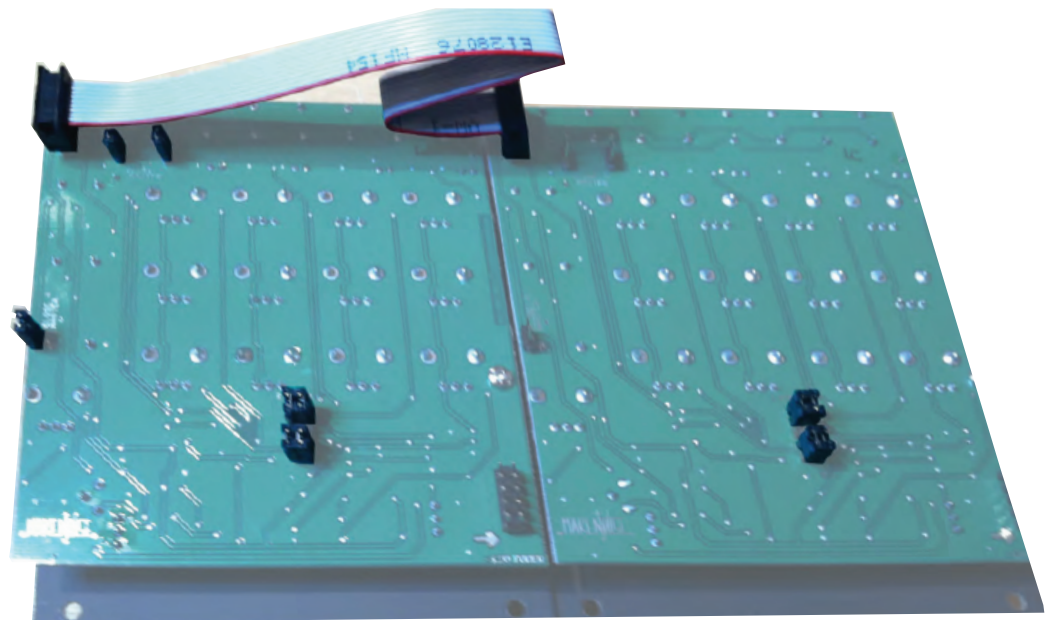

Two Pressure Points, chained. Note that the "Close 4 Master" headers are closed on the first unit (will be on the right when installed in the case). For three or four Pressure Points, use 4-header CHAIN cable and leave "Close 4 Master" headers open on all units but the master (rightmost when installed/leftmost from behind). Also, note the jumpers on the EXPAND headers.

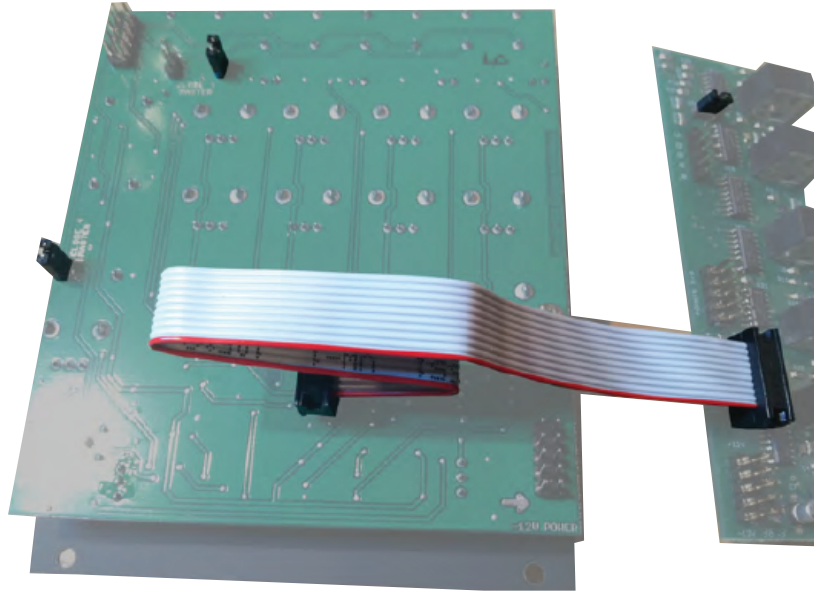

**BRAINS with a single Pressure Points:** Note the single open "Close 4 Master" header, the BRAINS cable connected from "Points 1-4" header to EXPAND header, and the jumper on BRAINS set to "1PP."

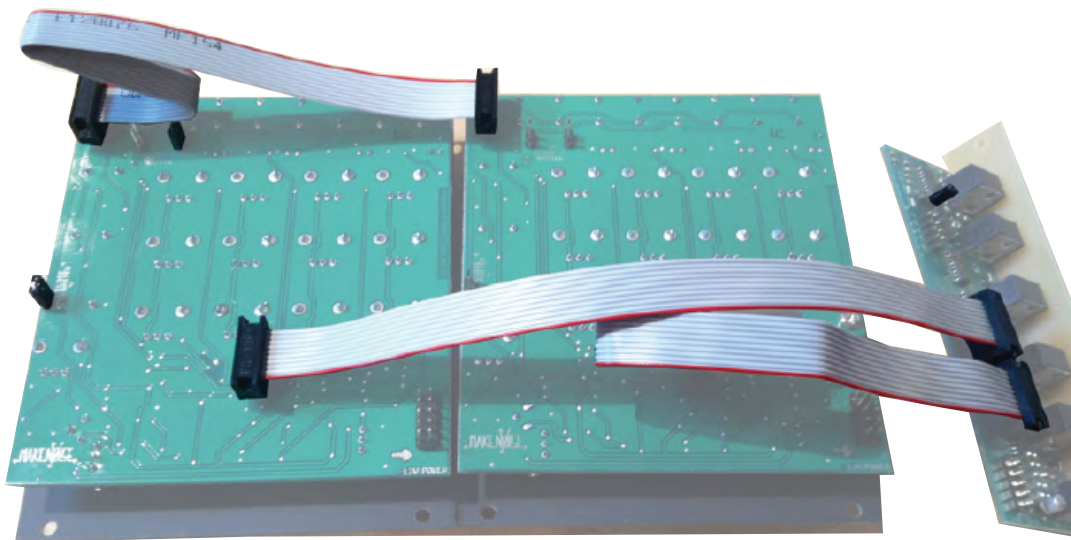

**BRAINS with two Pressure Points:** Two is the maximum number of Pressure Points that can be attached to a single BRAINS. Note: the connections of "Points 1-4" and "Points 5-8" to EXPAND headers the single open location on the "Master" Pressure Points' "Close 4 Master" headers; all three "Close 4 Master" locations open on the non-master Pressure Points, and the Jumper on BRAINS set to "2PP."

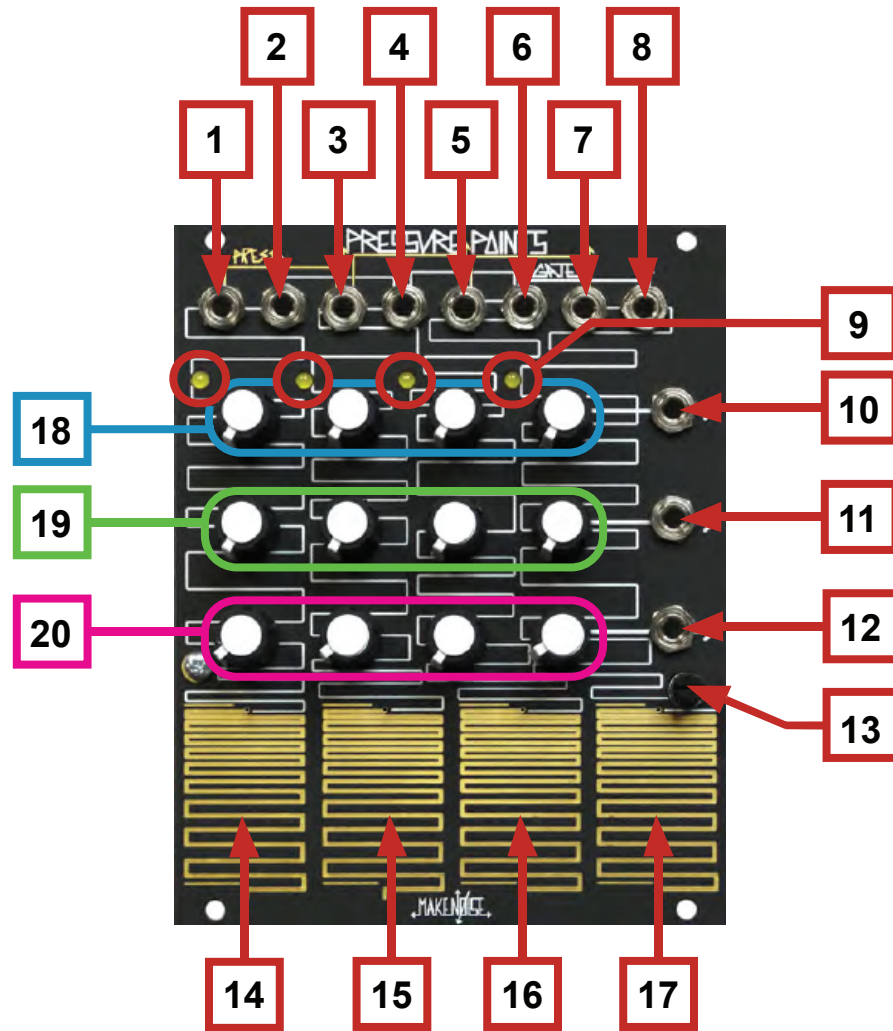

### Pressure Points Panel Connections

1. Channel 1 Pressure OUTPUT
2. Channel 1 Gate OUTPUT
3. Channel 2 Pressure OUTPUT
4. Channel 2 Gate OUTPUT
5. Channel 3 Pressure OUTPUT
6. Channel 3 Gate OUTPUT
7. Channel 4 Pressure OUT/ Combined Pressure OUTPUT
8. Channel 4 Gate OUT/ Combined Gate OUTPUT
9. Active Stage Indicator LEDs
10. Tuned Voltage Out X: 0 to 8V.
11. Tuned Voltage Out Y: 0 to 5.5V.
12. Tuned Voltage Out Z: 0 to 5.5V.
13. Digit Trimmer: Use to adjust Touch Plate sensitivity to taste.
14. Touch Plate 1: Press to Select Active Stage, Generate Gates, and Generate Pressures. Must be played with clean, bare hands.
15. Touch Plate 2: see above.
16. Touch Plate 3: see above.
17. Touch Plate 4: see above.
18. Tuned Voltage Potentiometers: Row X.
19. Tuned Voltage Potentiometers: Row Y.
20. Tuned Voltage Potentiometers: Row Z.



Pressure Points is a controller in which 1 of 4 sets of 3 tuned voltages are selected by touching the corresponding printed copper wire at the bottom of the instrument. Touching Pressure Points, you become part of the circuit, generating a gate signal (Gate OUT), a control signal proportional to the amount of pressure applied (Press OUT) and activating the corresponding Stage. The Tuned Voltages for the activated Stage appear at their respective X, Y and Z OUTs. In this way, Pressure Points is like an analog sequencer that is played by hand.

Stages can also be selected via clock inputs with the expander module, **BRAINS** (<http://www.makenoisemusic.com/brains.shtml>).

2 pots allow the circuit to be adjusted for desired playing response. Up to 4 of these modules may be CHAINED together to create controllers of varying size and complexity. The Gate and Press OUTs are normalized to their respective Combined BUS which is output at the last Gate or Press OUT in the CHAIN.

## Playing

The Pressure Points requires the development of a technique, and CLEAN, BARE Hands. Touching the upper-most portion of the touchplate with as little of your finger as needed to activate the circuit, will generate a Gate and select the corresponding Stage. The 3 Tuned Voltages, as set by the column of 3 Potentiometers above the touchplate, appear at their respective X, Y and Z OUTs. Laying more of your finger down on the touchplate, and pressing harder, will generate a pressure control voltage proportional to amount flesh mashed into the copper of the touchplate. Pressing harder, more of your flesh comes into contact with a sensitive point in the circuit, hence the name Pressure Points. Set the Touch Sensitivity Adjustment Potentiometer further CW so that you may slide effortlessly and quickly from stage to stage, or set it more CCW when you want greater control over the Press Control Signal. If you cannot obtain the desired response, you might need to adjust the internal Digit Trimmer to compensate for size & moisture of your digits as well as playing technique and style of installation (vertical, horizontal, angled). This requires a trimmer tool or jeweler's screwdriver, and access to the module from the right side, where the Digit Trimmer is located on the circuit board. Please turn the power for Pressure Points OFF while adjusting the trimmer. Default setting for Digit Trimmer is 40% CW. Setting more CW will increase sensitivity for smaller and/ or dryer fingers, or for Vertical installations. Due to the complex nature of the human finger, you will need to experiment with settings to achieve the best playing response.

## CHAINing Pressure Points:

Requires the 10 PIN CHAIN Cable, which is available where ever Pressure Points is sold, and the proper setting of jumpers on the modules to be CHAINED. Refer to the drawing on opposing page. All modules in the CHAIN will need to be connected to the power supply via their supplied power cables.

CARE for Pressure Points like you would most instruments, keeping it clean and avoiding the destruction of it's playing surface. Use a soft, dry cloth such as the 3M Microfiber Lens Cleaning Cloth.

- The Top row of Tuned Voltages range 0 to +8V, and may therefore be used to generate gate signals where full CW is Gate ON and full CCW is Gate OFF.
- Process the Pressure Control Signal with a slew limiter and attenuator on Channels 1 or 4 of MATHS to achieve larger than life modulations.
- Achieve a "Latched," "Toggled" or "Switching" control signal, use two stages of Pressure Points, where one has a Tuned Voltage set to 0V (toggled OFF), and the other has a Tuned Voltage set to the desired ON state (+8V, or Full CW, for example). Touch one stage to turn ON, and the other to turn OFF.
- Use for Preset Storage where you have 4 presets of 3 variables in a patch, variables being set by Tuned Voltages X, Y & Z. Additional variation is Preset by applying the independent Press and/ or Gate signals from each stage to different patch points. If the Gate is not need to initiate an event, apply to a patch point via an Attenuator & use as a touch controlled momentary modulation.
- All Tuned Voltage and Press CV outs will drive a passive 4-way mult with no loading.
- All Gate OUTs may be stacked to one Gate IN for Gate mixing.

## Patch Examples:

### Tactile Keyboard

Patch Tuned Output Row Y or Z to 1v/Oct input on VCO. Patch VCO output to LPG or VCA input. Patch Common Gate OUT to MATHS Ch1 or 4 input, or Gate input on ADSR envelope generator. Patch envelope out to control input on LPG/VCA. Tune knobs in voltage row to notes of your choice.

**Optional:** Skip envelope generator and/or VCA by patching Common Gate OUT directly to the Strike input on an Optomix, DPO or MMG.

**Optional:** Use common Pressure OUT or individual Pressure outs to control timbre, such as the cutoff frequency of a filter in series with the VCO, or the Fold input on a DPO.

### The New Bongo

Set up a VCO for two-operator FM by applying a SINE wave to its linear FM input, and patch it to the input of an Optomix. Patch Pressure Points Common Gate OUT to the Optomix Strike Input, and Gate OUT 3 to the DAMP input. Strike the "Bongo" with Touchplate 4 and "dampen" it during or after striking with touchplate 3. Use the DAMP input attenuator to set the amount of damping.

**Optional:** use one or more of the Pressure outputs to the Control and/or DAMP input on the Optomix for more fine control.

**Optional:** use Gate or Pressure Outs 1 and 2 to dampen or thin out the sound in other ways, such as shaping the DPO Final out from a Sine to a Spike, morphing the MODE on the MMG from low-pass to high-pass, or inverting the Gate Out with a channel of MATHS and sending it to the DPO's FOLD input to decrease harmonic content.