

HDI 1029

IR Audio Transmission Technology | Receivers

General Description

The HDI 1029 is a multi-channel stethoset receiver for narrow-band applications. It is very easy to use and comfortable to wear due to its light weight. It is powered by an environmentally friendly rechargeable accupack. The HDI 1029 is fitted with a squelch and energy-saving circuitry.



Technical Data

Modulation	narrow-band FM
Carrier frequencies	55 – 695 kHz
Channels (HDI 1029 PLL 16).....	ch. 0 – ch. 15, switchable
AF frequency response	50 – 8,000 Hz
THD (electrical)	typ. 2 %
AF signal-to-noise ratio	> 52 dB
Max. SPL	appx. 110 dB
Power supply.....	BA 90 accupack, 2.5 V, 170 mAh
Operating time	appx. 10 hrs
Weight	appx. 60 g (2.12 oz) including accupack

Features

- Multi-channel narrow-band receiver
- Extremely lightweight, only appx. 60 g including accupack
- Accupack can be recharged while remaining in the receiver
- Energy-saving circuitry
- Squelch
- Delivery includes: 1 x HDI 1029 multi-channel stethoset receiver
1 x BA 90 accupack

Recommended Accessories

- | | |
|--|--------------------------------|
| ■ BA 90 accupack | Cat. No. 003261 |
| ■ BA 90 charger for one | |
| L 90 European version | Cat. No. 003262 |
| L 90-120 USA version | Cat. No. 003396 |
| L 90/UK UK version | (available from Sennheiser UK) |
| ■ L 92-10 charging unit for 10 BA 90 | Cat. No. 003355 |
| ■ L 92-20 charging unit for 20 BA 90 | Cat. No. 003356 |
| ■ L 1030-10 charging unit for 10 receivers | Cat. No. 004024 |
| ■ L 29-50-2 charging case for 50 receivers | Cat. No. 004310 |
| ■ Plug-in mains unit for one L 92 or up to two L 1030 | |
| NT 92 European version | Cat. No. 003357 |
| NT 92-120 USA version | Cat. No. 003358 |
| NT 92-UK UK version | Cat. No. 003359 |
| ■ Plug-in mains unit for L 29-50-2 charging case or up to five L 1030-10 | |
| NT 2013 European version | Cat. No. 003433 |
| NT 2013-120 USA version | Cat. No. 003434 |
| NG 2013-UK UK version | Cat. No. 054332 |

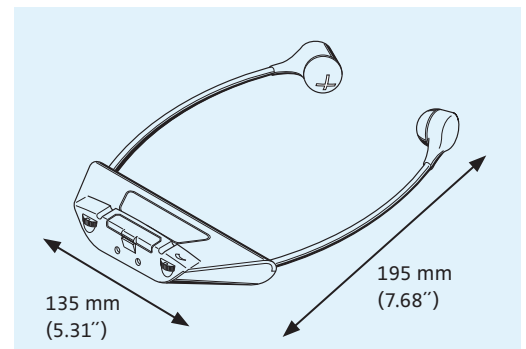

Dimensions of the HDI 1029

Product Variants

- HDI 1029 PLL 16: Multi-channel stethoset receiver, 16 switchable channels (ch. 0 – ch. 15) Cat. No. 003659
- HDI 1029 PLL 16 H: Multi-channel stethoset receiver, 16 switchable channels (ch. 16 – ch. 31) Cat. No. 004631
- HDI 1029 PLL 8: Multi-channel stethoset receiver, 8 switchable channels (ch. 0 – ch. 7) Cat. No. 003676

HDI 1029

IR Audio Transmission Technology | Receivers

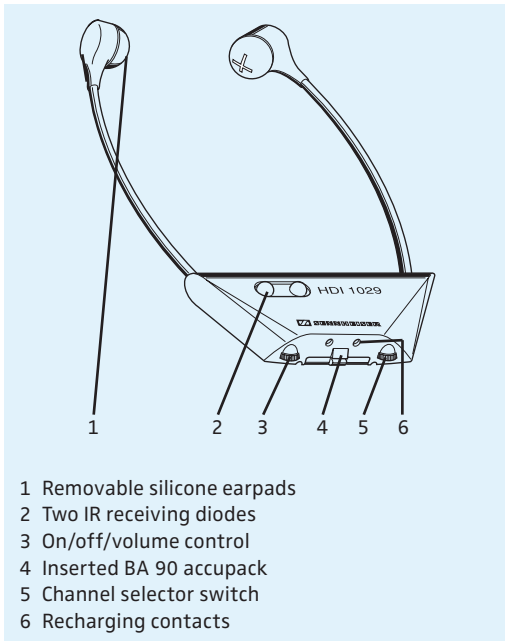

- 1 Removable silicone earpads
- 2 Two IR receiving diodes
- 3 On/off/volume control
- 4 Inserted BA 90 accupack
- 5 Channel selector switch
- 6 Recharging contacts

Controls of the HDI 1029

The HDI 1029 is a multi-channel narrow-band stethoset receiver. Depending on the model, it can be switched between 8 or 16 channels. Due to this multi-channel design, it is ideally suitable for use at international conferences. The stethoset receiver is an economical alternative to the bodypack receiver with its "external" headphone. Short events with a changing audience bring out the special advantages of this type of receiver: they can be quickly distributed and collected again as there is no cable to get entangled.

The transducers of the HDI 1029 are situated directly behind the ear pads. The resulting sound quality is clearly better than that of systems using pneumatic transmission. Moreover, the stethoset design clearly attenuates ambient noise, values of up to 15 dB having been achieved. This attenuation for example increases the intelligibility of translations when the floor language is being reinforced at the same time. The operating controls of the HDI 1029 – a combined on/off/volume control and a channel selector switch – are located at the bottom of the receiver where they are protected against coffee splashes etc. After use, the receiver should always be switched off. The IR receiving diodes are located on the front of the receiver. Thus, the users always have good reception as long as the diodes do not face the body.

The HDI 1029 has a built-in squelch. When the IR signal from the radiators becomes too weak, the receiver mutes the audio output in order to avoid loud hiss. During conference breaks, this muting circuit serves to save energy. The receiver switches to stand-by so that the BA 90 accupack is not discharged too quickly. The environmentally friendly BA 90 has a weight of only 8 g and allows an operating time of approx. 10 hrs with the HDI 1029. The various possibilities for recharging the BA 90 are described below.

The silicone earpads of the HDI 1029 can easily be removed and cleaned. Nevertheless, they are tightly attached to the headphones to prevent them slipping off accidentally.

The smallest available charger for the BA 90 is the L 90 which has been designed for one accupack. If you want to recharge several BA 90 at the same time, you should use the L 92 charging unit for up to ten or up to twenty accupacks. The BA 90 are inserted into the units from both sides, and recharging is indicated by the LEDs on top of the charging unit.

However, the best solution is to recharge the accupacks while they remain inserted in the receivers. The L 1030-10 charging unit can recharge up to ten complete receivers. It is powered by the plug-in mains unit NT 92, which is suitable for up to two L 1030-10. For up to five cascaded units, you can use the NT 2013 or NG 2013-UK. The necessary plug-in mains units are not delivered with the charging units. Please order them separately in the version you require (European, UK and USA versions available).

The L 29-50-2 charging and transport case makes storing and recharging still easier. The charging case can accommodate up to 50 HDI 1029, the accupacks remain in the receivers and recharging is timer-controlled. Power is supplied via an NT 2013 (or NG 2013-UK) plug-in mains unit which must be ordered separately. The BA 90 accupacks cannot be overcharged, so they can remain in the charging units even when they have been fully recharged, which takes approximately 14 hrs. The charging unit in the L 29-50-2 automatically switches over to trickle charging after 14 hours.

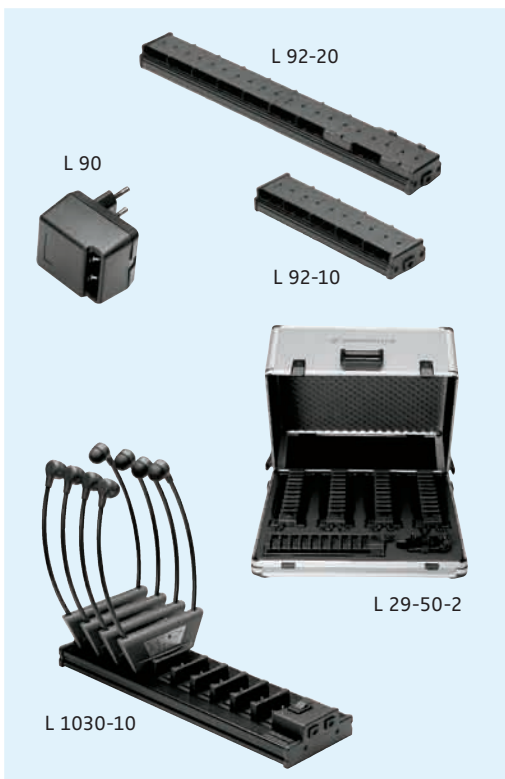

Options for recharging the BA 90