



Product Reference Sheet

SPX Ellipsoidal

ELLIPSOIDALS FOR THE 21ST CENTURY

A precision lighting instrument delivering the highest efficiency in ERS luminaires combined with the performance excellence, and user-friendly operational and safety features you expect from Philips Selecon.

Up to 27% more efficient than current industry benchmark units.

Fully adjustable beam distribution from flat to true peak field.

SEVEN optical systems: 15°-35° and 25°-50° Zoomspots; 14°, 19°, 26°, 36° and 50° Fixed Beams.

ALL lens tubes interchangeable and can be ordered separately.

Features

Designed to manage the power and heat from high output tungsten halogen 800W sources.

More light and high contrast pattern projections - fully adjustable beam distribution from peak (3:1) to flat (2:1) using intuitive adjustment solution.

Precise positioning with rigid monocoque moulded yoke, shutter clamp lock, and reference scales on tilt, lens and lens tube angle settings.

Compartmental heat management system exhausts the heat away from the critical lamp socket and cabling to minimise heat damage.

Minimal light spill with enclosed front colour frame / accessory holder.

Dual accessory slots for simultaneous use of 'B' size gate patterns, rotators and irises.

360° barrel rotation.

Mains isolation via micro-switch for maximum safety while re-lamping.

Fitted safety bond.

Ease of maintenance – full access to all lens surfaces for cleaning.

Three-year warranty.

Approvals

Fully compliant to CE standards.

Lamps 220V-240V

600W GKV 400hrs average life

600W GLB 1500 hours average life

800W GKV 300hrs average life

Order codes

Complete Luminaire

SPX1535 SPX 15°-35° Zoomspot

SPX 2550 SPX 25 -50° Zoomspot

SPX 14 SPX 14° Fixed Beam

SPX 19 SPX 19° Fixed Beam

SPX 26 SPX 26° Fixed Beam

SPX 36 SPX 36° Fixed Beam

SPX 50 SPX 50° Fixed Beam

Accessories

20IRIS SPX 20-leaf Iris

SPXGHB SPX 'B' Pattern Holder

SPXGHGB SPX 'B' Pattern Holder – glass

19PACSMFB SPX Lens Safety Mesh

19PACCF SPX Colour Frame

20HC SPX Suspension Hook Clamp



Photometric data

ZOOMSPOTS:

Zoom 15° - 35°		Beam Diameter (meters)				
	15°	0	1.6	2.6	3.9	5.3
Throw Distance (meters)		0	6	10	15	20
Central illumination (Lux)						
Philips	15°	Peak	9571	3445	1531	861
		Flat	4858	1749	777	437

Zoom 15° - 35°		Beam Diameter (meters)				
	35°	0	3.2	5.0	7.6	9.5
Throw Distance (meters)		0	5	8	12	15
Central illumination (Lux)						
Philips	35°	Peak	5032	1966	874	559
		Flat	2555	998	444	284

Zoom 25° - 50° at 25°		Beam Diameter (meters)				
	25°	0	1.3	2.7	4.4	6.7
Throw Distance (meters)		0	3	6	10	15
Central illumination (Lux)						
Philips	25°	Peak	19075	4769	1717	763
		Flat	11498	2875	1035	460

Zoom 25° - 50° at 50°		Beam Diameter (meters)				
	50°	0	2.8	5.6	9.3	11.2
Throw Distance (meters)		0	3	6	10	12
Central illumination (Lux)						
Philips	50°	Peak	7336	1834	660	459
		Flat	2951	738	266	184



FIXED BEAMS

Fixed 14°		Beam Diameter (meters)					
		14°	0	2.5	3.7	6.1	7.4
Throw Distance (meters)		0	10	15	25	30	
		Central illumination (Lux)					
Phlips	14°	Peak	4019	1786	643	447	
		Flat	2845	1264	455	316	

Fixed 19°		Beam Diameter (meters)					
		19°	0	2.7	4.0	6.0	8.4
Throw Distance (meters)		0	8	12	18	25	
		Central illumination (Lux)					
Phlips	19°	Peak	5365	2384	1060	549	
		Flat	4254	1891	840	436	

Fixed 26°		Beam Diameter (meters)					
		26°	0	2.3	4.6	6.9	9.2
Throw Distance (meters)		0	5	10	15	20	
		Central illumination (Lux)					
Phlips	26°	Peak	6715	1679	746	420	
		Flat	5425	1356	603	339	

Fixed 36°		Beam Diameter (meters)					
		36°	0	3.2	5.2	7.8	9.7
Throw Distance (meters)		0	5	8	12	15	
		Central illumination (Lux)					
Phlips	36°	Peak	3755	1467	652	417	
		Flat	2430	949	422	270	

Fixed 50°		Beam Diameter (meters)					
		50°	0	2.8	4.7	7.5	9.3
Throw Distance (meters)		0	3	5	8	10	
		Central illumination (Lux)					
Phlips	50°	Peak	5792	2085	815	521	
		Flat	3633	1308	511	327	



G9.5 Lamp	Manu. Code	Voltage	Wattage	ANSI	Life to 50% Failure [nom]	Lamp Luminous Flux [lm] [nom]	15-35° ZOOM		25-50° ZOOM		FIXED BEAM						
							at 15°	at 35°	at 25°	at 50°	14°	19°	26°	36°	50°		
	Philips 6982P	240	800	GKV	200	20,000	1.00	1.00	1.00	1.00	1.00	1.00	1.00	1.00	1.00	1.00	1.00
	Philips 6986P	240	600	GKV	300	15,000	0.77	0.76	0.77	0.71	0.81	0.78	0.80	0.77	0.78		
	<i>Philips 6991P</i>	<i>240</i>	<i>600</i>	<i>GLB</i>	<i>1500</i>	<i>13,000</i>	<i>0.67</i>	<i>0.66</i>	<i>0.66</i>	<i>0.62</i>	<i>0.70</i>	<i>0.68</i>	<i>0.69</i>	<i>0.67</i>	<i>0.68</i>		
	Philips 6982P	230	800	GKV	200	20,000	1.00	1.00	1.00	1.00	1.00	1.00	1.00	1.00	1.00	1.00	1.00
	<i>Philips 6986P</i>	<i>230</i>	<i>600</i>	<i>GKV</i>	<i>300</i>	<i>14,700</i>	<i>0.75</i>	<i>0.75</i>	<i>0.75</i>	<i>0.70</i>	<i>0.79</i>	<i>0.76</i>	<i>0.78</i>	<i>0.75</i>	<i>0.76</i>		
	<i>Philips 6991P</i>	<i>230</i>	<i>600</i>	<i>GLB</i>	<i>1500</i>	<i>13,000</i>	<i>0.67</i>	<i>0.66</i>	<i>0.66</i>	<i>0.62</i>	<i>0.70</i>	<i>0.68</i>	<i>0.69</i>	<i>0.67</i>	<i>0.68</i>		
	Philips 6981P	115	750	-	300	20,500	1.10	1.09	1.06	1.11	1.28	1.05	1.18	1.15	1.16		
	Philips 6989P	115	575	GLC	400	15,500	0.97	0.91	0.88	0.90	1.09	0.88	0.99	0.91	0.92		
	<i>Philips 6992P</i>	<i>115</i>	<i>575</i>	<i>GLA</i>	<i>1500</i>	<i>13,500</i>	<i>0.84</i>	<i>0.80</i>	<i>0.77</i>	<i>0.78</i>	<i>0.95</i>	<i>0.77</i>	<i>0.86</i>	<i>0.79</i>	<i>0.80</i>		
	<i>Osram HP GLG</i>	<i>115</i>	<i>375</i>	<i>GLG</i>	<i>300</i>	<i>10,000</i>	<i>0.62</i>	<i>0.59</i>	<i>0.57</i>	<i>0.58</i>	<i>0.70</i>	<i>0.57</i>	<i>0.64</i>	<i>0.59</i>	<i>0.59</i>		

Note:
Photometric Tests conducted under laboratory conditions with calibrated lamps at the rated voltage, data then normalised to nominal Lamp Luminous Flux
Figures in Red Italics extrapolated from test data

Physical data

Pattern (Gobo) size: B

Luminaire supplied with: 1x 158mm² colour frame, 1x fitted safety bond, 1x M12 nut & bolt set, instruction leaflet.

Size Diagrams and Weights

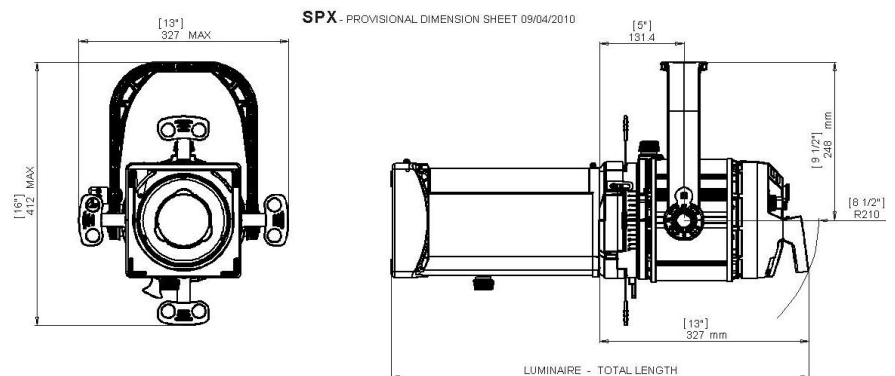

	Lens Angle	Lens Tube Length		Luminaire Total Length		Approx. Weight for Complete Luminaire	
		metric (mm)	imperial (")	metric (mm)	imperial (")	metric (kg)	imperial (lbs)
Fixed	14	400	15.7	700	27.6	8.3	18.25
	19	310	12.2	610	24.0	8.3	18.25
	26	270	10.6	570	22.4	8.3	18.25
	36	250	9.8	550	21.7	8.3	18.25
	50	200	7.9	500	19.7	8.3	18.25
Zoom	15-35	370	14.6	670	26.4	8.3	18.25
	25-50	280	11.0	580	22.8	8.3	18.25

Philips Selecon

19-21 Kawana Street, Northcote
Auckland 0627, New Zealand
Tel: +64 9 481 0100 Fax: +64 9 481 0101

Philips Selecon Australia

PO Box 5925
Westend, QLD 4101, Australia
Tel: +61 419 133 342

Strand Lighting Asia Limited

Room 6-10,
20/F Delta House 3 On Yiu Street
Shatin, N.T. Hong Kong
Tel: +852 2757 3033 Fax: +852 2757 1767

Philips Entertainment Europe

Marssteden 152
Enschede 7547 TD
The Netherlands
Tel: +31 53 450 0424 Fax: +31 53 450 0425

© Philips Group 2010

All rights reserved.

The Company reserves the right to make any variation in design or construction to the equipment described. E&OE

PHILIPS
Entertainment