

ND1070

Key Features

- 109 dB SPL 1W / 1m average sensitivity
- 1 inch exit throat
- 44 mm (1 3/4 inch) edgewound aluminum voice coil
- 100 Watt program power handling
- Titanium dome over polyester suspension
- Proprietary phase plug design
- Neodymium magnetic structure
- Excellent thermal exchange

General Description

The ND1070 1-inch exit high frequency compression driver has been designed for use in high quality two-way audio systems.

Equipped with Proprietary Phase Plug architecture, ND1070 shows high level manufacturing consistency and a smooth coherent wavefront at the horn entrance across the whole working frequency range. With its short openings and high flare rate value, this phase plug configuration assures low distortion and demonstrates remarkable improvements in mid-high frequency reproduction.

The ND1070 diaphragm assembly is composed of a titanium dome sandwiched to a proprietary treated polyester suspension. This design maintains low resonance and lowers the minimum crossover point value to 1.6 kHz.

An edge-wound aluminum voice coil wound on proprietary treated Nomex completes the diaphragm assembly. Nomex shows a 30% higher value of tensile elongation at a working operative temperature (200°C) when compared to Kapton. This feature enables proper energy transfer control from the voice coil to the dome in real working conditions. Moreover, this proprietary former material is also suitable for use in high moisture content environments.

A copper ring on the pole piece reduces inductance above 10 kHz, improving phase and impedance linearization.

By careful use of elementary pieces of neodymium magnets, Eighteen Sound engineers have developed a powerful neodymium magnet assembly capable of reaching 18KGauss in the gap within a compact and lightweight structure.

The custom designed O-ring creates a tight seal between the plate and the cover assuring air chamber loading.

Excellent heat dissipation and thermal exchange are guaranteed by the direct contact between the magnetic structure and the aluminum cover which leads to a lower power compression value.

The ability to perform properly under inclement weather conditions is a key feature in Eighteen Sound philosophy. A special treatment has been applied to the magnet and the top and back plates of the magnetic structure making the driver more resistant to the corrosive effects of salts and oxidization. This treatment is more effective than any other treatment used by other manufacturers.

Neo High Frequency Driver



0421T8M400 8 Ohm
0421T6M400 16 Ohm

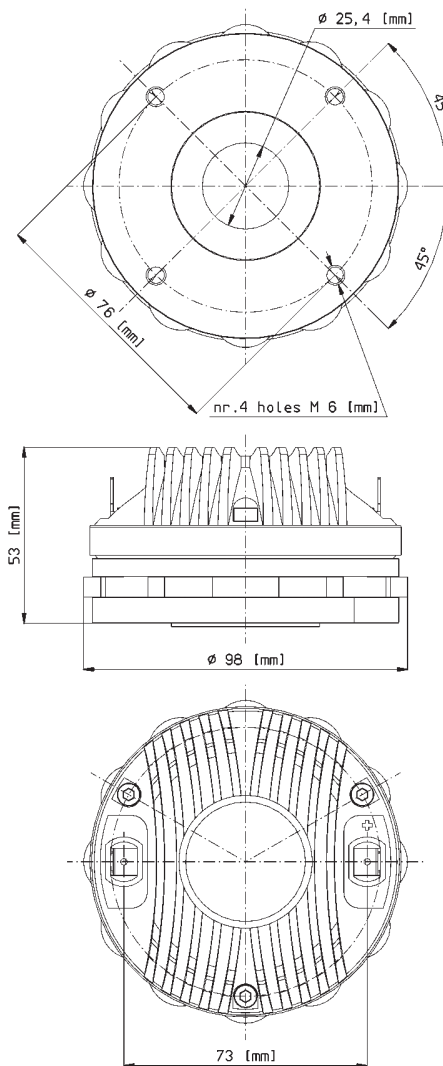

NEODYMIUM HF DRIVERS

ND1070

Neo High Frequency Driver

GENERAL SPECIFICATIONS

THROAT DIAMETER	25,4 mm (1 in)
RATED IMPEDANCE	8 ohm
DC RESISTANCE	5,3 Ohm
MINIMUM IMPEDANCE	7 Ohm at 4000Hz
LE (AT 1KHZ)	67 µH
AES POWER (1)	50 W above 1,6 kHz
PROGRAM POWER (2)	100 W above 1,6 kHz
SENSITIVITY(1W@1M) (3)	109 dB
FREQUENCY RANGE	1600Hz ÷ 20kHz
RECOMM. XOVER FREQUENCY	1600Hz (12dB/oct slope)
DIAPHRAGM MATERIAL	Titanium - Polyethylene
VOICE COIL DIAMETER	44,4 mm (1 3/4 in)
VOICE COIL WINDING MATERIAL	Edge-wound aluminum
MAGNET MATERIAL	Neodymium
FLUX DENSITY	1,8 T
BL FACTOR	8,2 N/A
POLARITY	Positive voltage on "+" terminal gives positive pressure in the throat

MOUNTING INFORMATION

Overall diameter	98 mm (3,9 in)
Mounting holes diameter	4 M6 holes 90° at Ø 76 mm (3 in)
Bolt circle diameter	76 mm (3 in)
Total depth	53 mm (2,1 in)
Net weight	1,1 Kg (2,4 lb)
Shipping weight	1,2 Kg (2,6 lb)
CardBoard Packaging dimensions	97x97x58 mm (3,8x3,8x2,3 in)

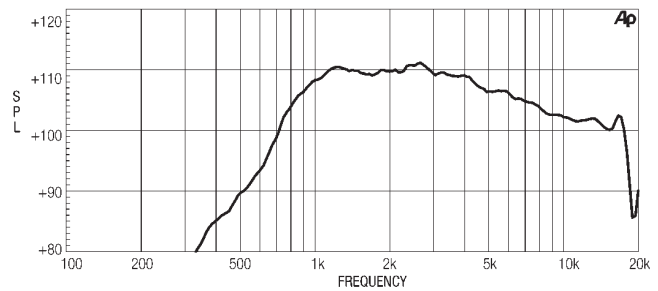
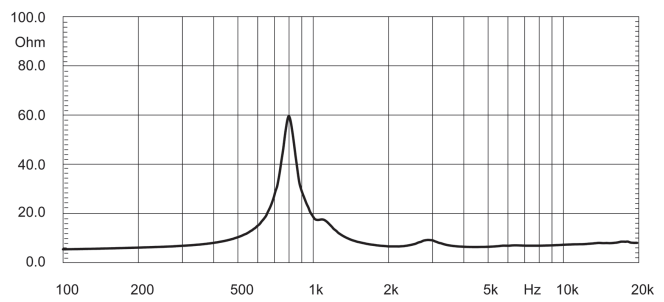
ND1070 MEASURED WITH 1W INPUT ON RATED IMPEDANCE AT 1M DISTANCE ON XT1086 HORN MOUTH AXIS**FREE AIR IMPEDANCE MAGNITUDE CURVE****NOTES**

- (1) AES power rating is tested with a pink noise input having a 6 dB crest factor for two hours duration within the specified range. Power calculated on minimum impedance.
- (2) Program power rating is defined as 3 dB greater than AES rating, and is a conservative expression of the transducer ability to handle music program material.
- (3) Sensitivity is measured at 1W input on rated impedance at 1m on axis from the mouth of XT1086 horn, averaged between 1kHz and 4 kHz.

Eighteen Sound engages in research and product improvement. New materials and design refinements can be introduced into existing products without notice.