

- ✓ For USB 2.0 full speed
- ✓ Supports 24 bit / 96 kHz sampling rate
- ✓ Low cut / sensitivity / mute switch
- ✓ Mic gain control / monitoring volume control
- ✓ Compatible with Win XP, Win 2000, Win 7~10, MAC OS

Caution!

- ▶ Never remove the screen holding the capsule, as this may damage the microphone!
- ▶ Never drop the mic, as this may cause severe damage!
- ▶ When the microphone is not in use, take it out of its clamp and put it in its case. Clean with damp cloth only.

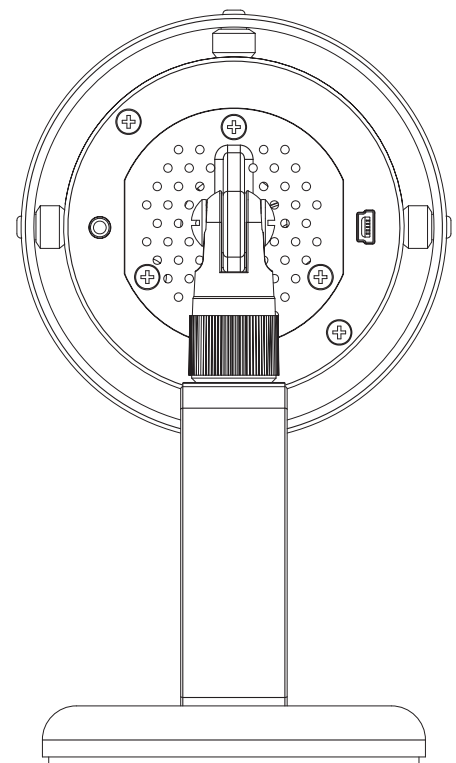
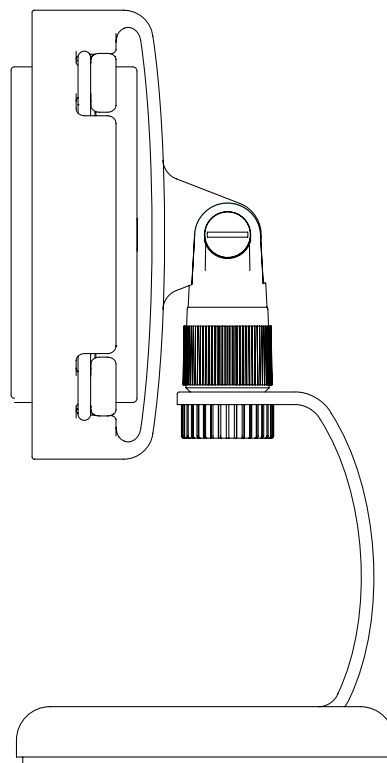

Connection / Supply	USB
Transducer concept	Back electret condenser
Directivity	cardioid
Diaphragm thickness	2 μ m
Digital sensitivity	min. -40 dBFS / Pa max. -4 dBFS / Pa
SPL	130 dB
S/N ratio	> -90 dB
Low cut	< 80 Hz / -10 dB
Frequency response	20 – 18.000 Hz
Weight	400 g

For the transport and protective packaging, environmentally friendly materials have been chosen that can be supplied to normal recycling. Ensure that plastic bags, packaging, etc. are properly disposed of. Do not just dispose of these materials with your normal household waste, but make sure that they are collected for recycling. Please follow the notes and markings on the packaging.

This product is subject to the European Waste Electrical and Electronic Equipment Directive (WEEE) in its currently valid version. Do not dispose of your old device with your normal household waste. Dispose of this product through an approved waste disposal firm or through your local waste facility. Comply with the rules and regulations that apply in your country. If in doubt, consult your local waste disposal facility.