

HALF COUPLER SMALL BUSBAR 48-51 | 30 | 100KG

CODE 888813



Dieser Coupler wurde speziell für den Messe- und Ladenbau entwickelt. Er dient zur Befestigung von 3-Phasen Stromschielen an Traversen.

This coupler was specially developed for trade fair and retail constructions. It can be used to attach 3-phase power rails to trusses.

Kompatibel compatible	48-51 mm
Breite width	30 mm
Zugbelastung tensile load	100 kg
Abgang retaining screw	für 3-Phasen Stromschiene 3 phase busbar
Verschluss screw plug	M8 Flügelmutter wing nut
TÜV geprüft TÜV approved	Ja yes
Belastung load	50 kg (BGV C1)
Bruchkraft tensile strength	4,9 kN
Aluminium aluminum	6061 T6
Geprüft nach tested according	DIN 4113-1:1980 + A1: 2002 DIN 41136-2:2002, DIN V 4113-3:1999

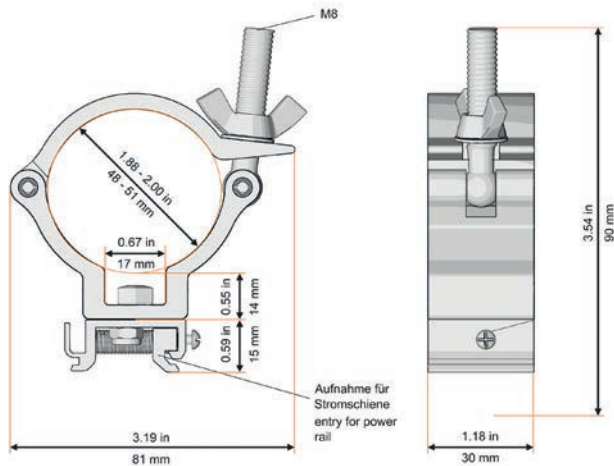

KOMPATIBILITÄT | COMPATIBILITY

