

BST-01 Double Bass Stand

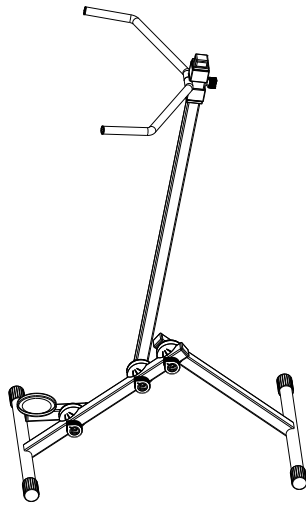

- Stable stand for all sizes of double basses
- Height-adjustable bracket to hold the middle bout
- Adjustable endpin holder
- Foldable
- Maximum feet width: 40 cm
- Maximum bracket height: 83 cm
- Maximum bracket width: 44.8 cm (inside)
48 cm (outside)
- Weight: 2.7 kg
- Colour: black

Not suitable for permanent use for double basses with nitrocellulose lacquer!

Mounting

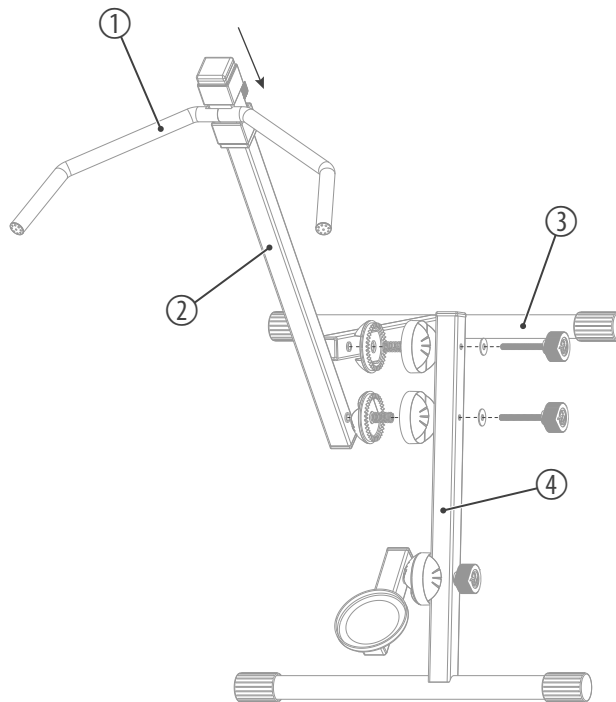

Intended use

This device is intended for use as holder for double basses. Any other use is considered to be improper and may result in personal injury or property damage. No liability will be assumed for damages resulting from improper use.



Danger for children

Ensure that plastic bags, packaging, etc. are disposed of properly and are not within reach of babies and young children. Choking hazard! Ensure that children do not detach any small parts from the product. They could swallow the pieces and choke! Never let children unattended use the product.

Danger of tipping on unsuitable ground

If placed on soft or uneven ground, the stand may overturn and cause injuries and property damage. Place the stand on flat and solid surfaces only.

Danger of tipping during loaded transport

If the stand is moved without removing the loaded equipment, the stand may tip over and cause injuries and property damage. Remove all equipment from the stand before moving the stand.



Possible staining

The plasticiser contained in the rubber feet of this product may possibly react with the coating of your surface and after some time cause permanent dark stains. In case of doubt, do not put the rubber feet directly on the surface and use a suitable underlay if necessary, i.e. felt-pad floor protectors or similar.

We tested the stand with different guitars and finishes and no problems were encountered. Nevertheless, we advise caution with vintage instruments and nitrocellulose finishes. Sweat, environmental influences, nitrocellulose and age can cause chemical reactions that cannot be predicted or tested. We therefore do not accept any guarantee for damage to surfaces caused by such circumstances.



For the transport and protective packaging, environmentally friendly materials have been chosen that can be supplied to normal recycling. Ensure that plastic bags, packaging, etc. are properly disposed of. Do not just dispose of these materials with your normal household waste, but make sure that they are collected for recycling. Please follow the notes and markings on the packaging.