

## Monitor Speaker Stand Clamp

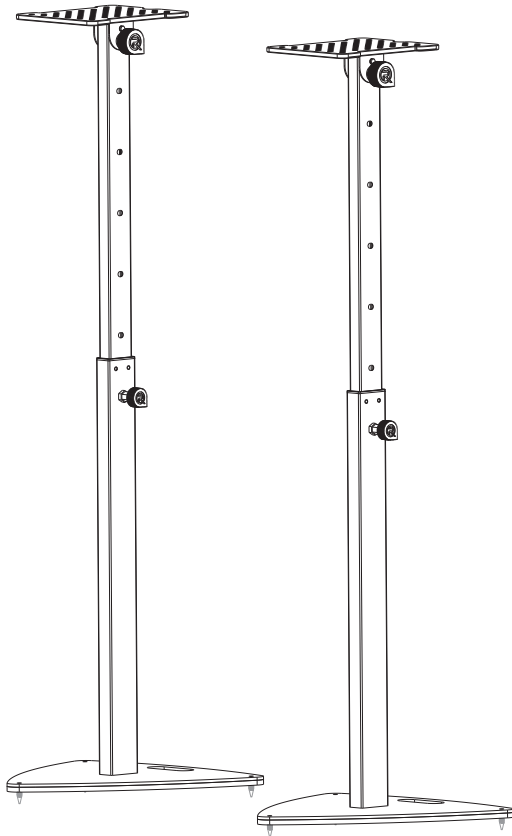

- Stand set for monitor speaker
- Rubberised support surface for a stable position with 360-degree rotation
- Foot with non-slip foam rubber
- Locking pin prevents unexpected lowering of the extension tube
- Angle of inclination  $\pm 10^\circ$  adjustable
- Height adjustable in 6 levels: 760 mm - 1,255 mm
- Support surface (W  $\times$  D): 185 mm  $\times$  225 mm
- Base plate (W  $\times$  D): 430 mm  $\times$  403 mm
- Material: Steel
- Colour: Black
- Max. load capacity: 35 kg
- Weight per piece: 7.25 kg
- Scope of delivery: 2 pieces
- Accessories: 2  $\times$  Allen key, 3  $\times$  spikes for optional use

### Assembly

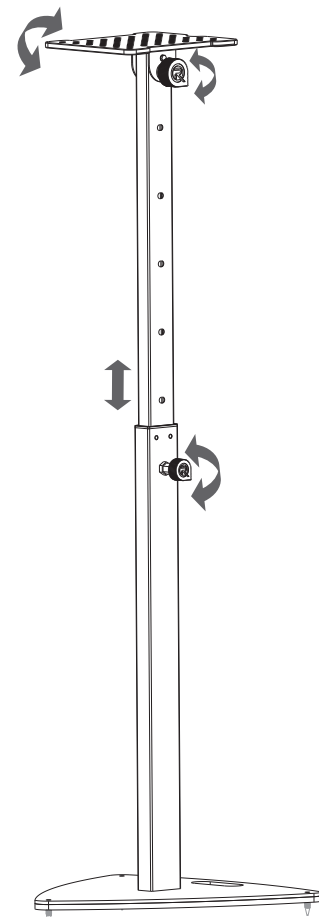

**General information**

This document contains important information. Read and follow the instructions. Keep the document for future reference. If you pass the product on to others, please include this document.

Contents are subject to change. Please refer to the latest version of the documentation, which is available for download at [www.thomann.de](http://www.thomann.de).

**Intended use**

This product is designed for the height-adjustable installation and alignment of speakers. Any other use or use under other operating conditions is considered to be improper and may result in personal injury or property damage. No liability will be assumed for damage resulting from improper use. This product may be used only by persons with sufficient physical, sensory, and intellectual abilities and with the relevant knowledge and experience. Other persons may use this device only if they are supervised or instructed by a person who is responsible for their safety.

**Risk of injury and choking hazard for children!**

Children can suffocate on packaging material and small parts. Children can injure themselves when handling the product. Never allow children to play with the packaging material and the product. Always store packaging material out of the reach of babies and small children. Always dispose of packaging material properly when it is not in use. Never allow children to use the product without supervision. Keep small parts away from children and make sure that the product does not shed any small parts that children could play with.

**Risk of injury from falling devices!**

If the support surface of the product is tilted, the device resting on it can fall down and cause injuries and property damage. Do not tilt the support surface if the positioned device does not have a firm hold.

**Risk of injury due to the product tipping over from excessive loading!**

In case of excessive loading, the product can tip over and cause injury and property damage. Never exceed the specified maximum load for the product.

**Risk of injury due to tipping of the product on unsuitable ground!**

If the product is set up on soft or uneven ground, the product can tip over and cause injuries and property damage. Always set up the product on firm and level ground.

**Risk of injury due to tipping of the product during transport under load!**

If the product is moved without removing the devices placed on it, the product may tip over and cause injuries and property damage. Always remove any devices placed on the product before transporting the product.

**Risk of cuts to the hands from sharp edges during assembly!**

Tools, screws and components can have sharp edges that can cause cuts during assembly. Pay attention to sharp edges when assembling and screwing the individual parts. Wear protective gloves if necessary.

**Possible staining due to plasticiser in rubber pads!**

The plasticiser in the rubber pads of this product may react with other materials, resulting in permanent staining after a while. The product is not suitable for continuous use.

**Disposal of the packing material**

Environmentally friendly materials have been chosen for the packaging. These materials can be sent for normal recycling. Ensure that plastic bags, packaging, etc. are disposed of in the proper manner. Do not dispose of these materials with your normal household waste, but make sure that they are collected for recycling. Please follow the instructions and markings on the packaging.

**Disposal of your old product**

Do not dispose of your old product with your normal household waste; instead, deliver it for controlled disposal by an approved waste disposal firm or through your local waste facility.

Proper disposal protects the environment as well as the health of your fellow human beings. This is because the proper handling of old products negates the potential negative effects of hazardous substances, and because it conserves resources by recycling them.

Also note that waste avoidance is a valuable contribution to environmental protection. Repairing a device or passing it on to another user is an ecologically valuable alternative to disposal. For example, use the Thomann GmbH classified ads.



Observe the disposal note regarding documentation in France.