

SMART HOOK 48-51 | 50 | 100KG

CODE 5075-1 / 5075-1B



Einfacher Haken zum Einhängen an die Traverse mit einem Verschluss, der von unten greift.

Simple hook for hanging devices on the truss with a lock which grips from underneath/below.

Kompatibel | compatible
 Breite | width
 Zugbelastung | tensile load
 Abgang | retaining screw

48-51 mm
 50 mm
 100 kg
 M10 Flügelmutter,
 Sprengring, Unterlagsscheibe
 M10 screw, spring-lock, washer

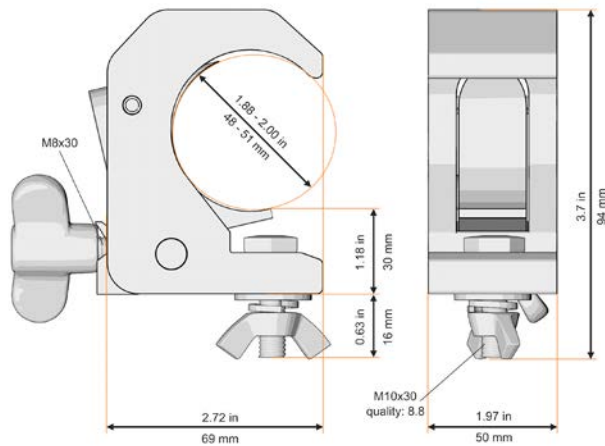

KOMPATIBILITÄT | COMPATIBILITY



F52 Folding



F54



F44



F44P



F34



F34P



F34PL



F34QX



F24



F43



F33



F33PL



M25AS



F23



F42



F32



F22



F31



F31PL