

StageSource L2t

Compact, 2-Way All-in-One PA with Studio-Quality Sound



Technical Specifications



StageSource® L2t Technical Specifications

StageSource L2t combines multi-function design, powerful DSP and precision components to deliver the perfect blend of performance and scalability in a portable package for musicians on the go. With speaker performance modes, an integrated mixer and digital networking, StageSource L2t delivers best-of-class performance across the widest variety of live sound applications.

- DSP-powered speaker performance modes for great live sound in any application
- Multi-channel mixer with 3-band EQ, Smart Effects and acoustic guitar modeling
- Multi-function design for true scalability
- L6 LINK™ digital networking for multi-speaker setups
- 800-watt, 2-way, bi-amped speaker system
- Multi-band feedback suppression
- On-board accelerometer and pole-mount sensors
- Virtual Tilt-back projects speaker's output upwards in backline mode
- Tour-grade plywood enclosure with M10 suspension points
- Retractable handle for easy portability

Acoustical

System Type:	10", 2-way, bi-amplified loudspeaker system
Frequency Range (-10dB):	44Hz to 19kHz, (Reference/P.A. Speaker Mode, free-field)
Frequency Response (±3dB):	51Hz to 18kHz, (Reference/P.A. Speaker Mode, free-field)
Maximum SPL Output:	128dB peak @ 1 meter (unweighted, measured indoors with music program material)
Coverage Pattern (-6dB):	100° horizontal x 50° vertical
Directivity Factor (Q):	9.2 (averaged 1kHz to 16kHz)
Directivity Index (DI):	9.6dB (averaged 1kHz to 16kHz)
Crossover Frequencies:	LF to HF Crossover - variable, 2.2kHz to 7.0kHz (Speaker Mode dependent)
Low Frequency Transducer:	10" extended range woofer, 2" diameter voice coil, 4Ω impedance
High Frequency Transducer:	1" exit compression driver, 1.4" diameter voice coil and diaphragm, 8Ω impedance

Electrical – Side Panel

Input Type:	2x mic/instrument XLR-1/4", balanced
Input Impedance (each input):	2.63 kΩ balanced (Pad = 0dB), 23.7 kΩ balanced (Pad = 20dB)
Gain Range (each input):	-infinity to +57dB (Pad = 0dB); -infinity to +37dB (Pad = 20dB)
Max Input Level:	+25dBu (Gain at minimum 'on' position, 20dB pad on)
Controls:	2x Gain, 20dB Pad, LF Level, MF Freq & Level, HF Level, Mod Level, Reverb Level, Feedback Suppression On/Off/Mode
	1x Dual Mono/Stereo Link Mode, Acoustic Modeling Amount, On/Off
Indicators:	2x Signal Present/Clip, 2x Feedback Suppression On/Off/Mode, 1x Acoustic Modeling On/Off

StageSource L2t

Compact, 2-Way All-in-One PA with Studio-Quality Sound



Technical Specifications

Electrical – Rear Panel

Input Types:	Line-level XLR-1/4", balanced	Stereo RCA, unbalanced	L6 LINK™ XLR
Input Impedance:	100 kΩ balanced	20 kΩ balanced	N/A
Max Input Levels:	+20dBu	+16dBV	N/A
Onset of Limiting:	+6dBu input (Reference/P.A. Speaker Mode, Master Level control at center-detent) -6dBu input (Reference/P.A. Speaker Mode, Master Level control at maximum)		
Output Types:	Balanced Loop Thru XLR	Balanced Mix Out XLR	L6 LINK XLR
Output Impedances:	Source-dependent	680Ω balanced	N/A
Controls:	Feedback Suppression On/Off/Mode, Master Level, Speaker Mode		
Indicators:	Signal Present/Clip, Feedback Suppression On/Off/Mode, Limit, 6x Speaker Mode, L6 LINK Status		

Digital Signal Processing

Speaker Modes:	Reference/P.A., Playback, Floor Monitor, Keyboards, Acoustic Guitar, Electric Guitar
On-board Effects:	Reverb, Modulation, Feedback Suppression, Acoustic Modeling
Transducer Protection:	Excursion limiting, thermal limiting
Digital Networking:	L6 LINK intelligent speaker networking system
Sensors:	Speaker orientation, pole sensor, power amp temperature, power supply temperature

Power Amplification and Supply

Output Channel:	HF	LF
Power Amplifier Type:	Class AB	Class D
Peak Output Power ¹ :	175 watts	655 watts
Power Supply Voltage Range:	100 - 240 VAC, ± 10%, 50/60Hz , automatic voltage selection	
Power Consumption:	250 watts (1/8th power)	
Cooling:	Digitally controlled, variable-speed 50 mm fan	
Protection:	Output overcurrent, overtemperature, DC fault	

Mechanical

Enclosure:	15 mm enclosure, 18 mm baffle, multi-ply hardwood, textured black paint, bass reflex design
Floor Monitor Upward Angle:	60° using kickstands, 30° using handle
Suspension Points:	M10 x 1.5 threaded inserts, qty: 4
Pullback Point:	M10 x 1.5 threaded insert, qty: 1
Grille:	18-gauge perforated steel, black powder coat finish
Pole Cup:	35 mm pole cup with sensor
Dimensions (HxWxD):	23.75" (603 mm) x 12.25" (312 mm) x 12.25" (312 mm)
Weight:	39.1 lb (17.7 kg)

Accessory Part Numbers

Speaker Bag:	98-037-0002
Short Pole:	98-037-0003
Long Pole:	98-037-0004
Eyebolt Suspension Kit:	98-037-0005

¹ 1kHz sine wave input, 1% THD+N unweighted into the nominal load impedance, single channel driven, before the onset of limiting.

StageSource L2t

Compact, 2-Way All-in-One PA with Studio-Quality Sound



Technical Specifications

Mixer Control Panel

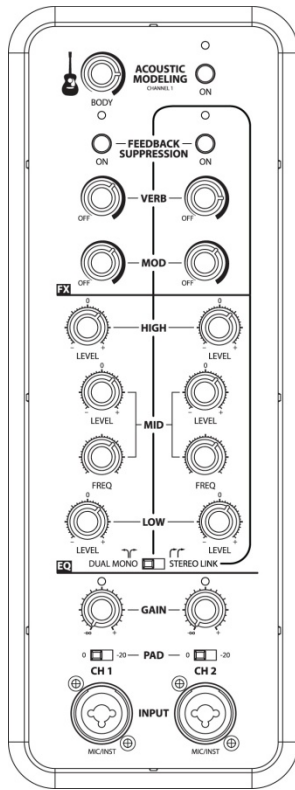

System Control Panel

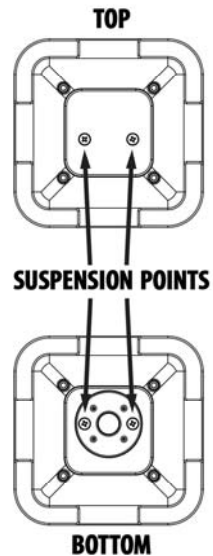
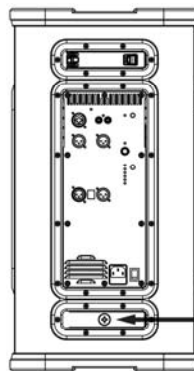
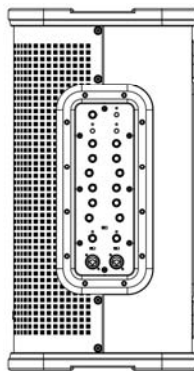
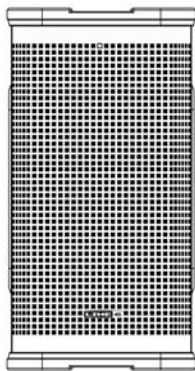
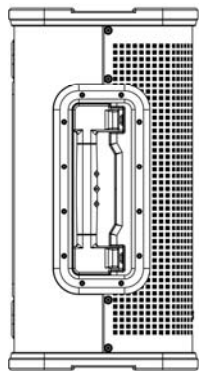
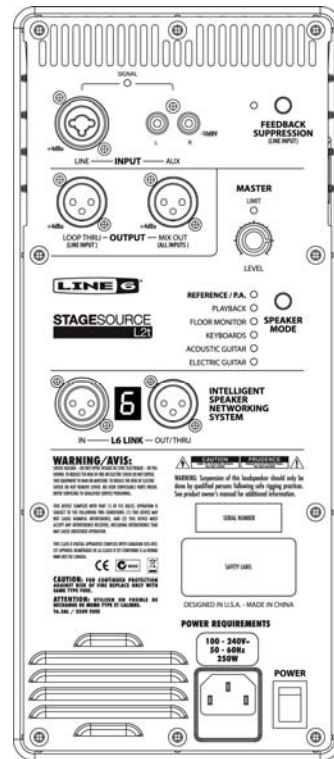

Height	23-3/4" / 603 mm
Width	12-1/4" / 312 mm
Depth	12-1/4" / 312 mm
Weight	39.1 lbs / 17.7 kg

StageSource L2t

Compact, 2-Way All-in-One PA with Studio-Quality Sound



Technical Specifications

Audio Signal Flow

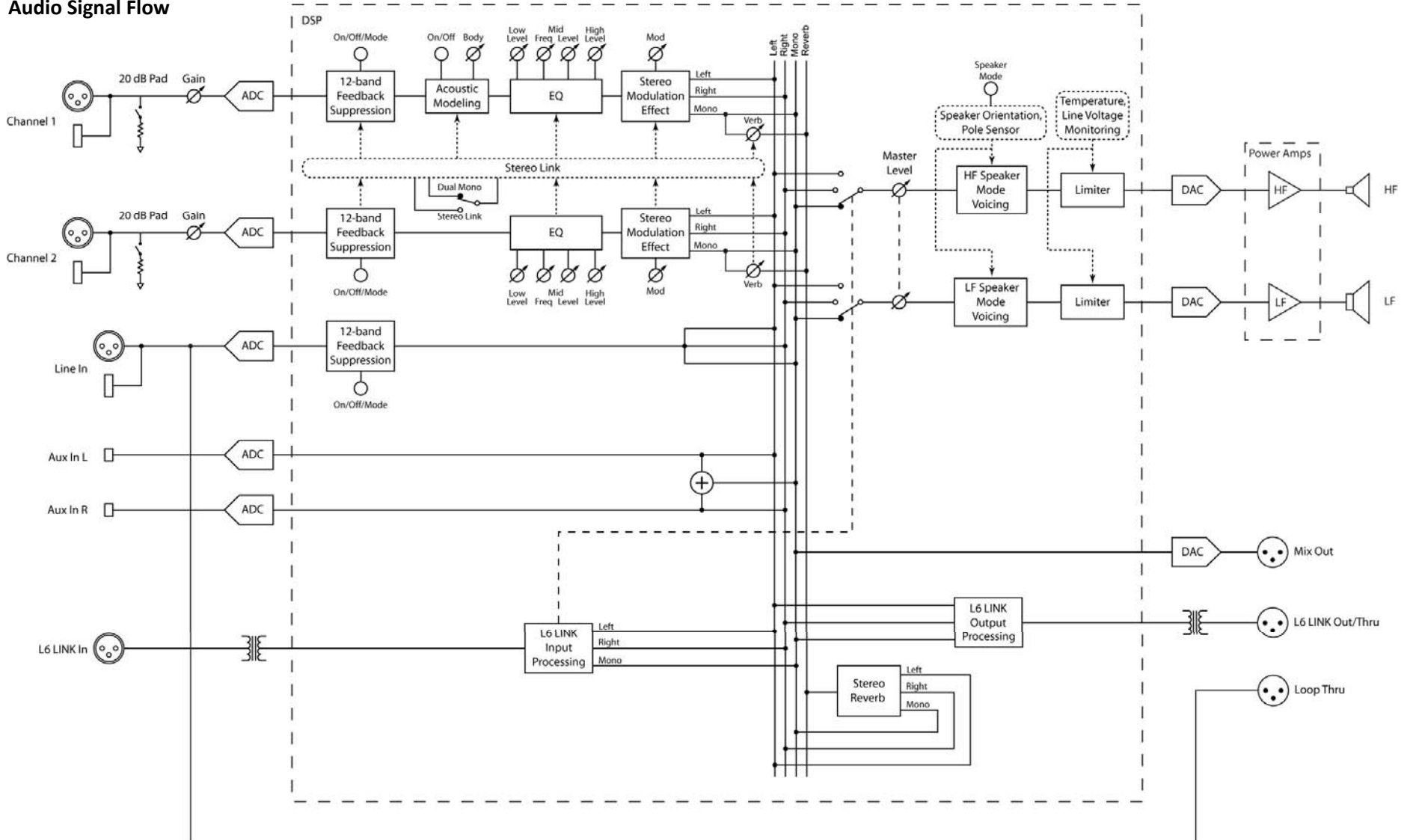

StageSource L2t

Compact, 2-Way All-in-One PA with Studio-Quality Sound



Technical Specifications

Note: All measurements taken in Reference/P.A. Speaker Mode.

Frequency Response

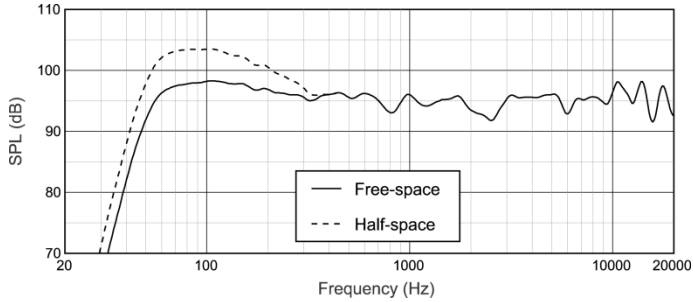

Beamwidth

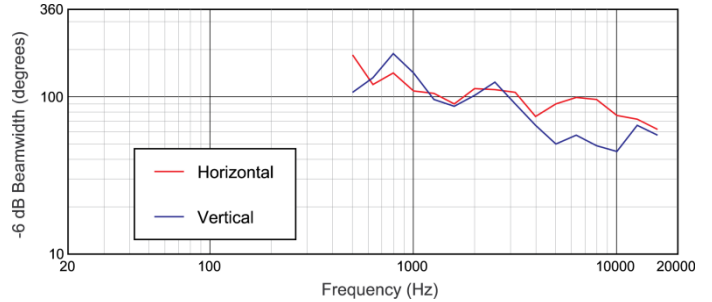

Directivity Index/Factor

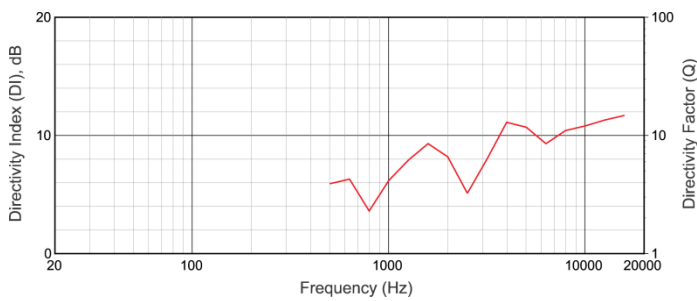

Off-axis, Horizontal

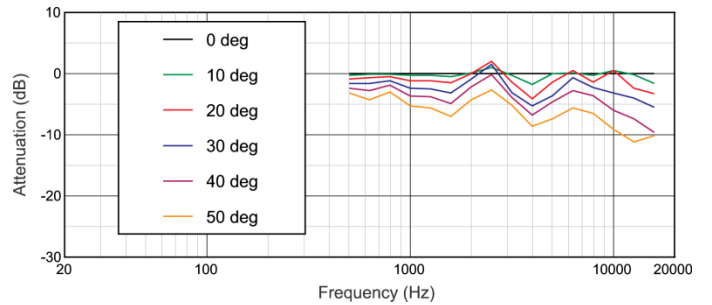

Off-axis, Vertical Down

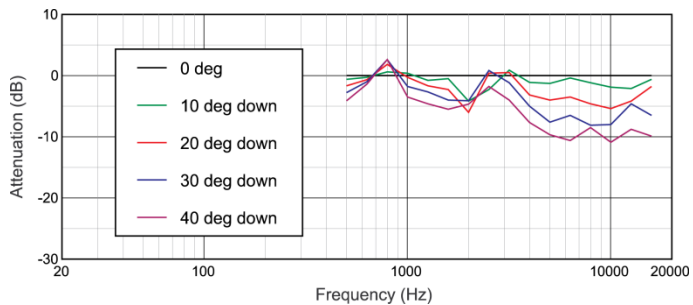

Off-axis, Vertical Up

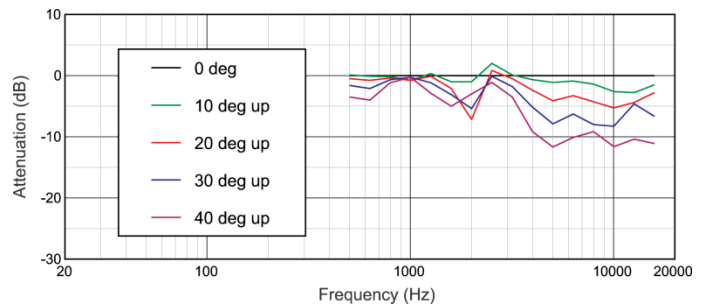

StageSource L2t

Compact, 2-Way All-in-One PA with Studio-Quality Sound



Technical Specifications

Horizontal Polar Response

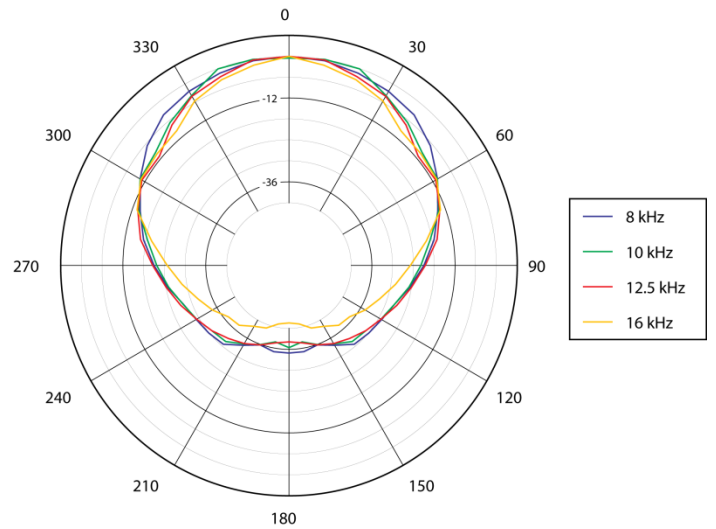
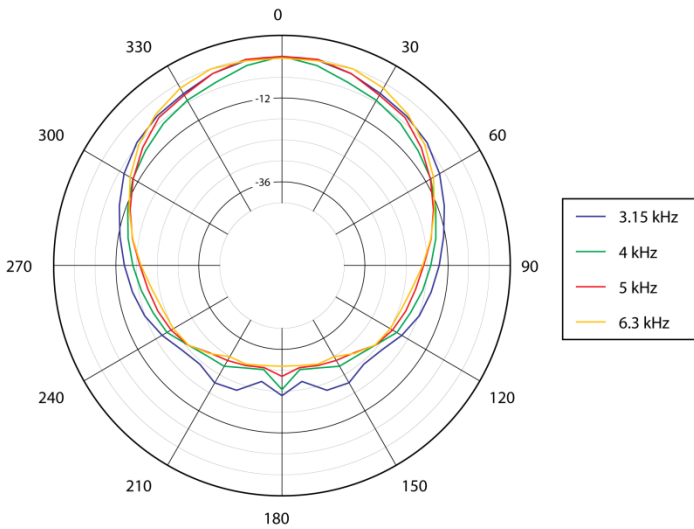
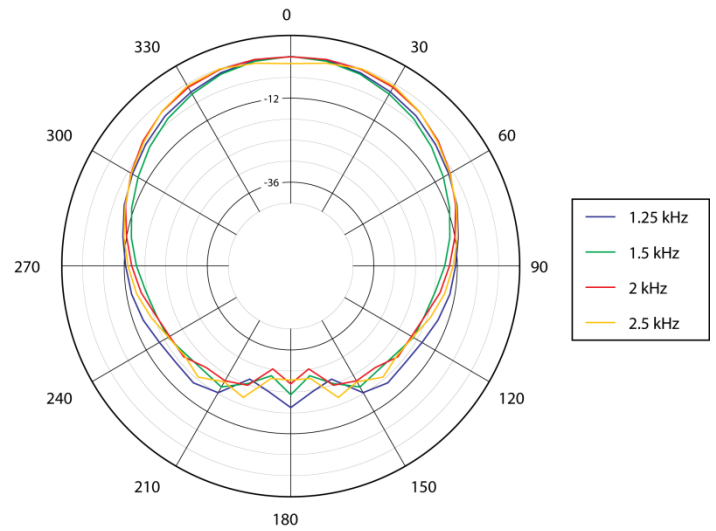
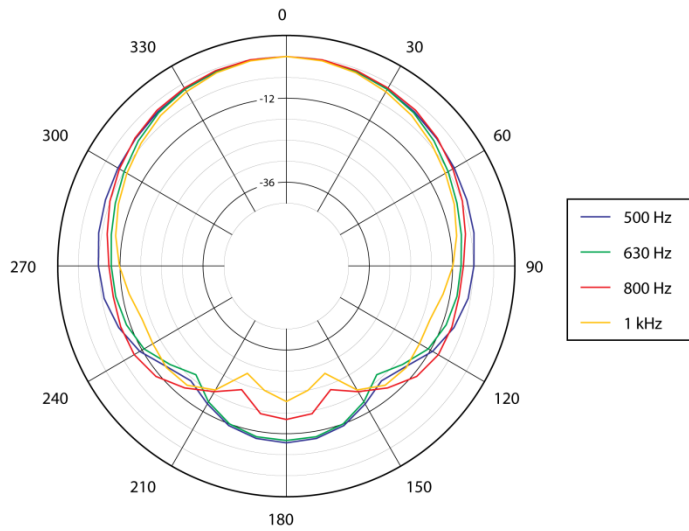

StageSource L2t

Compact, 2-Way All-in-One PA with Studio-Quality Sound



Technical Specifications

Vertical Polar Response

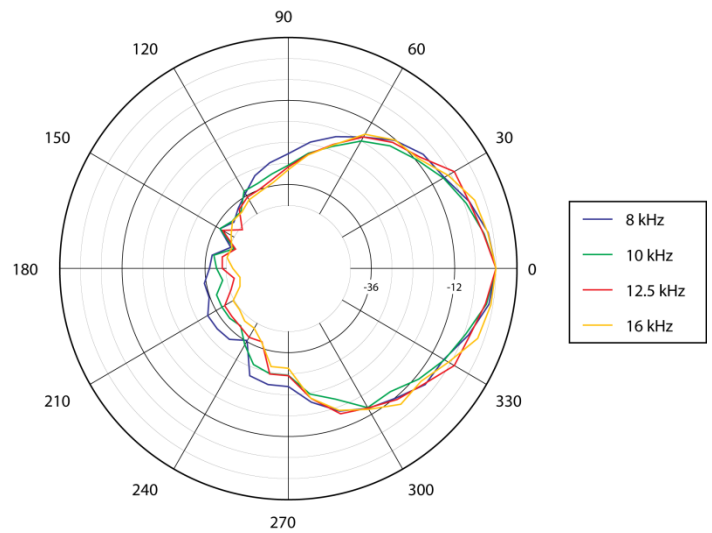
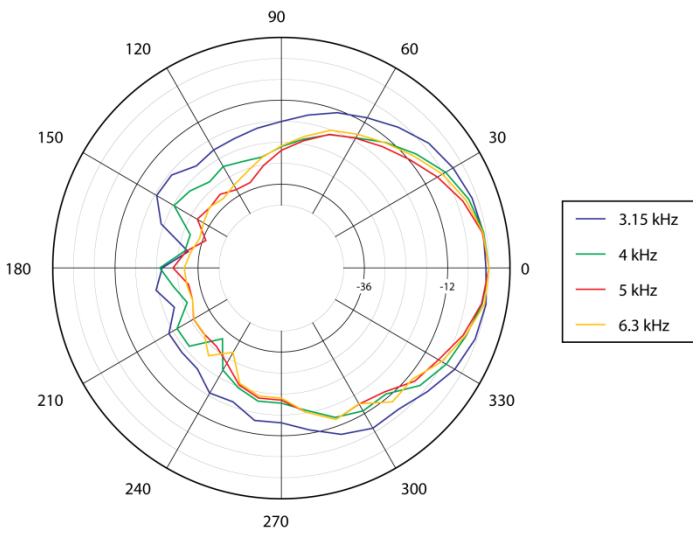
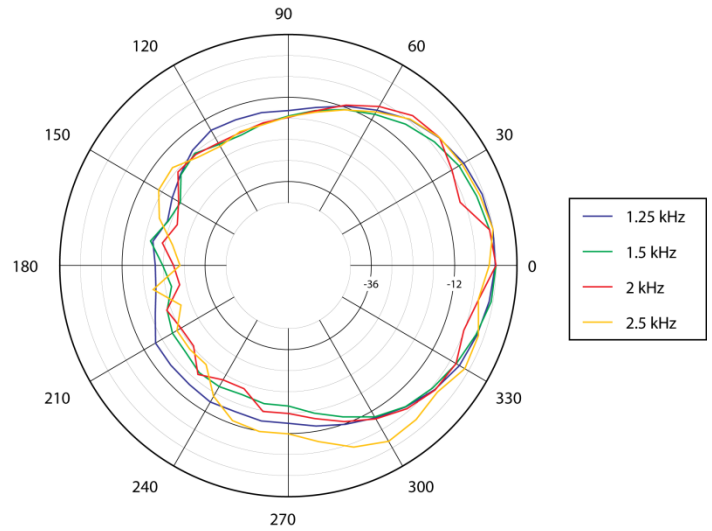
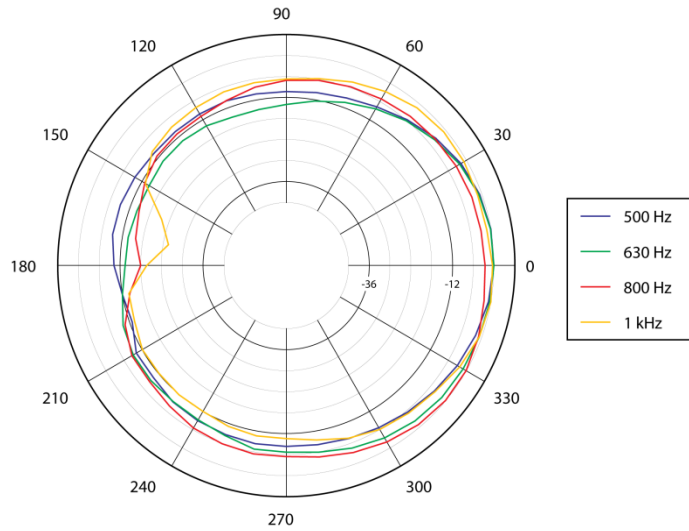

StageSource L2t

Compact, 2-Way All-in-One PA with Studio-Quality Sound



Technical Specifications

Personal PA

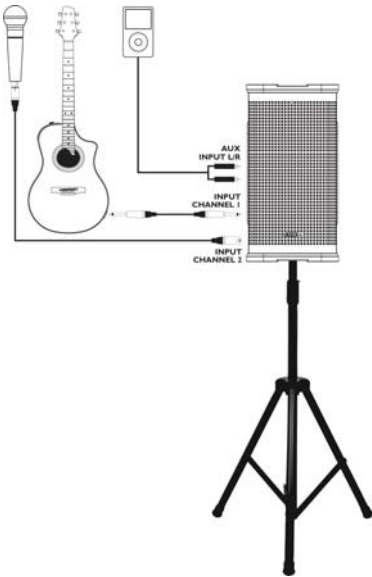

Duet PA

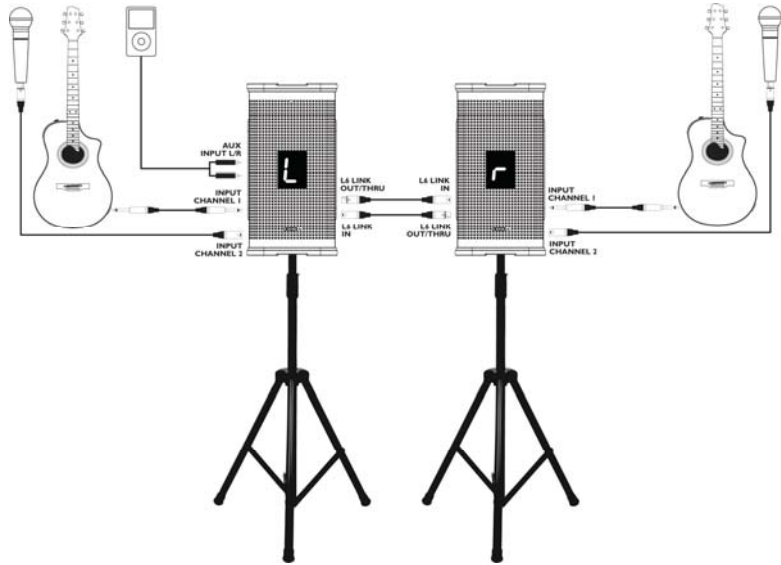

Small Club PA with Subs and Monitor

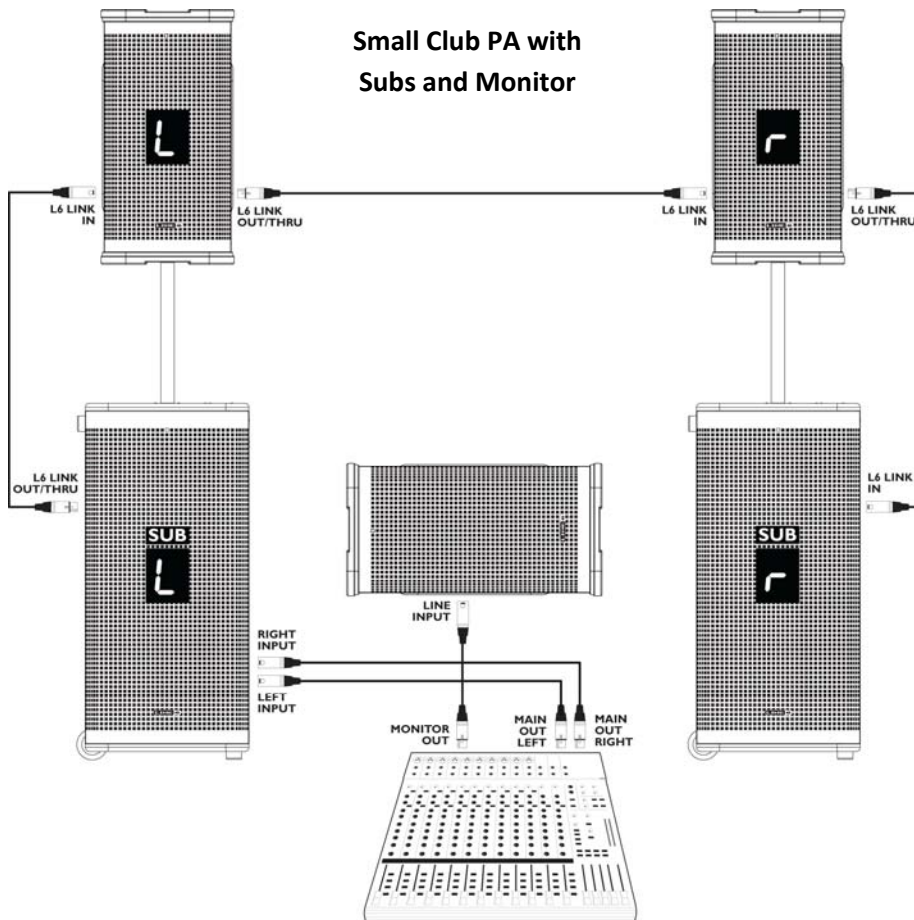

StageSource L2t

Compact, 2-Way All-in-One PA with Studio-Quality Sound



Technical Specifications

Small Club PA with StageScape M20d

